

Ezi-SPEED[®]

BLDC Motor Speed Control System



Fast, Accurate, Smooth Motion



Table of contents

1. Safety Pre-cautions	5
※ Before operation	5
※ Precautions	5
2. Characteristics.....	9
2.1 Part number.....	9
2.2 Combinations.....	10
2.3 Checking the parts	14
3. Specifications and dimensions of the drive	15
3.1 Specifications	15
3.2 Dimensions	18
4. Specifications and dimensions of the motor.....	19
4.1 Specifications	19
4.2 Dimensions	21
4.3 Characteristics of motor torque.....	23
5. Specifications and dimensions of the gearhead.....	25
5.1 Specifications of Motor with Gearbox 30W	25
5.2 Specifications of Motor with Hollow Shaft Gearbox	29
5.3 Dimensions of Motor with GearBox [mm].....	32
5.4 Dimensions of Motor with Hollow shaft GearBox [mm].....	36
6. Installing and wiring	38
6.1 Cautions on installations.....	38
6.2 External wiring diagram	40
6.3 Installing the combination parallel shaft gearhead	42
6.3.1 Installing the gearhead	42
6.3.2 Removing / changing the gearhead.....	43
6.3.3 Fixing method of load.....	43
6.3.4 Rotation direction of gearhead and transmission efficiency.....	44

6.3.5 Life time of Gearhead and Service factor	45
6.3.6 Maximum permissible torque of gearhead.....	45
6.3.7 Permissible overhung load and permissible thrust load.....	46
6.4 Installing the combination hollow shaft gearhead	47
6.4.1 Checking the parts.....	47
6.4.2 Cautions on operations.....	48
6.4.3 Mounting motor and gearhead.....	49
6.4.4 Installing	50
6.4.5 Rotation direction of gearhead and transmission efficiency.....	55
6.4.6 Maximum permissible torque of gearhead.....	55
6.4.7 Permissible overhung load and permissible thrust load.....	56
7. Setting and Operation.....	57
7.1 Exterior and names	57
7.2 Rotation direction switch.....	58
7.3 Connecting.....	60
7.3.1 Connection the power supply.....	60
7.3.2 Connecting the motor.....	61
7.3.3 Ground connection.....	62
7.3.4 Connecting the I/O signals	63
7.4 Operating.....	68
7.4.1 Connecting	68
7.4.2 Inputting the power	69
7.4.3 Operating.....	69
7.4.4 Reading of 7-Segment.....	70
7.5 Operating by I/O signals	71
7.5.1 Operating.....	71
7.5.2 Operating with multiple speeds.....	72

8. Convenient functions	77
8.1 Function list	77
8.2 Setting and 7-segments display.....	79
8.3 Parameter list.....	86
8.4 Display on the drive.....	89
8.5 Setting the operation data	92
8.6 Setting the acceleration time and deceleration time.....	93
8.7 Setting of torque limit	94
8.8 Lock of setting data	94
8.9 Limiting the setting range of the rotation speed.....	94
9.1 System diagram	96
10. Troubleshooting and remedial actions.....	98
10.1 Alarm.....	98
10.2 Warning	101
10.3 Troubleshooting and remedial actions	101
10.4 Regular inspection	104
11. Option (Sold separately).....	105
12. Reference	107
12.1 CE marking	107
12.2 Installing and wiring method in compliance EMC Directive	108

Manual version : [ver2.1]

Provided GUI version : N/A

1. Safety Pre-cautions

※ Before operation

- Thank you for your purchasing the FASTECH's Ezi-SPEED product.
- This manual describes handling, maintenance, repairing, diagnosis and troubleshooting of Ezi-SPEED.
- Before operating Ezi-SPEED, thoroughly read this manual for safety.
- After reading this manual, please keep this manual near Ezi-SPEED so that any user can read the manual whenever needed.



※ Precautions

• General Pre-cautions

- Contents of this manual are subjected to change without prior notice for functional improvement, change of specifications or user's better understanding. Thoroughly read the manual provided with the purchased Ezi-SPEED
- When the manual is damaged or lost, please contact with FASTECH's agents or our company at the address on the last page of the manual.
- Our company is not responsible for a product breakdown due to user's dismantling for the product, and such a breakdown is not guaranteed by the warranty.

• Safety Pre-cautions

- Before installation, operation and repairing the Ezi-SPEED, thoroughly read the manual and fully understand the contents, before operating the Ezi-SPEED please fully understand the mechanical characteristics of the product, related safety information and precautions.
- This manual divides safety precautions into **Attention** and **Warning**.



 Attention	If user does not properly handle the product, the user may seriously or slightly injured and damages may occur in the machine.
 Warning	If user does not properly handle the product, a dangerous situation (Such as an electric shock) may occur resulting in death or serious injuries.

- Although precaution is only a **Attention**, a serious result could be caused depending on the situation. Please follow safety precautions.

• **Checking the product**

 <p>Attention</p>	<p>Check if the product is damaged or parts are missing. Otherwise, the machine may get damaged or the user may get injured.</p> <p>Semiconductor device was used in Drive. Be careful handling. Static electricity will result in the drive damage. Motor and drive are sure to ground for prevent product damage from electric shock or static electricity.</p>
---	---

• **Installing**

 <p>Attention</p>	<p>Please carry the Ezi-SPEED carefully. Otherwise, the product may get damaged or user's foot may get injured by dropping the product.</p> <p>Use non-flammable materials such as metal in the place where the Ezi-SPEED is to be installed. Otherwise, a fire may occur.</p> <p>When installing several Ezi-SPEED in a sealed place, install a cooling fan to keep the ambient temperature of the product as 40°C or lower. Overheating may cause fire or other accidents.</p>
 <p>Warning</p>	<p>Installation, connection, operation, inspection and troubleshooting should be carried out by qualified personnel. Otherwise, a fire or other kinds of accidents may occur.</p>

• **Wiring**

 <p>Attention</p>	<p>Keep the rated range of input voltage for Ezi-SPEED drive. Otherwise, a fire or other kinds of accidents may occur.</p> <p>Cable connection should be following the wiring diagram. Otherwise, a fire or malfunction of machine may occur.</p> <p>Connecting the motor and drive</p>
---	--

	<p>Use a connection cable (Option) when extending the wiring distance the motor and drive.</p> <p>Prevent leakage current</p> <p>Stray capacitance exists between the drive's cable and other cables, the earth and the motor, respectively. A high-frequency current may leak out through such capacitance having a detrimental effect on the surrounding equipment. The actual leakage current depends on the drive's switching, the length of wiring between the drive and motor, and so on. When connecting and earth leakage breaker, use the products offering resistance against high frequency current.</p>
 <p>Warning</p>	<p>Before connecting cables, check if input power is off</p> <p>Otherwise, an electric shock or a fire may occur.</p> <p>The case of this Ezi-SPEED is installed from the ground of the internal circuit by the condenser. Please Ground the Ezi-SPEED.</p> <p>Otherwise, an electric shock or a fire may occur and a cause of malfunction of machine.</p>

• **Operating and setting change**

 <p>Attention</p>	<p>If a protection function (Alarm) occurs, firstly remove its cause and then release (Alarm reset) the protection function.</p> <p>If you operate continuously without removing its cause, the machine may get damaged or the user may get injured.</p> <p>Do not change free input to ON during motor operated</p> <p>Motor will be stop and holding power will be lost. The machine may get damaged or the user may get injured.</p> <p>Make all input signals to OFF before supply input voltage to Ezi-SPEED drive.</p> <p>The machine may get damaged or the user may get injured by motor operation.</p> <p>All parameter values are set by default factory setting value. Change this value after reading this manual thoroughly.</p> <p>Otherwise, the machine may get damaged or other kinds of accidents may occ</p>
---	---

	<p>ur.</p> <p>Cautions when using low temperature environment.</p> <p>When an ambient temperature is low, since the load torque may increase by oil seal or viscosity increment of grease used in the gearhead, the output torque may decrease or overload alarm may generate. However, as time passes, the oil seal or grease is warmed up, and the motor can be driven without generating and overload alarm.</p> <p>Noise elimination measures</p> <p>Provide noise elimination measures to prevent a motor or drive malfunction caused by external noise. For more effective elimination of noise, use a shielded I/O cable or attached ferrite core if a non-shielded cable is used.</p>
--	---

• **Repairing and checking**

 <p>Warning</p>	<p>Stop to supply power to the main circuit and wait sufficient time before checking or repairing this Ezi-SPEED</p> <p>Electricity remaining in the condenser may cause of electric shock. Do check and repair after a minute.</p> <p>Do not change cabling while power is being supplied.</p> <p>Otherwise, the user may get injured or the product and machine may get damaged.</p> <p>Do not reconstruct the Ezi-SPEED</p> <p>Otherwise, an electric shock may occur or the product and machine get damaged. And the reconstructed product cannot get after service.</p> <p>Conduct insulation resistance measurement or dielectric strength test separately on the motor and the drive.</p> <p>Conducting the insulation resistance measurement or dielectric strength test with the motor and drive connected may result in damage to the product.</p> <p>Grease prevent measures</p> <p>A small amount of grease may come out from the gearhead. If there is concern over possible environmental damage resulting from the leakage of grease, install an oil tray or similar prevention device. Oil leakage may lead to problem in customer's equipment or products.</p>
---	--

2. Characteristics

2.1 Part number

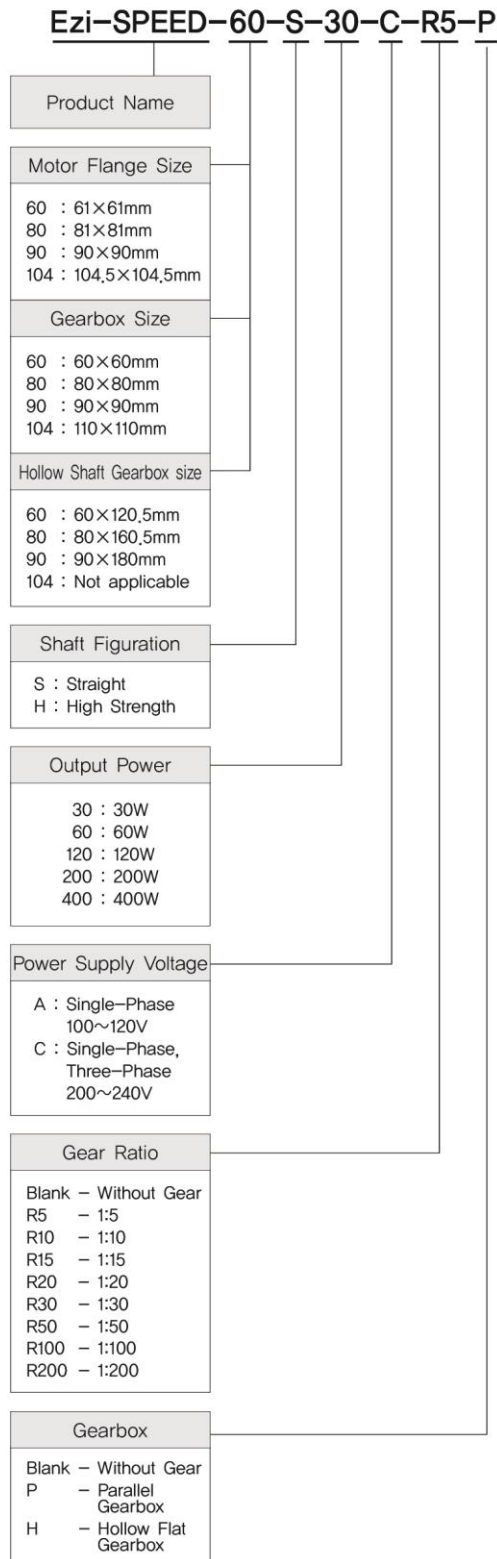

2.2 Combinations

Standard Motor and Drive Combinations

Unit Part Number	Motor Part Number	Drive Part Number
Ezi-SPEED-60-S-30-A	ESM-60-S-30	ESD-30-A
Ezi-SPEED-60-S-30-C		ESD-30-C
Ezi-SPEED-80-S-60-A	ESM-80-S-60	ESD-60-A
Ezi-SPEED-80-S-60-C		ESD-60-C
Ezi-SPEED-90-S-120-A	ESM-90-S-120	ESD-120-A
Ezi-SPEED-90-S-120-C		ESD-120-C
Ezi-SPEED-104-S-200-C	ESM-104-S-200	ESD-200-C
Ezi-SPEED-104-S-400-C	ESM-104-S-400	ESD-400-C

Gearhead Mounted Motor and Drive Combinations

Unit Part Number	Motor Part Number	Drive Part Number	Gearhead Part Number	감속 비
Ezi-SPEED-60-H-30-A-R5-P	ESM-60-H-30	ESD-30-A	ESG-60-H-R5-P	1:5
Ezi-SPEED-60-H-30-C-R5-P		ESD-30-C		
Ezi-SPEED-60-H-30-A-R5-H		ESD-30-A	ESG-60-H-R5-H	
Ezi-SPEED-60-H-30-C-R5-H		ESD-30-C		
Ezi-SPEED-60-H-30-A-R10-P		ESD-30-A	ESG-60-H-R10-P	1:10
Ezi-SPEED-60-H-30-C-R10-P		ESD-30-C		
Ezi-SPEED-60-H-30-A-R10-H		ESD-30-A	ESG-60-H-R10-H	
Ezi-SPEED-60-H-30-C-R10-H		ESD-30-C		
Ezi-SPEED-60-H-30-A-R15-P		ESD-30-A	ESG-60-H-R15-P	1:15
Ezi-SPEED-60-H-30-C-R15-P		ESD-30-C		
Ezi-SPEED-60-H-30-A-R15-H		ESD-30-A	ESG-60-H-R15-H	
Ezi-SPEED-60-H-30-C-R15-H		ESD-30-C		
Ezi-SPEED-60-H-30-A-R20-P		ESD-30-A	ESG-60-H-R20-P	1:20
Ezi-SPEED-60-H-30-C-R20-P		ESD-30-C		
Ezi-SPEED-60-H-30-A-R20-H		ESD-30-A	ESG-60-H-R20-H	
Ezi-SPEED-60-H-30-C-R20-H		ESD-30-C		
Ezi-SPEED-60-H-30-A-R30-P		ESD-30-A	ESG-60-H-R30-P	1:30
Ezi-SPEED-60-H-30-C-R30-P		ESD-30-C		
Ezi-SPEED-60-H-30-A-R30-H		ESD-30-A	ESG-60-H-R30-H	
Ezi-SPEED-60-H-30-C-R30-H		ESD-30-C		

Unit Part Number	Motor Part Number	Drive Part Number	Gearhead Part Number	감속 비
Ezi-SPEED-60-H-30-A-R50-P		ESD-30-A	ESG-60-H-R50-P	1:50
Ezi-SPEED-60-H-30-C-R50-P		ESD-30-C		
Ezi-SPEED-60-H-30-A-R50-H		ESD-30-A	ESG-60-H-R50-H	
Ezi-SPEED-60-H-30-C-R50-H		ESD-30-C		
Ezi-SPEED-60-H-30-A-R100-P		ESD-30-A	ESG-60-H-R100-P	1:100
Ezi-SPEED-60-H-30-C-R100-P		ESD-30-C		
Ezi-SPEED-60-H-30-A-R100-H		ESD-30-A	ESG-60-H-R100-H	
Ezi-SPEED-60-H-30-C-R100-H		ESD-30-C		
Ezi-SPEED-60-H-30-A-R200-P		ESD-30-A	ESG-60-H-R200-P	1:200
Ezi-SPEED-60-H-30-C-R200-P		ESD-30-C		
Ezi-SPEED-60-H-30-A-R200-H		ESD-30-A	ESG-60-H-R200-H	
Ezi-SPEED-60-H-30-C-R200-H		ESD-30-C		
Ezi-SPEED-80-H-60-A-R5-P	ESM-80-H-60	ESD-60-A	ESG-80-H-R5-P	1:5
Ezi-SPEED-80-H-60-C-R5-P		ESD-60-C		
Ezi-SPEED-80-H-60-A-R5-H		ESD-60-A	ESG-80-H-R5-H	
Ezi-SPEED-80-H-60-C-R5-H		ESD-60-C		
Ezi-SPEED-80-H-60-A-R10-P		ESD-60-A	ESG-80-H-R10-P	1:10
Ezi-SPEED-80-H-60-C-R10-P		ESD-60-C		
Ezi-SPEED-80-H-60-A-R10-H		ESD-60-A	ESG-80-H-R10-H	
Ezi-SPEED-80-H-60-C-R10-H		ESD-60-C		
Ezi-SPEED-80-H-60-A-R15-P		ESD-60-A	ESG-80-H-R15-P	1:15
Ezi-SPEED-80-H-60-C-R15-P		ESD-60-C		
Ezi-SPEED-80-H-60-A-R15-H		ESD-60-A	ESG-80-H-R15-H	
Ezi-SPEED-80-H-60-C-R15-H		ESD-60-C		
Ezi-SPEED-80-H-60-A-R20-P		ESD-60-A	ESG-80-H-R20-P	1:20
Ezi-SPEED-80-H-60-C-R20-P		ESD-60-C		
Ezi-SPEED-80-H-60-A-R20-H		ESD-60-A	ESG-80-H-R20-H	
Ezi-SPEED-80-H-60-C-R20-H		ESD-60-C		
Ezi-SPEED-80-H-60-A-R30-P		ESD-60-A	ESG-80-H-R30-P	1:30
Ezi-SPEED-80-H-60-C-R30-P		ESD-60-C		
Ezi-SPEED-80-H-60-A-R30-H		ESD-60-A	ESG-80-H-R30-H	
Ezi-SPEED-80-H-60-C-R30-H		ESD-60-C		
Ezi-SPEED-80-H-60-A-R50-P		ESD-60-A	ESG-80-H-R50-P	1:50
Ezi-SPEED-80-H-60-C-R50-P		ESD-60-C		
Ezi-SPEED-80-H-60-A-R50-H		ESD-60-A	ESG-80-H-R50-H	

Unit Part Number	Motor Part Number	Drive Part Number	Gearhead Part Number	감속 비
Ezi-SPEED-80-H-60-C-R50-H		ESD-60-C	ESG-80-H-R100-P	1:100
Ezi-SPEED-80-H-60-A-R100-P		ESD-60-A		
Ezi-SPEED-80-H-60-C-R100-P		ESD-60-C	ESG-80-H-R100-H	
Ezi-SPEED-80-H-60-A-R100-H		ESD-60-A		
Ezi-SPEED-80-H-60-C-R100-H		ESD-60-C	ESG-80-H-R200-P	
Ezi-SPEED-80-H-60-A-R200-P		ESD-60-A		
Ezi-SPEED-80-H-60-C-R200-P		ESD-60-C	ESG-80-H-R200-H	
Ezi-SPEED-80-H-60-A-R200-H		ESD-60-A		
Ezi-SPEED-80-H-60-C-R200-H		ESD-60-C	ESM-90-H-120	
Ezi-SPEED-90-H-120-A-R5-P	ESD-120-A	ESG-90-H-R5-P		1:5
Ezi-SPEED-90-H-120-C-R5-P	ESD-120-C			
Ezi-SPEED-90-H-120-A-R5-H	ESD-120-A	ESG-90-H-R5-H		
Ezi-SPEED-90-H-120-C-R5-H	ESD-120-C			
Ezi-SPEED-90-H-120-A-R10-P	ESD-120-A	ESG-90-H-R10-P		1:10
Ezi-SPEED-90-H-120-C-R10-P	ESD-120-C			
Ezi-SPEED-90-H-120-A-R10-H	ESD-120-A	ESG-90-H-R10-H		
Ezi-SPEED-90-H-120-C-R10-H	ESD-120-C			
Ezi-SPEED-90-H-120-A-R15-P	ESD-120-A	ESG-90-H-R15-P		1:15
Ezi-SPEED-90-H-120-C-R15-P	ESD-120-C			
Ezi-SPEED-90-H-120-A-R15-H	ESD-120-A	ESG-90-H-R15-H		
Ezi-SPEED-90-H-120-C-R15-H	ESD-120-C			
Ezi-SPEED-90-H-120-A-R20-P	ESD-120-A	ESG-90-H-R20-P		1:20
Ezi-SPEED-90-H-120-C-R20-P	ESD-120-C			
Ezi-SPEED-90-H-120-A-R20-H	ESD-120-A	ESG-90-H-R20-H		
Ezi-SPEED-90-H-120-C-R20-H	ESD-120-C			
Ezi-SPEED-90-H-120-A-R30-P	ESD-120-A	ESG-90-H-R30-P		1:30
Ezi-SPEED-90-H-120-C-R30-P	ESD-120-C			
Ezi-SPEED-90-H-120-A-R30-H	ESD-120-A	ESG-90-H-R30-H		
Ezi-SPEED-90-H-120-C-R30-H	ESD-120-C			
Ezi-SPEED-90-H-120-A-R50-P	ESD-120-A	ESG-90-H-R50-P		1:50
Ezi-SPEED-90-H-120-C-R50-P	ESD-120-C			
Ezi-SPEED-90-H-120-A-R50-H	ESD-120-A	ESG-90-H-R50-H		
Ezi-SPEED-90-H-120-C-R50-H	ESD-120-C			
Ezi-SPEED-90-H-120-A-R100-P	ESD-120-A	ESG-90-H-R100-P	1:100	
Ezi-SPEED-90-H-120-C-R100-P	ESD-120-C			

Unit Part Number	Motor Part Number	Drive Part Number	Gearhead Part Number	감속 비
Ezi-SPEED-90-H-120-A-R100-H		ESD-120-A	ESG-90-H-R100-H	1:200
Ezi-SPEED-90-H-120-C-R100-H		ESD-120-C		
Ezi-SPEED-90-H-120-A-R200-P		ESD-120-A	ESG-90-H-R200-P	
Ezi-SPEED-90-H-120-C-R200-P		ESD-120-C		
Ezi-SPEED-90-H-120-A-R200-H		ESD-120-A	ESG-90-H-R200-H	
Ezi-SPEED-90-H-120-C-R200-H		ESD-120-C		
Ezi-SPEED-104-H-200-C-R5-P	ESM-104-H-200	ESD-200-C	ESG-104-H-R5-P	1:5
Ezi-SPEED-104-H-200-C-R10-P			ESG-104-H-R10-P	1:10
Ezi-SPEED-104-H-200-C-R15-P			ESG-104-H-R15-P	1:15
Ezi-SPEED-104-H-200-C-R20-P			ESG-104-H-R20-P	1:20
Ezi-SPEED-104-H-200-C-R30-P			ESG-104-H-R30-P	1:30
Ezi-SPEED-104-H-200-C-R50-P			ESG-104-H-R50-P	1:50
Ezi-SPEED-104-H-200-C-R100-P			ESG-104-H-R100-P	1:100
Ezi-SPEED-104-H-200-C-R200-P			ESG-104-H-R200-P	1:200
Ezi-SPEED-104-H-400-C-R5-P	ESM-104-H-400	ESD-400-C	ESG-104-H-R5-P	1:5
Ezi-SPEED-104-H-400-C-R10-P			ESG-104-H-R10-P	1:10
Ezi-SPEED-104-H-400-C-R15-P			ESG-104-H-R15-P	1:15
Ezi-SPEED-104-H-400-C-R20-P			ESG-104-H-R20-P	1:20
Ezi-SPEED-104-H-400-C-R30-P			ESG-104-H-R30-P	1:30
Ezi-SPEED-104-H-400-C-R50-P			ESG-104-H-R50-P	1:50
Ezi-SPEED-104-H-400-C-R100-P			ESG-104-H-R100-P	1:100
Ezi-SPEED-104-H-400-C-R200-P			ESG-104-H-R200-P	1:200

2.3 Checking the parts

Verify that the items listed below are included. Report any missing or damaged items to sales office from which you purchased the parts.

Standard Motor and Drive Combinations

- Motor 1 EA
- Drive 1 EA
- Connection cable 1 EA
(Only models with a supplied connection cable)
- CN1 connector (5 pins) 1 EA
- CN4 connector (13 pins) 1 EA
- Earth screw 2 EA
- StartUp Guide 1 EA

Combination type Parallel Shaft Gearhead

- Parallel shaft gearhead 1 EA
- Hexagonal socket head bolt set 1 SET
(Bolt, Hexagon nut, Flat washer, Spring washer, 4 pcs each)
- Key 1 EA
- Parallel shaft gearhead operation manual 1 EA

Combination type Hollow Shaft Gearhead

- Hollow shaft gearhead..... 1 EA
- Hexagonal socket head bolt set..... 1 SET
(Bolt, Hexagon nut, Flat washer, Spring washer, 4 pcs each)
- Assembly bolts for motor and gearhead 4 EA
- Safety cover 1 EA
- Assembly screw of safety cover(M3)..... 2 EA
- Parallel key 1 EA
- Hollow shaft gearhead operation manual 1 EA

3. Specifications and dimensions of the drive

3.1 Specifications

Input Voltage 110V Specifications

Part Number		ESD-30-A	ESD-60-A	ESD-120-A
Rated Output Power(Continuous)		30W	60W	120W
Power supply Input	Rated Voltage	Single-Phase 100~120V		
	Frequency	50/60Hz		
	Permissible Frequency Range	±5%		
	Rated Input Current	0.95A	1.56A	2.69A
	Maximum input Current	2.85A	4.68A	8.07A
Rated Output Current		0.21A	0.36A	0.85A
Rated Torque		0.096N*m	0.192N*m	0.382N*m
Maximum Instantaneous Torque		0.288N*m	0.576N*m	1.146N*m
Rated Speed		3,000 [rpm]		
Speed Control Range		50~4,000 [rpm]		
Speed Regulation		0.2% or less / Conditions : 0~Rated Torque, Rated Speed, Rated Voltage, Normal Temperature		
I/O Signal	Input Signal Function	5 User Inputs (Photocoupler)		
	Output Signal Function	3 User Outputs (Photocoupler)		

Input Voltage 220V Specifications

Part Number		ESD-30-C	ESD-60-C	ESD-120-C	ESD-200-C	ESD-400-C
Rated Output Power(Continuous)		30W	60W	120W	200W	400W
Power supply Input	Rated Voltage	Single-Phase 200~240V / Three-Phase 200~240V				
	Frequency	50/60Hz				
	Permissible Frequency Range	±5%				
	Rated Input Current	단상 : 0.55A 삼상 : 0.32A	단상 : 0.92A 삼상 : 0.53A	단상 : 1.61A 삼상 : 0.93A	단상 : 2.34A 삼상 : 1.35A	단상 : 3.88A 삼상 : 2.24A
	Maximum input Current	단상 : 1.65A 삼상 : 0.95A	단상 : 2.76A 삼상 : 1.59A	단상 : 4.83A 삼상 : 2.79A	단상 : 7.02A 삼상 : 4.05A	단상 : 11.6A 삼상 : 6.72A
Rated Output Current		0.21A	0.36A	0.85A	1.65A	2.37A
Rated Torque		0.096N*m	0.192N*m	0.382N*m	0.637N*m	1.272N*m
Maximum Instantaneous Torque		0.288N*m	0.576N*m	1.146N*m	1.911N*m	3.816N*m
Rated Speed		3,000 [rpm]				
Speed Control Range		50~4,000 [rpm]				
Speed Regulation		0.2% or less / Conditions : 0~Rated Torque, Rated Speed, Rated Voltage, Normal Temperature				
I/O Signal	Input Signal Function	5 User Inputs (Photocoupler)				
	Output Signal Function	3 User Outputs (Photocoupler)				

General specification

Operation Environment	Temperature	0~40°C (Non-freezing)
	Humidity	35~85% (Non-condensing)
	Elevation	Elevation of 1000m(3300ft) or less
	Environment	No corrosive gas and dust No used at special environment like a radioactive material, magnetic field and a vacuum state, etc
	Vibration resistance	0.5g
Storage Environment	Temperature	Motor : -20~70°C (Non-freezing) Drive : -25~70°C (Non-freezing)
	Humidity	35~85% (Non-condensing)
	Elevation	Elevation of 3000m(10000ft) or less
	Environment	No corrosive gas and dust, No splashing water and oil No used at special environment like a radioactive material, magnetic field and a vacuum state, etc
Transportation Environment	Temperature	Motor : -20~70°C (Non-freezing) Drive : -25~70°C (Non-freezing)
	Humidity	35~85% (Non-condensing)
	Elevation	Elevation of 10000m(33000ft) or less
	Environment	No corrosive gas and dust, No splashing water and oil No used at special environment like a radioactive material, magnetic field and a vacuum state, etc

3.2 Dimensions

30W, 60W, 120W Drive

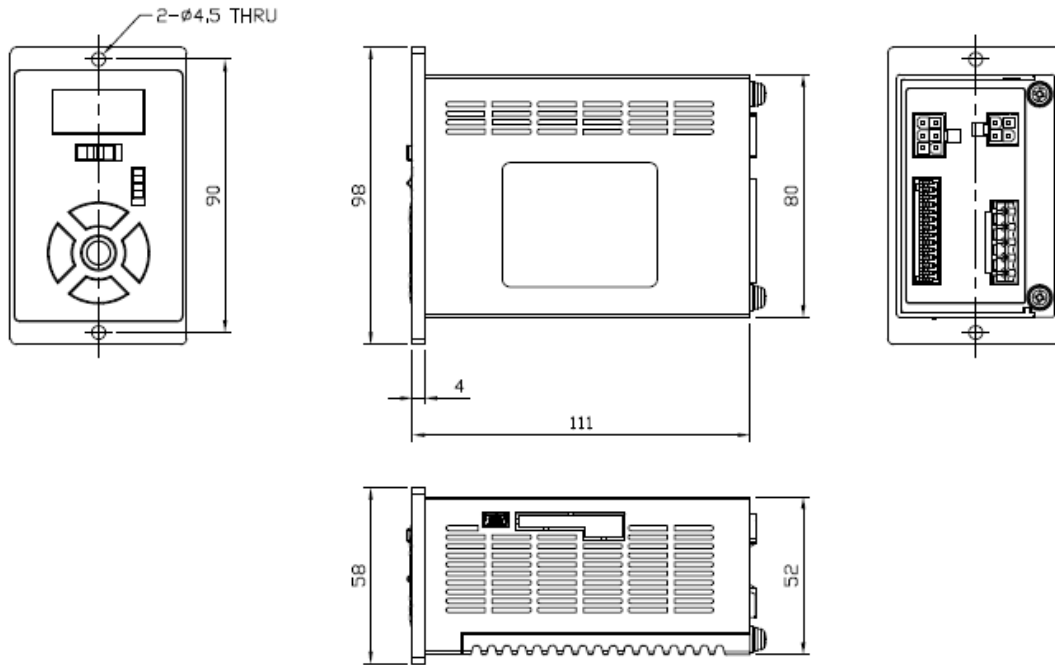

200W, 400W Drive

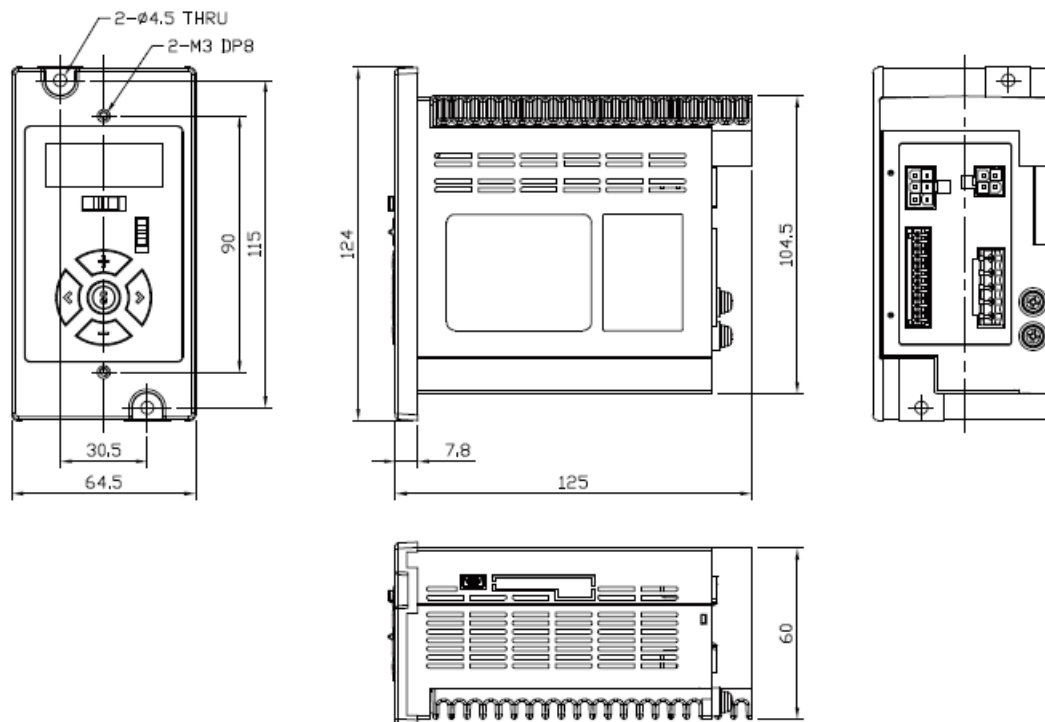

4. Specifications and dimensions of the motor

4.1 Specifications

Specifications

Item	Unit	ESM-60-S-30	ESM-80-S-60	ESM-90-S-120	ESM-104-S-200	ESM-104-S-400
Rated Output Power(Continuous)	W	30	60	120	200	400
Rated Torque	N·m	0.096	0.192	0.382	0.637	1.272
Rated Output Current	A	0.21	0.36	0.85	1.65	2.37
Rated Speed	rpm	3000				
Permissible Load Inertia Moment	$10^{-4}\text{Kg}\cdot\text{m}^2$	0.5	1.8	5.8	5.8	8.75
Inertia Moment	$10^{-4}\text{Kg}\cdot\text{m}^2$	0.086	0.234	0.61	0.61	0.66
BeakEMF(Phase)	mV/min	22.2	24.8	19	30	23
Torque Constant	N·m/Arms	0.074	0.071	0.076	0.068	0.122
Weight	Kg	0.5	0.8	1.3	2.4	2.4
Length	mm	62	74	94	156	156
Number of pole pairs	Pole pairs	5				
Permissible Overhung Load	10mm from Shaft : [N]	70	120	160	160	160
	20mm from Shaft : [N]	100	140	170	170	170
Promissible Thrust Load	N	Please don't thrust load. An unavoidable situation, please keep thrust load less than 50% of motor weight.				

General specifications

Item		Motor
Insulation Resistance		100MΩ or more when DC500V Mega tester is applied between coil and case after continuous operation under normal temperature and humidity.
Dielectric Strength		Sufficient to withstand when 1500VAC, 60Hz applied between coil and case for 1 minute after continuous operation under normal temperature and humidity.
Temperature Rise		The temperature rise of the coil is 60°C max. and that of the case surface is 50°C max. measured by thermocouple after rated continuous operation under normal temperature and humidity.
Operation Environment	Temperature	0 ~ +40°C
	Humidity	85% or less
	Environment	No corrosive gas and dust
Storage Environment	Temperature	-20 ~ +70°C
	Humidity	85% or less

4.2 Dimensions

ESM-60-S-30

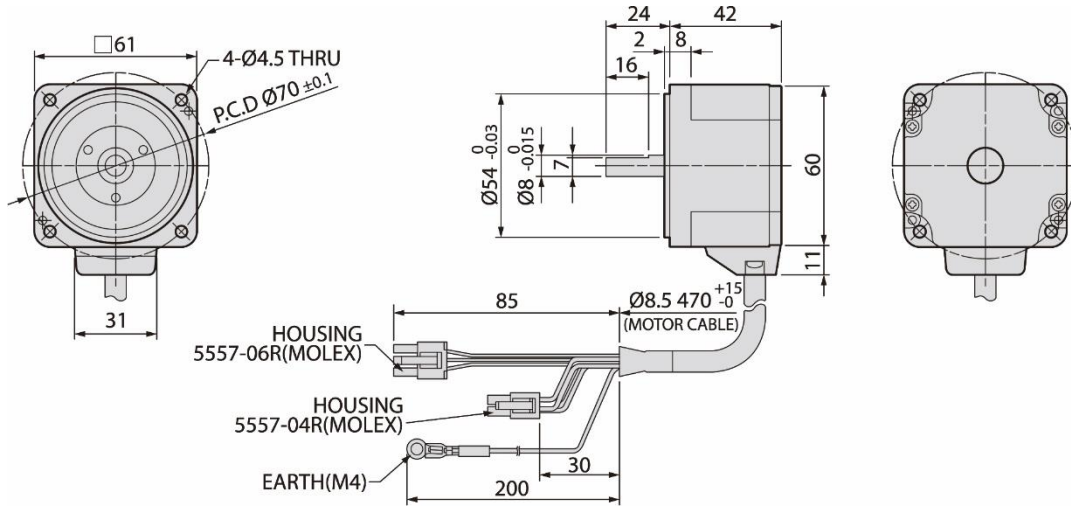

ESM-80-S-60

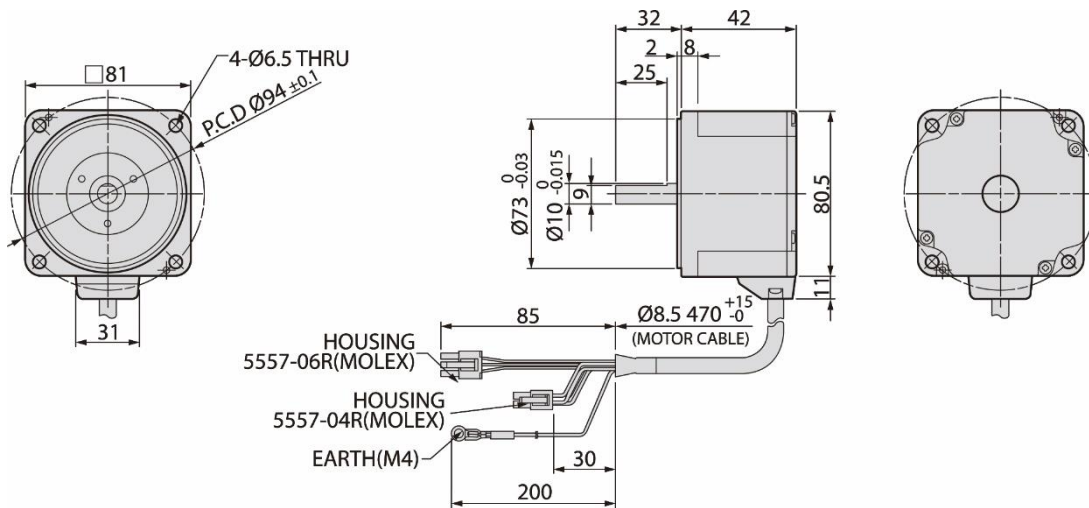

ESM-90-S-120

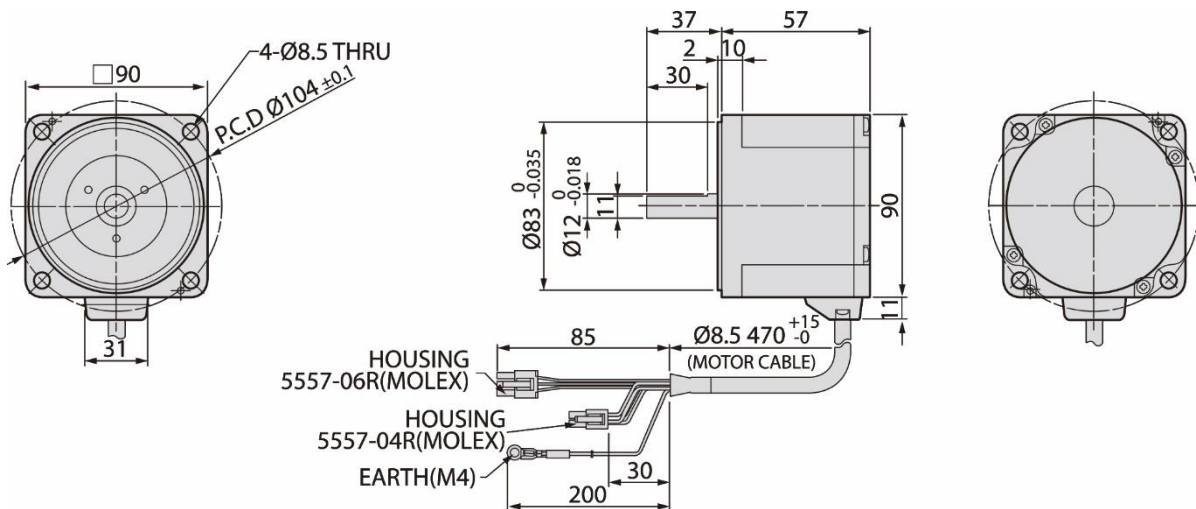

ESM-104-S-200

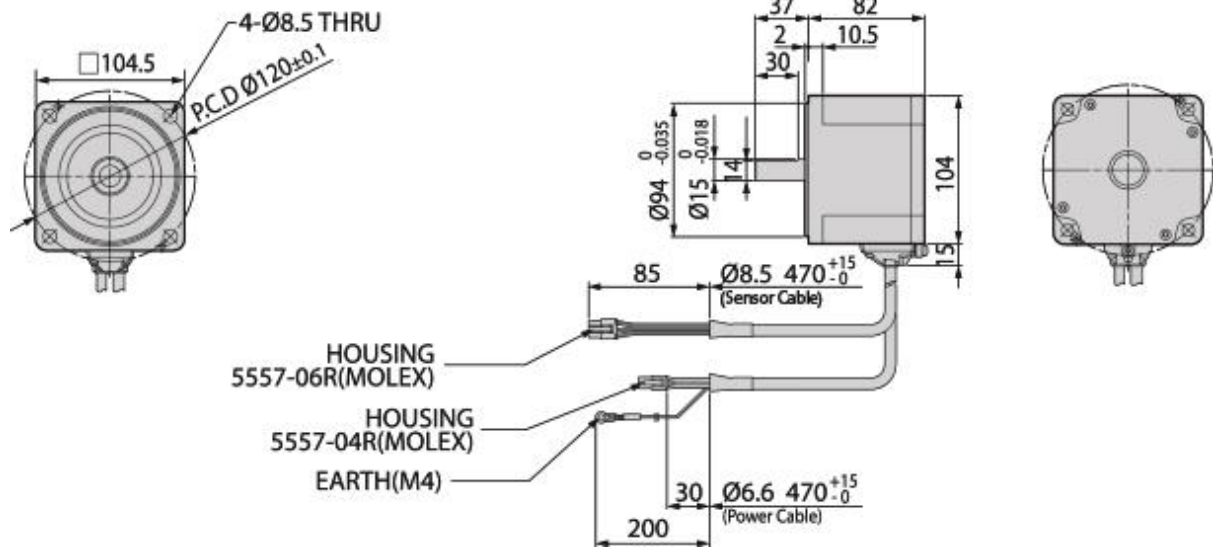

ESM-104-S-400

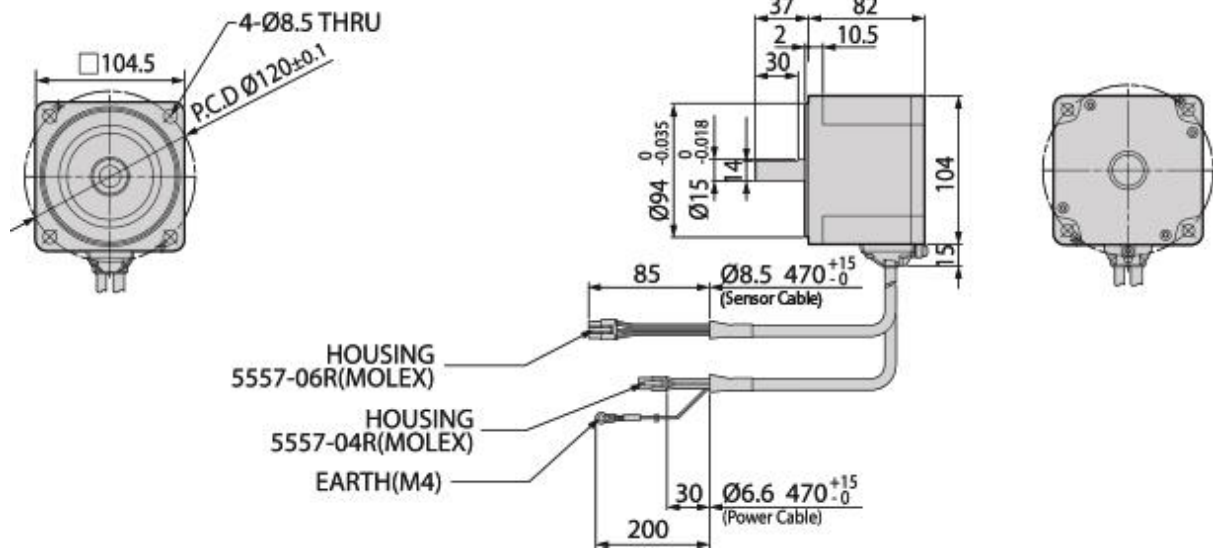

4.3 Characteristics of motor torque

30W

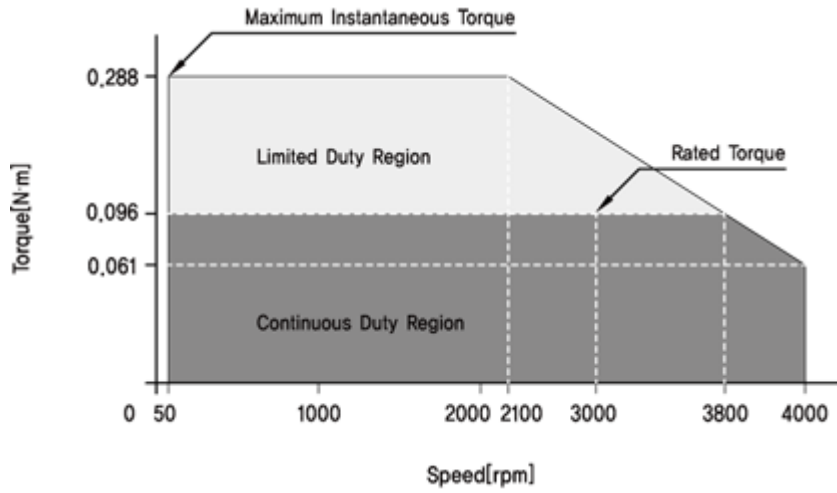

60W

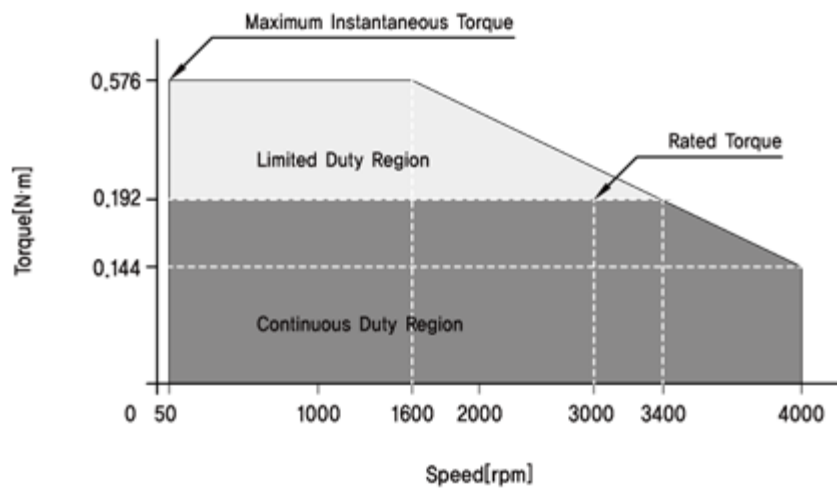

120W

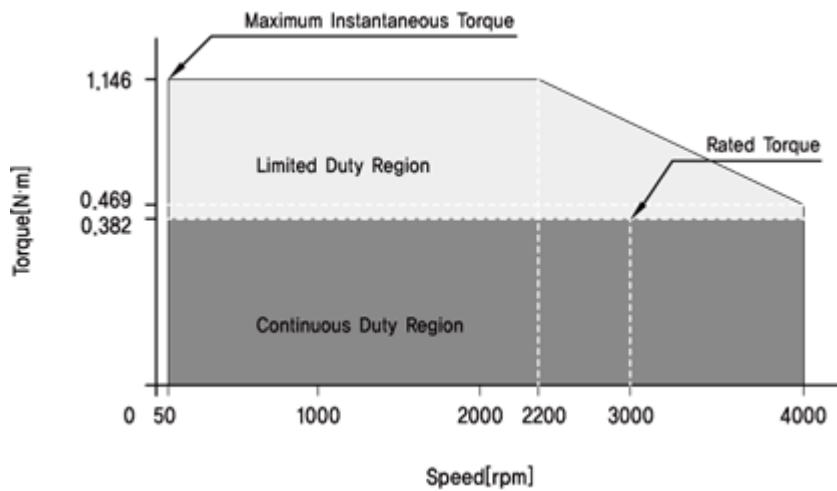

200W

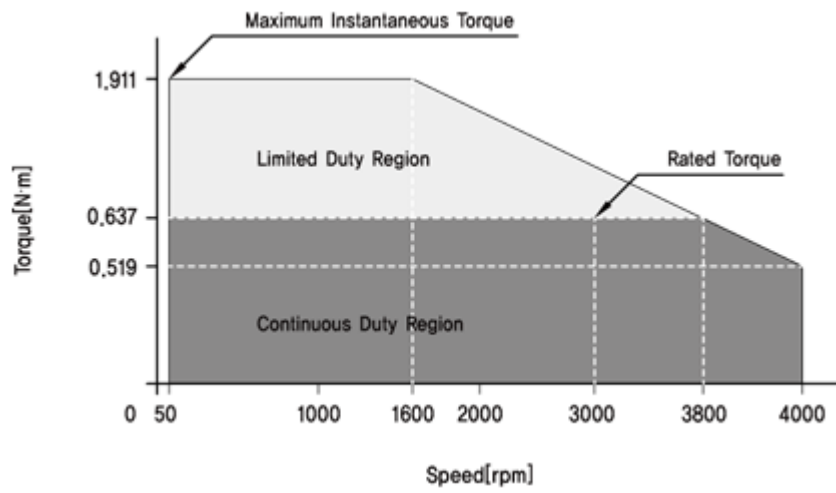

400W

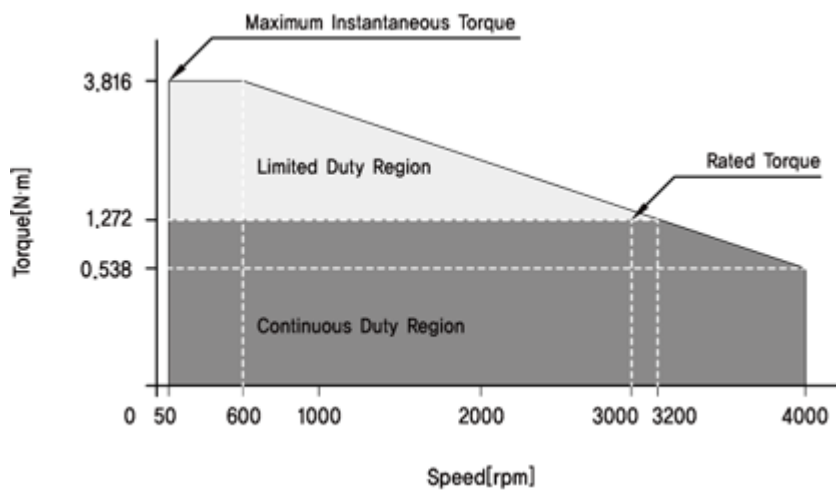

5. Specifications and dimensions of the gearhead

5.1 Specifications of Motor with Gearbox

30W

Unit Part Number	Gear Ratio	Permitted Torque [N·m]		Permitted Speed Range [rpm]	Unit Weight [kg]	Permitted Overhung Load [N]		Permitted Thrust Load [N]
		50~3,000 [rpm]	4,000 [rpm]			10mm from shaft end	20mm from shaft end	
Ezi-SPEED-60-H-30-A-R5-P	5	0.45	0.34	10~800	0.9	100	150	40
Ezi-SPEED-60-H-30-C-R5-P								
Ezi-SPEED-60-H-30-A-R10-P	10	0.9	0.68	5~400		150	200	
Ezi-SPEED-60-H-30-C-R10-P								
Ezi-SPEED-60-H-30-A-R15-P	15	1.35	1	3.3~266.7		150	200	
Ezi-SPEED-60-H-30-C-R15-P								
Ezi-SPEED-60-H-30-A-R20-P	20	1.8	1.4	2.5~200		150	200	
Ezi-SPEED-60-H-30-C-R20-P								
Ezi-SPEED-60-H-30-A-R30-P	30	2.6	1.9	1.7~133.3		200	300	
Ezi-SPEED-60-H-30-C-R30-P								
Ezi-SPEED-60-H-30-A-R50-P	50	4.3	3.2	1~80		200	300	
Ezi-SPEED-60-H-30-C-R50-P								
Ezi-SPEED-60-H-30-A-R100-P	100	6	5.4	0.5~40		200	300	
Ezi-SPEED-60-H-30-C-R100-P								
Ezi-SPEED-60-H-30-A-R200-P	200	6	5.4	0.25~20		200	300	
Ezi-SPEED-60-H-30-C-R200-P								

60W

Unit Part Number	Gear Ratio	Permitted Torque [N·m]		Permitted Speed Range [rpm]	Unit Weight [kg]	Permitted Overhung Load [N]		Permitted Thrust Load [N]
		50~3,000 [rpm]	4,000 [rpm]			10mm from shaft end	20mm from shaft end	
Ezi-SPEED-80-H-60-A-R5-P	5	0.9	0.68	10~800	1.6	200	250	100
Ezi-SPEED-80-H-60-C-R5-P								
Ezi-SPEED-80-H-60-A-R10-P	10	1.8	1.4	5~400		300	350	
Ezi-SPEED-80-H-60-C-R10-P								
Ezi-SPEED-80-H-60-A-R15-P	15	2.7	2	3.3~266.7		300	350	
Ezi-SPEED-80-H-60-C-R15-P								
Ezi-SPEED-80-H-60-A-R20-P	20	3.6	2.7	2.5~200		300	350	
Ezi-SPEED-80-H-60-C-R20-P								
Ezi-SPEED-80-H-60-A-R30-P	30	5.2	3.9	1.7~133.3		150	550	
Ezi-SPEED-80-H-60-C-R30-P								
Ezi-SPEED-80-H-60-A-R50-P	50	8.6	6.5	1~80		150	550	
Ezi-SPEED-80-H-60-C-R50-P								
Ezi-SPEED-80-H-60-A-R100-P	100	16	12.9	0.5~40	150	550		
Ezi-SPEED-80-H-60-C-R100-P								
Ezi-SPEED-80-H-60-A-R200-P	200	16	14	0.25~20	150	550		
Ezi-SPEED-80-H-60-C-R200-P								

120W

Unit Part Number	Gear Ratio	Permitted Torque [N·m]		Permitted Speed Range [rpm]	Unit Weight [kg]	Permitted Overhung Load [N]		Permitted Thrust Load [N]
		50~3,000 [rpm]	4,000 [rpm]			10mm from shaft end	20mm from shaft end	
Ezi-SPEED-90-H-120-A-R5-P	5	1.8	1.4	10~800	2.7	300	400	150
Ezi-SPEED-90-H-120-C-R5-P								
Ezi-SPEED-90-H-120-A-R10-P	10	3.6	2.7	5~400		400	500	
Ezi-SPEED-90-H-120-C-R10-P								
Ezi-SPEED-90-H-120-A-R15-P	15	5.4	4.1	3.3~266.7		400	500	
Ezi-SPEED-90-H-120-C-R15-P								
Ezi-SPEED-90-H-120-A-R20-P	20	7.2	5.4	2.5~200		400	500	
Ezi-SPEED-90-H-120-C-R20-P								
Ezi-SPEED-90-H-120-A-R30-P	30	10.3	7.7	1.7~133.3		400	500	
Ezi-SPEED-90-H-120-C-R30-P								
Ezi-SPEED-90-H-120-A-R50-P	50	17.2	12.9	1~80		400	500	
Ezi-SPEED-90-H-120-C-R50-P								
Ezi-SPEED-90-H-120-A-R100-P	100	30	25.8	0.5~40	400	500		
Ezi-SPEED-90-H-120-C-R100-P								
Ezi-SPEED-90-H-120-A-R200-P	200	30	27	0.25~20	400	500		
Ezi-SPEED-90-H-120-C-R200-P								

200W

Unit Part Number	Gear Ratio	Permitted Torque [N·m]		Permitted Speed Range [rpm]	Unit Weight [kg]	Permitted Overhung Load [N]		Permitted Thrust Load [N]
		50~3,000 [rpm]	4,000 [rpm]			10mm from shaft end	20mm from shaft end	
Ezi-SPEED-104-H-200-C-R5-P	5	2.9	2	10~800	4.2	300	400	150
Ezi-SPEED-104-H-200-C-R10-P	10	5.9	4.1	5~400		400	500	
Ezi-SPEED-104-H-200-C-R15-P	15	8.8	6.1	3.3~266.7				
Ezi-SPEED-104-H-200-C-R20-P	20	11.7	8.1	2.5~200		500	650	
Ezi-SPEED-104-H-200-C-R30-P	30	16.8	11.6	1.7~133.3				
Ezi-SPEED-104-H-200-C-R50-P	50	28	19.4	1~80				
Ezi-SPEED-104-H-200-C-R100-P	100	52.7	36.5	0.5~40				
Ezi-SPEED-104-H-200-C-R200-P	200	70	63	0.25~20				

400W

Unit Part Number	Gear Ratio	Permitted Torque [N·m]		Permitted Speed Range [rpm]	Unit Weight [kg]	Permitted Overhung Load [N]		Permitted Thrust Load [N]
		50~3,000 [rpm]	4,000 [rpm]			10mm from shaft end	20mm from shaft end	
Ezi-SPEED-104-H-400-C-R5-P	5	5.9	4.3	10~800	4.2	300	400	150
Ezi-SPEED-104-H-400-C-R10-P	10	11.7	8.6	5~400		400	500	
Ezi-SPEED-104-H-400-C-R15-P	15	17.6	12.8	3.3~266.7				
Ezi-SPEED-104-H-400-C-R20-P	20	23.4	17.1	2.5~200		500	650	
Ezi-SPEED-104-H-400-C-R30-P	30	33.5	24.5	1.7~133.3				
Ezi-SPEED-104-H-400-C-R50-P	50	55.9	40.9	1~80				
Ezi-SPEED-104-H-400-C-R100-P	100	70	63	0.5~40				
Ezi-SPEED-104-H-400-C-R200-P	200	70	63	0.25~20				

5.2 Specifications of Motor with Hollow Shaft Gearbox

30W

Unit Part Number	Gear Ratio	Permitted Torque [N·m]		Permitted Speed Range [rpm]	Unit Weight [kg]	Permitted Overhung Load [N]		Permitted Thrust Load [N]
		50~3,000 [rpm]	4,000 [rpm]			10mm from shaft end	20mm from shaft end	
Ezi-SPEED-60-H-30-A-R5-H	5	0.4	0.3	10~800	1.2	450	370	200
Ezi-SPEED-60-H-30-C-R5-H								
Ezi-SPEED-60-H-30-A-R10-H	10	0.85	0.64	5~400		500	400	
Ezi-SPEED-60-H-30-C-R10-H								
Ezi-SPEED-60-H-30-A-R15-H	15	1.3	0.96	3.3~266.7				
Ezi-SPEED-60-H-30-C-R15-H								
Ezi-SPEED-60-H-30-A-R20-H	20	1.7	1.3	2.5~200				
Ezi-SPEED-60-H-30-C-R20-H								
Ezi-SPEED-60-H-30-A-R30-H	30	2.6	1.9	1.7~133.3				
Ezi-SPEED-60-H-30-C-R30-H								
Ezi-SPEED-60-H-30-A-R50-H	50	4.3	3.2	1~80				
Ezi-SPEED-60-H-30-C-R50-H								
Ezi-SPEED-60-H-30-A-R100-H	100	8.5	6.4	0.5~40				
Ezi-SPEED-60-H-30-C-R100-H								
Ezi-SPEED-60-H-30-A-R200-H	200	17	12.8	0.25~20				
Ezi-SPEED-60-H-30-C-R200-H								

60W

Unit Part Number	Gear Ratio	Permitted Torque [N·m]		Permitted Speed Range [rpm]	Unit Weight [kg]	Permitted Overhung Load [N]		Permitted Thrust Load [N]
		50~3,000 [rpm]	4,000 [rpm]			10mm from shaft end	20mm from shaft end	
Ezi-SPEED-80-H-60-A-R5-H	5	0.85	0.64	10~800	2.2	800	660	400
Ezi-SPEED-80-H-60-C-R5-H								
Ezi-SPEED-80-H-60-A-R10-H	10	1.78	1.3	5~400		1,200	1,000	
Ezi-SPEED-80-H-60-C-R10-H								
Ezi-SPEED-80-H-60-A-R15-H	15	2.6	1.9	3.3~266.7				
Ezi-SPEED-80-H-60-C-R15-H								
Ezi-SPEED-80-H-60-A-R20-H	20	3.4	2.6	2.5~200				
Ezi-SPEED-80-H-60-C-R20-H								
Ezi-SPEED-80-H-60-A-R30-H	30	5.1	3.8	1.7~133.3				
Ezi-SPEED-80-H-60-C-R30-H								
Ezi-SPEED-80-H-60-A-R50-H	50	8.5	6.4	1~80				
Ezi-SPEED-80-H-60-C-R50-H								
Ezi-SPEED-80-H-60-A-R100-H	100	17	12.8	0.5~40				
Ezi-SPEED-80-H-60-C-R100-H								
Ezi-SPEED-80-H-60-A-R200-H	200	34	25	0.25~20				
Ezi-SPEED-80-H-60-C-R200-H								

120W

Unit Part Number	Gear Ratio	Permitted Torque [N·m]		Permitted Speed Range [rpm]	Unit Weight [kg]	Permitted Overhung Load [N]		Permitted Thrust Load [N]
		50~3,000 [rpm]	4,000 [rpm]			10mm from shaft end	20mm from shaft end	
Ezi-SPEED-90-H-120-A-R5-H	5	1.7	1.3	10~800	3.3	900	770	500
Ezi-SPEED-90-H-120-C-R5-H								
Ezi-SPEED-90-H-120-A-R10-H	10	3.4	2.6	5~400		1,300	1,110	
Ezi-SPEED-90-H-120-C-R10-H								
Ezi-SPEED-90-H-120-A-R15-H	15	5.1	3.8	3.3~266.7		1,500	1,280	
Ezi-SPEED-90-H-120-C-R15-H								
Ezi-SPEED-90-H-120-A-R20-H	20	6.8	5.1	2.5~200		1,500	1,280	
Ezi-SPEED-90-H-120-C-R20-H								
Ezi-SPEED-90-H-120-A-R30-H	30	10.2	7.7	1.7~133.3		1,500	1,280	
Ezi-SPEED-90-H-120-C-R30-H								
Ezi-SPEED-90-H-120-A-R50-H	50	17	12.8	1~80		1,500	1,280	
Ezi-SPEED-90-H-120-C-R50-H								
Ezi-SPEED-90-H-120-A-R100-H	100	34	25.5	0.5~40	1,500	1,280		
Ezi-SPEED-90-H-120-C-R100-H								
Ezi-SPEED-90-H-120-A-R200-H	200	68	51	0.25~20	1,500	1,280		
Ezi-SPEED-90-H-120-C-R200-H								

5.3 Dimensions of Motor with GearBox [mm]

30W

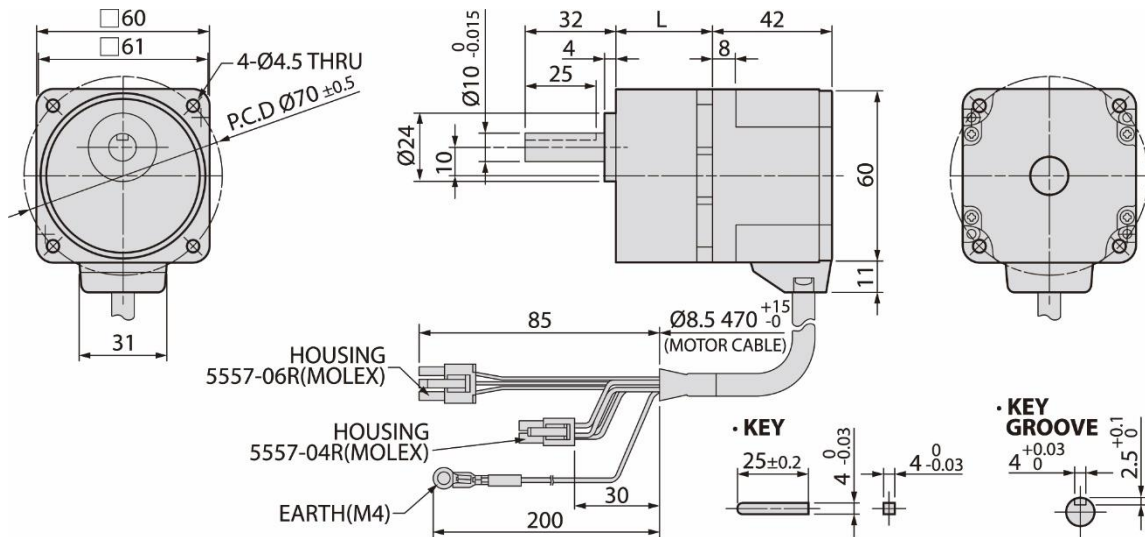

Unit Part Number	Gearbox Part Number	□Reduction Gear Ratio	Mounting Bolt	L Length [mm]
Ezi-SPEED-60-H-30-A-R□-P, Ezi-SPEED-60-H-30-C-R□-P	ESG-60-H-R□-P	5~20	M4*50	34
		30~100	M4*55	38
		200	M4*60	43

60W

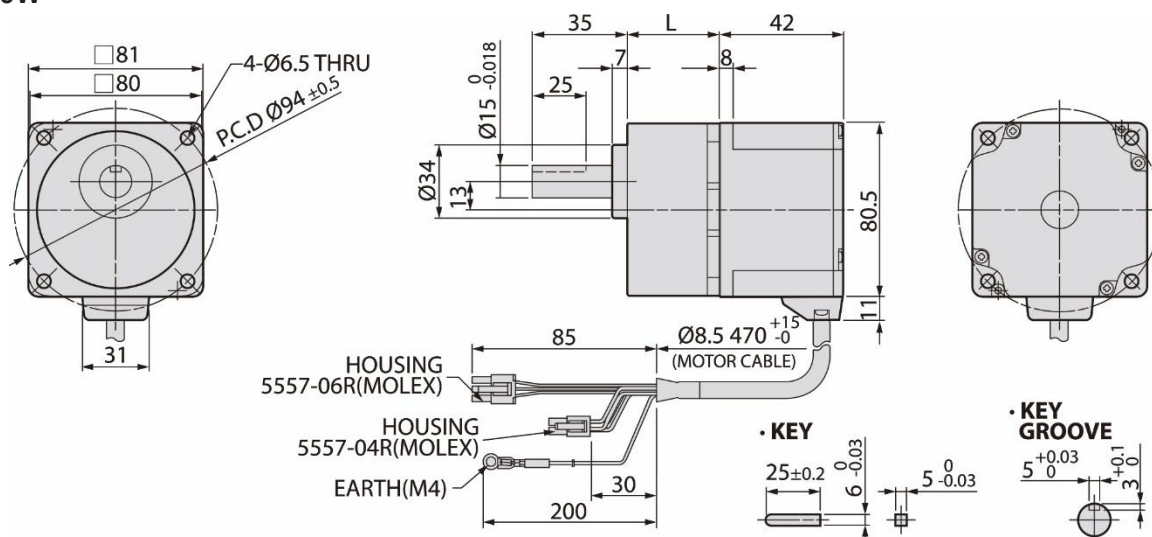

Unit Part Number	Gearbox Part Number	□Reduction Gear Ratio	Mounting Bolt	L Length [mm]
Ezi-SPEED-80-H-60-A-R□-P, Ezi-SPEED-80-H-60-C-R□-P	ESG-80-H-R□-P	5~20	M6*65	41
		30~100	M6*70	46
		200	M6*75	51

120W

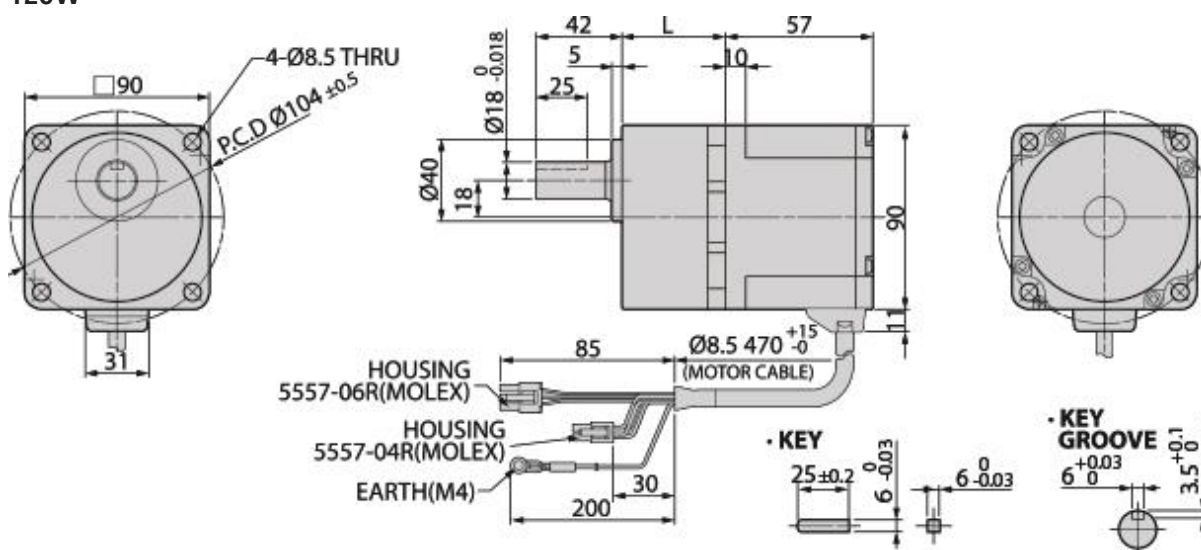

Unit Part Number	Gearbox Part Number	□Reduction Gear Ratio	Mounting Bolt	L Length [mm]
Ezi-SPEED-90-H-120-A-R□-P, Ezi-SPEED-90-H-120-C-R□-P	ESG-90-H-R□-P	5~20	M8*75	45
		30~100	M8*90	58
		200	M8*95	64

200W

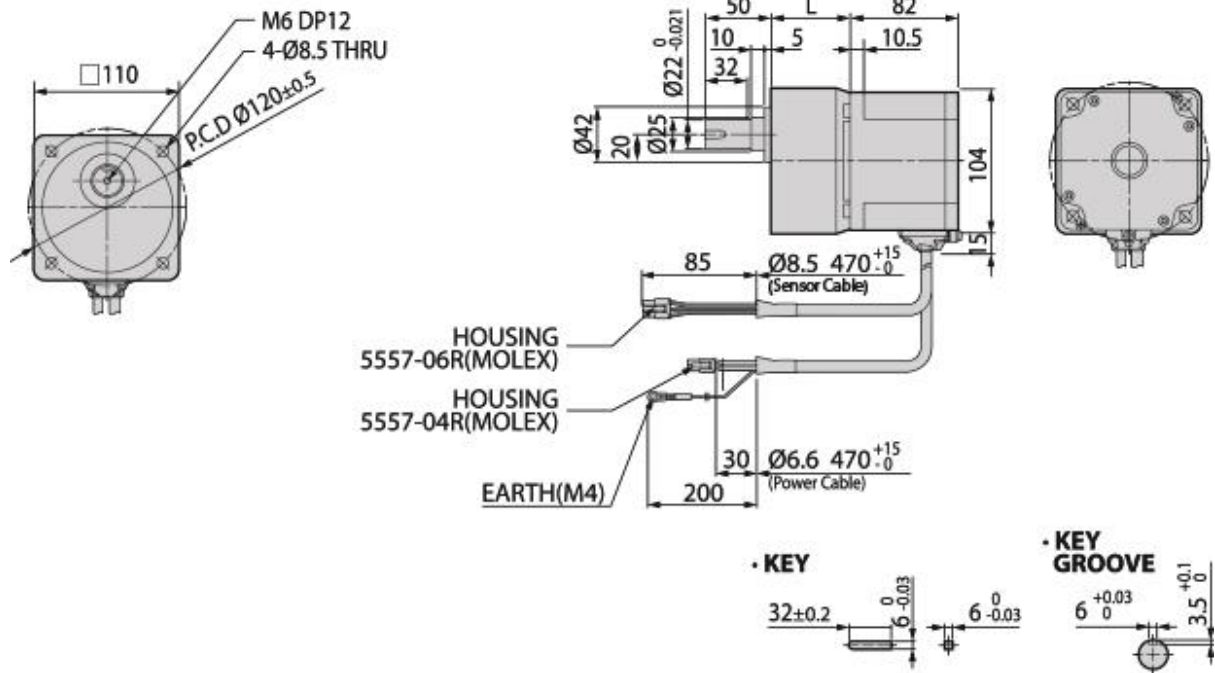

Unit Part Number	Gearbox Part Number	□Reduction Gear Ratio	Mounting Bolt	L Length [mm]
Ezi-SPEED-104-H-200-C-R□-P	ESG-104-H-R□-P	5~20	M8*95	60
		30~100	M8*110	72
		200	M8*120	86

400W

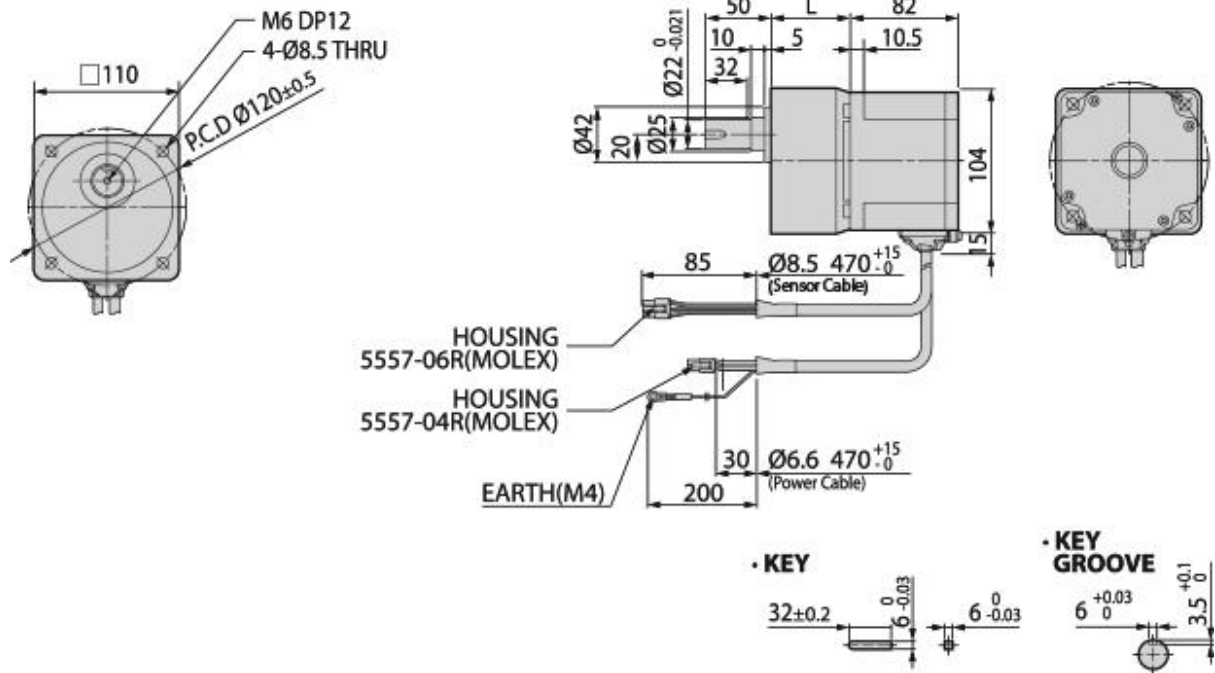

Unit Part Number	Gearbox Part Number	<input type="checkbox"/> Reduction Gear Ratio	Mounting Bolt	L Length [mm]
Ezi-SPEED-104-H-400-C-R□-P	ESG-104-H-R□-P	5~20	M8*95	60
		30~100	M8*110	72
		200	M8*120	86

5.4 Dimensions of Motor with Hollow shaft GearBox [mm]

30W

KEY GROOVE

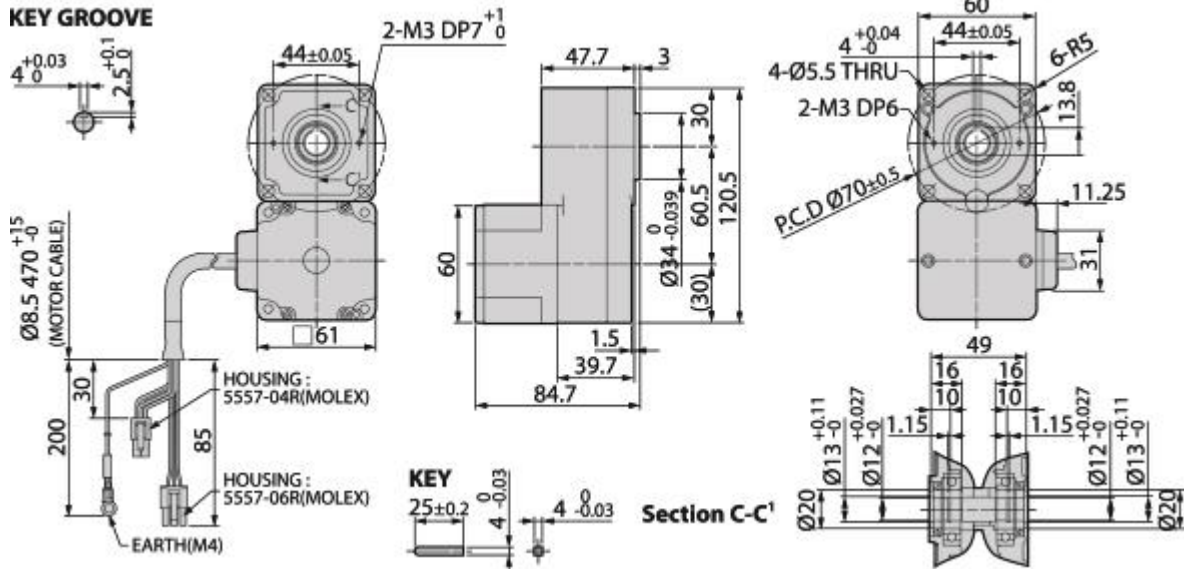

Unit Part Number	Gearbox Part Number	□Reduction Gear Ratio	Mounting Bolt
Ezi-SPEED-60-H-30-A-R□-H Ezi-SPEED-60-H-30-C-R□-H	ESG-60-H-R□-H	5, 10, 15, 20, 30, 50, 100, 200	M5*65

60W

KEY GROOVE

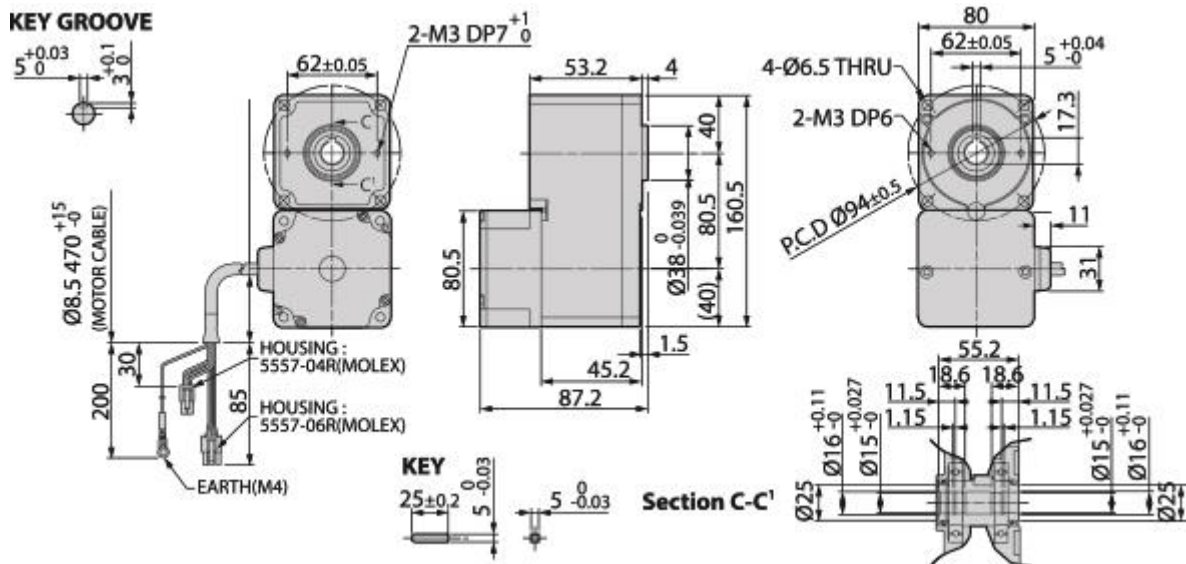

Unit Part Number	Gearbox Part Number	□Reduction Gear Ratio	Mounting Bolt
Ezi-SPEED-80-H-60-A-R□-H Ezi-SPEED-80-H-60-C-R□-H	ESG-80-H-R□-H	5, 10, 15, 20, 30, 50, 100, 200	M6*70

6. Installing and wiring

6.1 Cautions on installations

1. Be careful when opening the package. Otherwise, the product may get damaged or the user's foot may get injured by dropping the product.
2. This product has been designed for indoor use. The ambient temperature of the room should be 0°~ 40°C.
3. If the temperature of the case is 40°C or higher, radiate heat outside for cooling down.
4. Do not install in an area of direct sun, magnetic object, a radioactive material, explosive material and toxic gas.
5. Install in an area free of dust, iron powder and salt.
6. Install in an area not subject to continuous vibration or excessive shocks.
7. Install in an area free of electronic noise (from welder, power machine, etc)
8. When installing the drive, the drive front panel should be installed to the front or upper side.
9. Please install the drive on a flat metal plate with excellent durability against vibration.
10. When installing the drive to a plate, fix it with 2 mounting holes with roundhead screw and nut (M4 : Not include). Tighten the screws until no gaps remain between the drive and plate.
11. When installing 2 drives or more, there must be a clearance of 20mm or more and 50mm or more in the horizontal and vertical directions.





Attention

- Do not install any device that generate a large heat or noise near drive
- If ambient temperature of the drive exceeds 40°C, please change ventilation condition or forced cool with cooling fan.

6.2 External wiring diagram

Input Voltage 110V Drive

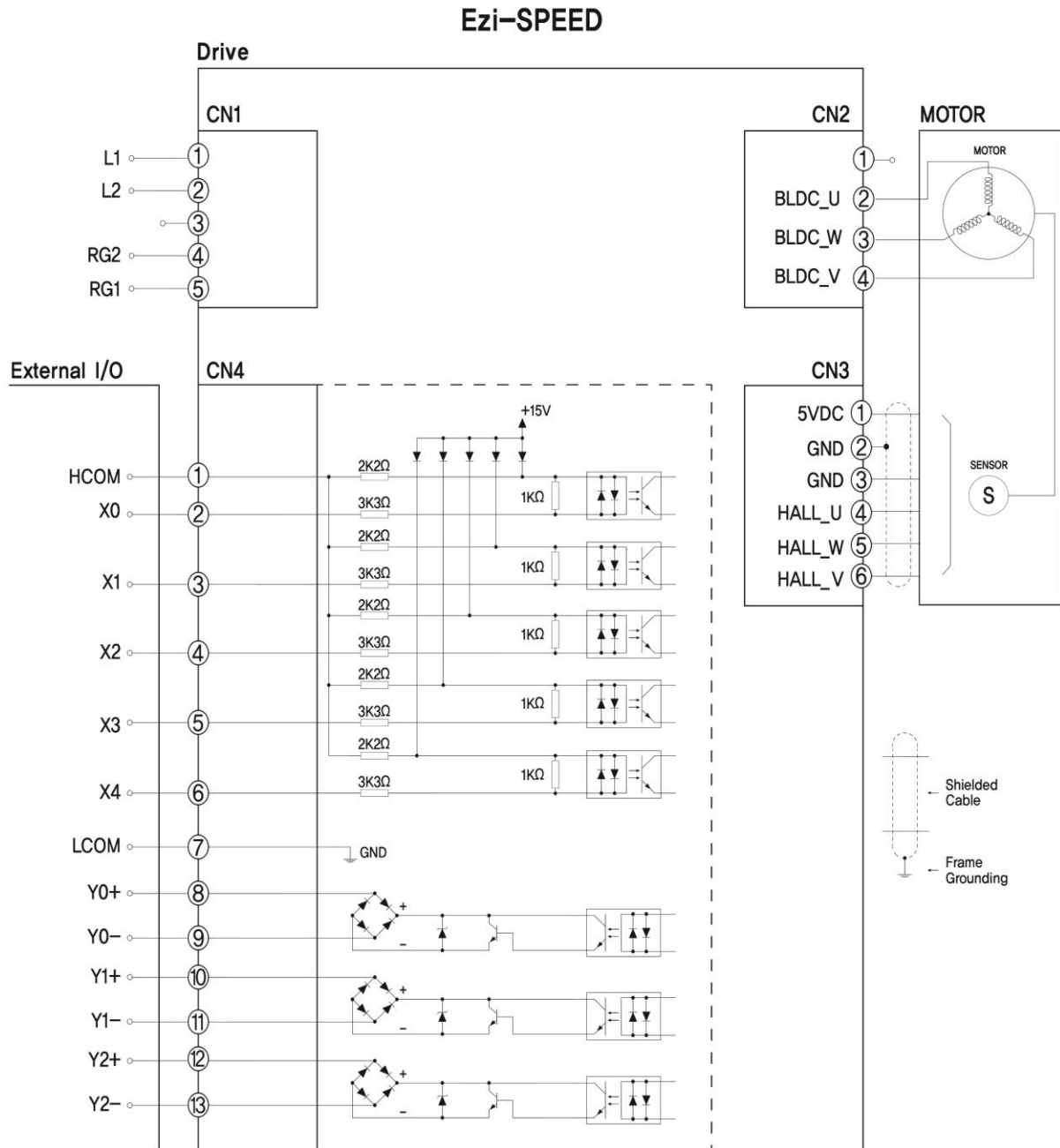

Input Voltage 220V Drive

Ezi-SPEED

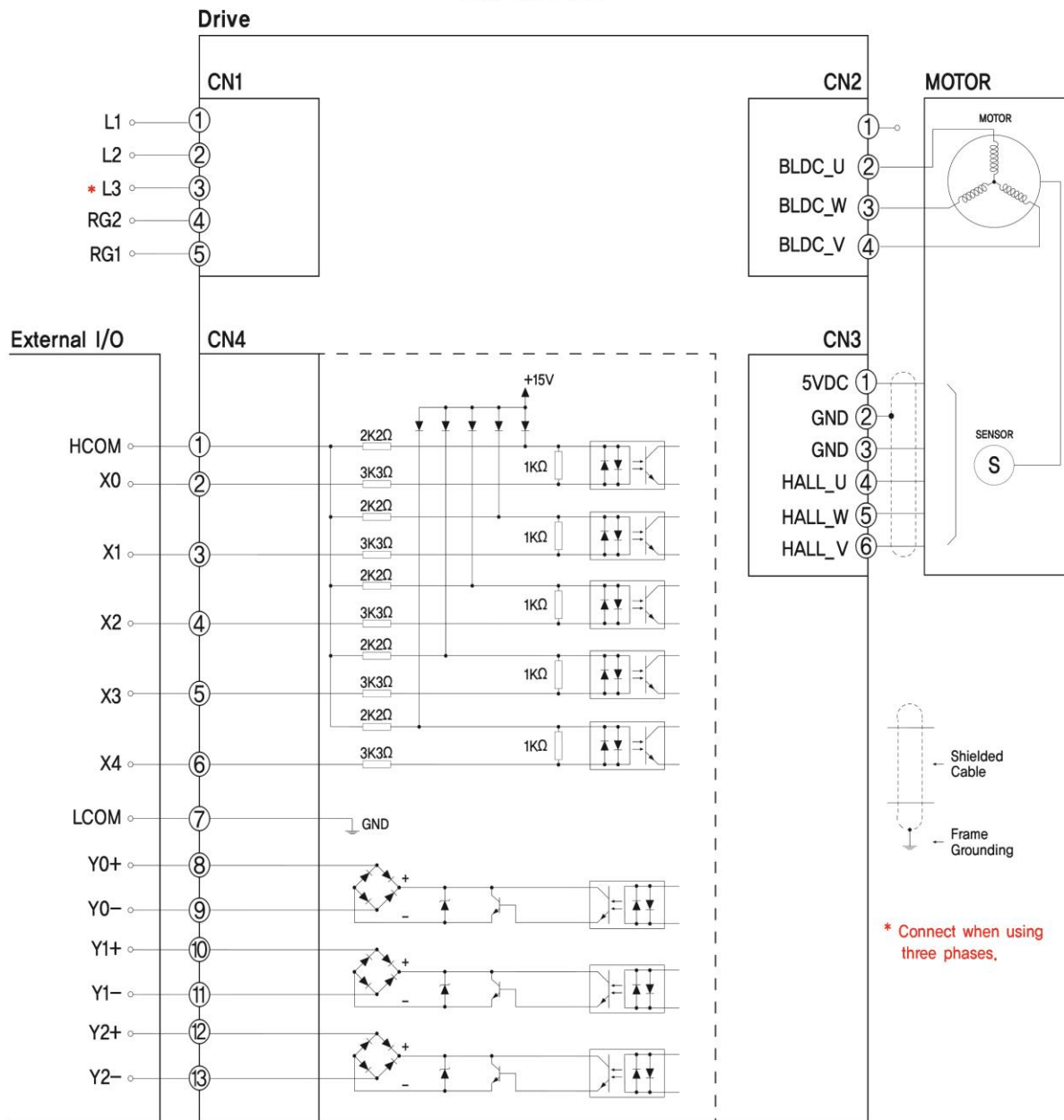

6.3 Installing the combination parallel shaft gearhead

6.3.1 Installing the gearhead

To assemble the motor and the gearhead, adjust the assembling faces together in such a way as shown in below figure and turn slowly to complete the assembly. When doing the assembly, special care should be taken neither to exert excessive force on the motor shaft nor to hit inside of the gearhead. Otherwise, the gear will get damaged, resulting in an abnormal noise and a shortened life time of the motor

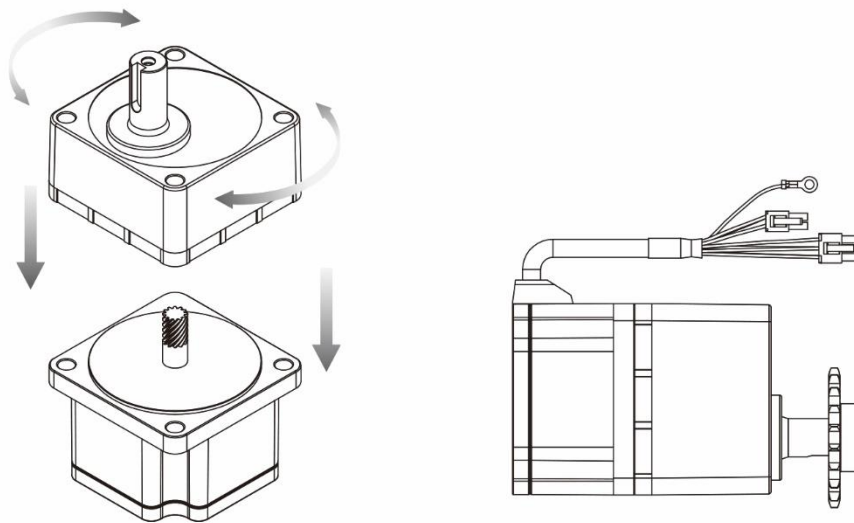

Recommended mounting hole dimensions of gearhead

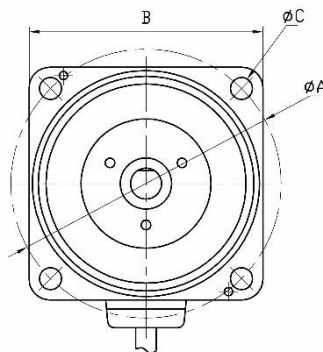

Recommended mounting hole dimensions [Unit : mm]

Model	ØA	B	ØC
30W	70	64	4*4.5
60W	94±0.1	81	4*6.5
120W	104	90	4*8.5
200W	120±0.1	104.5	4*8.5
400W	120±0.1	104.5	4*8.5

6.3.2 Removing / changing the gearhead

See the following steps to replace the gearhead or to change the cable position.

1. Removing the gearhead

Remove the hexagonal screws assembling motor and gearhead and detach the motor from the gearhead.

2. Installing the gearhead

- Using the pilot sections of the motor and gearhead as guides, install the gearhead to the motor and tighten the hexagonal screws.
- Confirm the no gaps remain between the motor flange surface and the end face of the gearhead pilot section.
- At this time, The motor cable position can be changed to a desired 90° direction.
- When installing the gearhead, slowly rotate it to prevent the pinion of the motor output shaft from contacting the side panel or gear of the gearhead.

 <p>Attention</p>	<ul style="list-style-type: none">• Do not forcibly assemble the motor and gearhead. Also do not let metal objects or other foreign matter enter the gearhead. The motor shaft or gear may be damaged. This will be reason of noise or shorter life time.• Do not allow dust to attach to the pilot sections of the motor and gearhead. Also assemble the motor and gearhead carefully by not pinching the O-ring at the motor pilot section. If the O-ring is damaged, grease may leak from the gearhead.• The Hexagonal screws assembling the motor and gearhead are used to attach the motor and gearhead temporarily. When installing the motor and gearhead assembly, be sure to use the supplied hexagonal screws.
---	--

6.3.3 Fixing method of load

When fixing a load on the motor or gearhead, pay attention the following points

- A key home is provided on the output shaft of gearhead or motor for fixing load.
- If using machining key home at chain, pulley and sprocket, etc, please use the supplied parallel key.

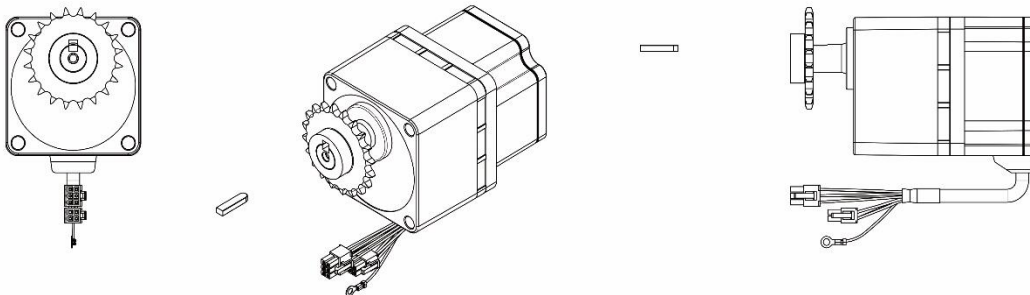



Attention

- If it will be shocked when fixing the transmission devices to gearhead, this will be a reason of damage of gearhead and shorter life time.
- When installing a load, do not damage the motor shaft (gearhead shaft) or bearing. Forcing in the load by inserting it with hammer, etc., may break the bearing.
- Do not modify or machine motor shaft (gearhead shaft). The bearing may be damaged or motor (gearhead) may break.

6.3.4 Rotation direction of gearhead and transmission efficiency

- The rotation direction of gearhead shaft is decided same rotation direction with motor and opposite rotation direct with motor on the gear ratio.
- When using decimal gearhead (ratio 1/10), the rotation diection of gearhead is same rotation direction with motor.
- The rotation direction of gearhead

Gearhead Part Number	Gear Ratio	
	Same Rotation Direction to Motor	Opposite Rotation Direction to Motor
ESG-60-H-R□-P	5, 10, 15, 20, 200	30, 50, 100
ESG-80-H-R□-P		
ESG-90-H-R□-P		
ESG-104-H-R□-P	5, 10, 15, 20, 100, 200	30, 50

- Transmission efficiency of gearhead

Gearhead Part Number	5	10	15	20	30	50	100	200
ESG-60-H-R□-P	90 %				86 %			81 %
ESG-80-H-R□-P								
ESG-90-H-R□-P								
ESG-104-H-R□-P					86 %		81 %	

6.3.5 Life time of Gearhead and Service factor

- The lifetime of the gearhead is usually determined by the method of supporting the shaft, but since the load is often changed, the factor of the service element is used depending on the type of load.
- If the gearhead is used within the permissible torque, it can be used up to 5000 hours when the rated life time is ball bearing type.
- The rated life time is the time until the decelerator stops when the motor is operated under the following conditions and the motor torque can not be transmitted to the gearhead shaft
 1. When used within the permissible torque
 2. In case of operation same rotation direction without load change.
 3. In case of operation 8 hours per day
 4. Bearing temperature : 80°C (Ball bearing type)

Service factor of above conditions is SF=1

If using ball bearing type gear head by 24 hours, service factor will be 1.5 so life time will be reduce to 1/1.5. Therefore, select the motor and gearhead with the maximum permissible torque considering the service factor.

6.3.6 Maximum permissible torque of gearhead

- The output torque of the gearhead varies greatly in proportion to the gear ratio, but the load torque applied to the reducer is limited by the gear material and other conditions.
- This is defined as the maximum permissible torque and is based on the size of gearhead and gear ratio of the gearhead. Use it within permissible torque range.

$$T_G = T_M \times i \times \tau$$

(Gearhead torque = Motor torque X gear ratio X Transmission efficiency of gearhead)

- Even if the gearhead torque is large value by calculation, do not use it at a load that exceeds the maximum permissible torque.

6.3.7 Permissible overhung load and permissible thrust load

Overhung load is a load on the gearhead shaft in the vertical direction.

- When using transmission device like chain, gear and belt, etc., overhung load on the gearhead shaft.
- Overhung load acts direct load on gearhead shaft. It affects the life time of the gearhead.
- Overhung load can be calculated by following formula.

$$W = \frac{K \times T \times f}{r} [\text{Kg}]$$

W : Overhung load [kg]

K : Weight factor by operation method

T : Delivery force to the gearhead shaft[kg - cm]

f : Service factor

r : Effectiveness radius of pulley and gear, etc.[cm]

- If the calculated overhung load value is used in excess of the permissible limit below data sheet, the bearing will be damaged within a short period of time, causing the output shaft to warp and cause fatigue damage due to repeated load.
- In this case, install in a structure that can withstand the overhung load shown in the right picture.
- Also, if a load should be directly imposed on the output shaft, please place the load as near to the gearhead as possible to avoid the one-sided load.
- When using a helical gear or a worm gear in transmission devices, make sure not to exceed both the overhung load and the thrust load simultaneously.

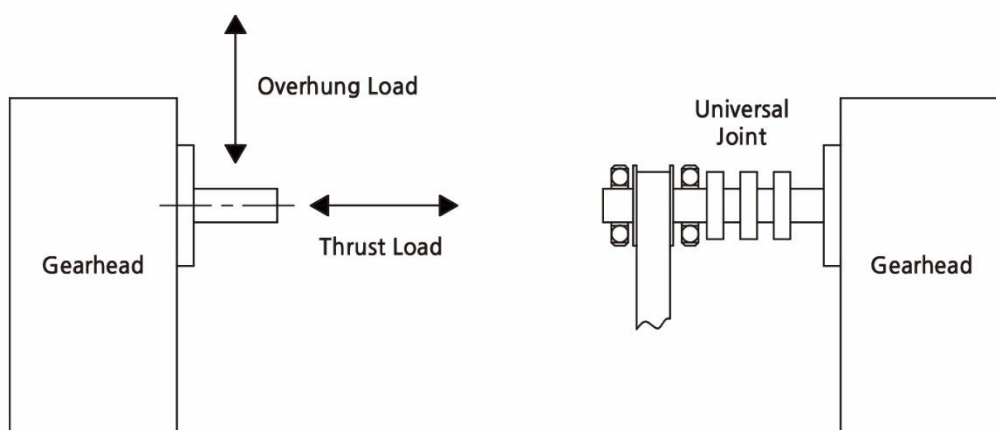

Attention

- Maximum permissible torque is different by gear ratio.
- Use within the permissible torque for each gear ratio.

Part Number		Gear Ratio	Permissible overhung load		Permissible thrust load
			10mm from shaft end	20mm from shaft end	
			N	N	
Parallel shaft gearhead mounted motor	ESM-60-H-30+ESG-60-H-R□-P	5	100	150	40
		10~20	150	200	
		30~200	200	300	
	ESM-80-H-60+ESG-80-H-R□-P	5	200	250	100
		10~20	300	350	
		30~200	450	550	
	ESM-90-H-120+ESG-90-H-R□-P	5	300	400	150
		10~20	400	500	
		30~200	500	650	
	ESM-104-H-200+ESG-104-H-R□-P	5	300	400	150
		10~20	400	500	
		30~200	500	650	
	ESM-104-H-400+ESG-104-H-R□-P	5	300	400	150
		10~20	400	500	
		30~200	500	650	

6.4 Installing the combination hollow shaft gearhead

6.4.1 Checking the parts

When opening the package, Verify that the items listed below are included.

- Hollow shaft gearhead..... 1 EA
- Hexagonal socket head bolt set..... 1 SET
(Bolt, Hexxagon nut, Flat washer, Spring washer, 4 pcs each)
- Assembly bolts for motor and gearhead 4 EA
- Safety cover1 EA
- Assembly screw of safety cover(M3)..... 2 EA
- Parallel key 1 EA
- Hollow shaft gearhead operation manual 1 EA

Item	Assembly bolts for motor and gearhead Included nut, P/W, S/W	Assembly bolts for applications Included nut, P/W, S/W	Assembly bolts for Safety cover	Key size (mm)
ESG-60-H-R □-H	M4*16L (Hexagonal socket head bolt)	M5*65L (Hexagonal socket head bolt)	M3*8L (Pan headed screw)	4*4*25-1R
ESG-80-H-R □-H	M6*16L (Hexagonal socket head bolt)	M6*70L (Hexagonal socket head bolt)	M3*12L (Pan headed screw)	5*5*25-1R
ESG-90-H-R □-H	M8*20L (Hexagonal socket head bolt)	M8*90L (Hexagonal socket head bolt)	M3*12L (Pan headed screw)	6*6*25-1R

6.4.2 Cautions on operations

- Checking the part number of motor & gearhead.
- Checking the part number of motor and gearhead that can be assembled.
- When installing gearhead, do not damage the motor shaft.
- Assembly can be done only when motor frame size and gearhead frame size are the same.
- When installing the motor and gearhead, please use the supplied screws.

Install the motor in following conditions

- Operating ambient temperature is 0~40°C, operating ambient humidity is 85% or less
- Area not exposed to direct sun and free of moisture and grease.
- Area not subject to continuous vibration or shocks or free of dust.
- Area that is free of flammable gas or corrosive gas.

6.4.3 Mounting motor and gearhead

- Do not forcibly assemble the motor and gearhead. Also do not let metal objects or other foreign matter enter the gearhead. The motor shaft or gear may be damaged. This will be reason of noise or shorter life time.
- The motor cable can not be assembled in the direction of the gearhead shaft. Cable will hit the casing of gearhead so do not wiring.
- Do not add additional adhesive to the pilot sections of the motor and gearhead. Also assemble the motor and gearhead carefully by not pinching the O-ring at the motor pilot section. If the O-ring is damaged, grease may leak from the gearhead.

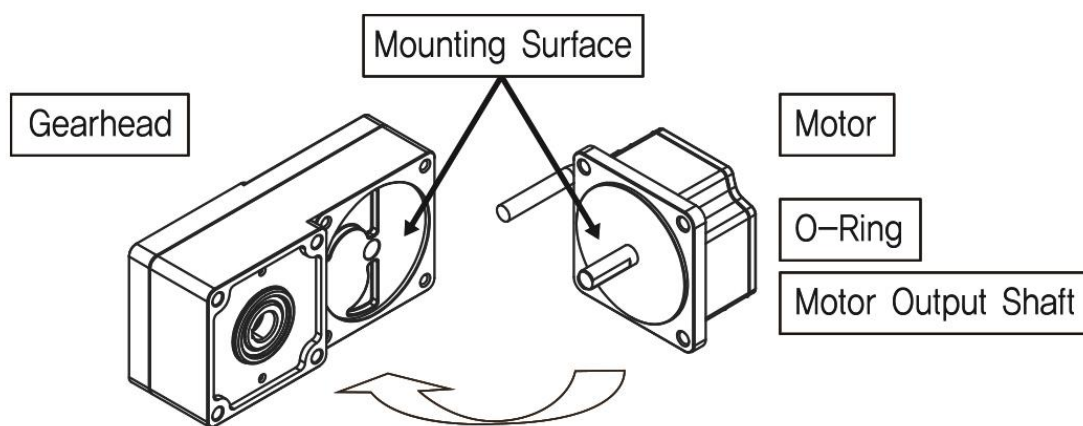

1. Assemble motor and gearhead after determine the motor cable location.
2. Mounting the motor to the gearhead.
3. Tighten the four bolts for motor and gearhead assembly.

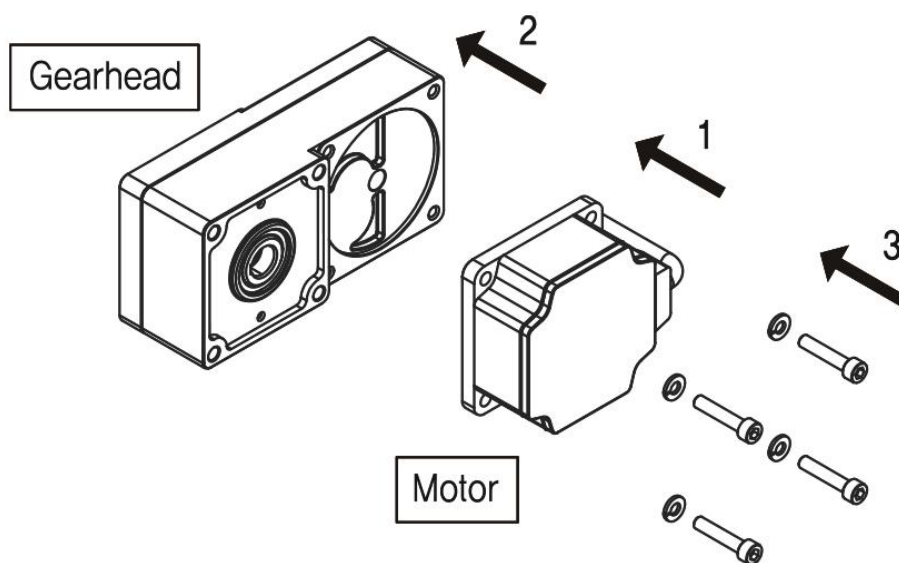

- Change the motor cable position

The motor cable can change to one of three 90 degrees directions.

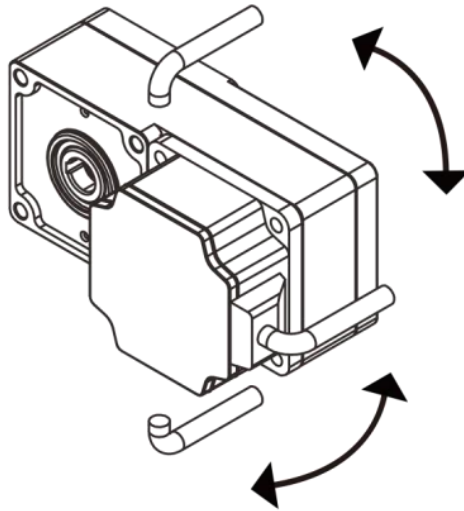

6.4.4 Installing

- Install direction

Hollow shaft gearhead can be installed by using either its front or rear side as the mounting surface.

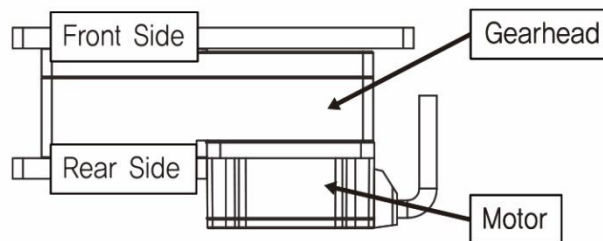

- Install method

- Gearhead do fix with the supplied hexagonal socket head bolt set to the metal machining flat plate.
- When installing gearhead, please make mounting holes in the metal machining flat plate.
- Install the supplied hexagonal socket head bolt set in the four mounting holes you opened and tighten the nuts until no gaps remain between the motor and mounting plate.
- Attached the supplied safety cover to the hollow shaft on the end opposite from the one where the load shaft is installed.

- Applicable plate thickness

The figures in the table apply when the supplied hexagonal socket head bolt is used.

Part number	Maximum applicable plate thickness(mm)
ESG-60-H-R□-H	5
ESG-80-H-R□-H	8
ESG-90-H-R□-H	12

* □ of part number indicates a number of gear ratio.

- Use the front side as the mounting surface

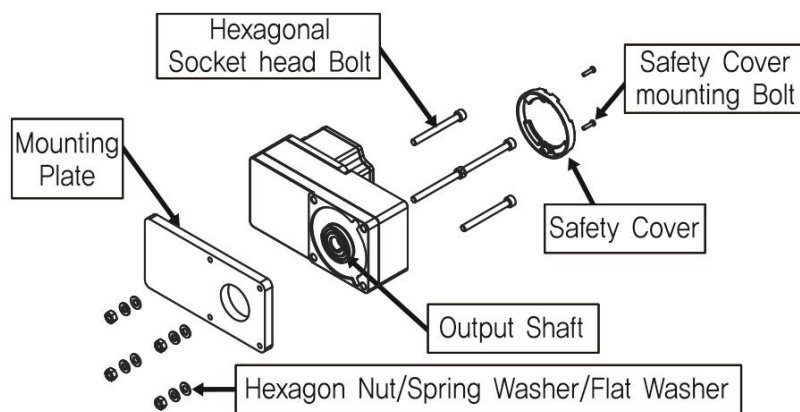

Mounting Hole Dimension : Front Side

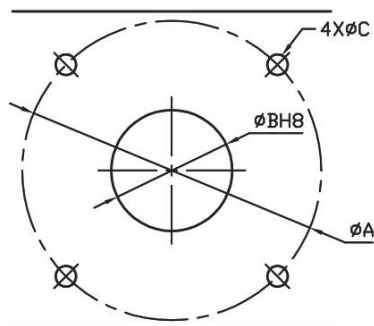

■ Use the rear side as the mounting surface

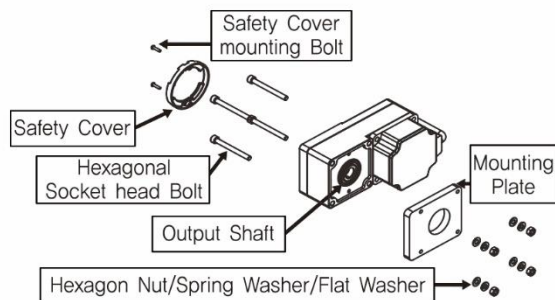

Mounting Hole Dimension : Rear Side

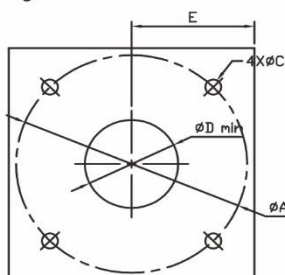

■ Note

When installing the gearhead by using its rear side as the mounting surface, prevent contact between the mounting palte and motor by keeping dimension "E" below the specified value.

Part Number	∅A	∅B H8	∅C	∅D	E
ESG-60-H-R□-H	70	34+(0~0.039)	5.5	25	29
ESG-80-H-R□-H	94	38+(0~0.039)	6.5	30	39
ESG-90-H-R□-H	104	50+(0~0.039)	8.5	35	44

* □ of part number indicates a number of gear ratio.

* Unit of mounting holes dimension is [mm]

■ Mount the load shaft

- When mounting the load shaft on the hollow shaft, align the centerline of the hollow shaft with the centerline of the load shaft.
- The hollow shaft key is grooving. Please the machining key grooving on the load shaft. Using the supplied parallel key between the hollow shaft and the load shaft for fixed. The load shaft tolerance is recommended [h7]
- If the motor received impact due to instantaneous stop or is subject to a large overhung load, please use stepped load shaft and fix with end plate. Please refer the detail of the fixing method using the end plate.

■ Stepped load shaft

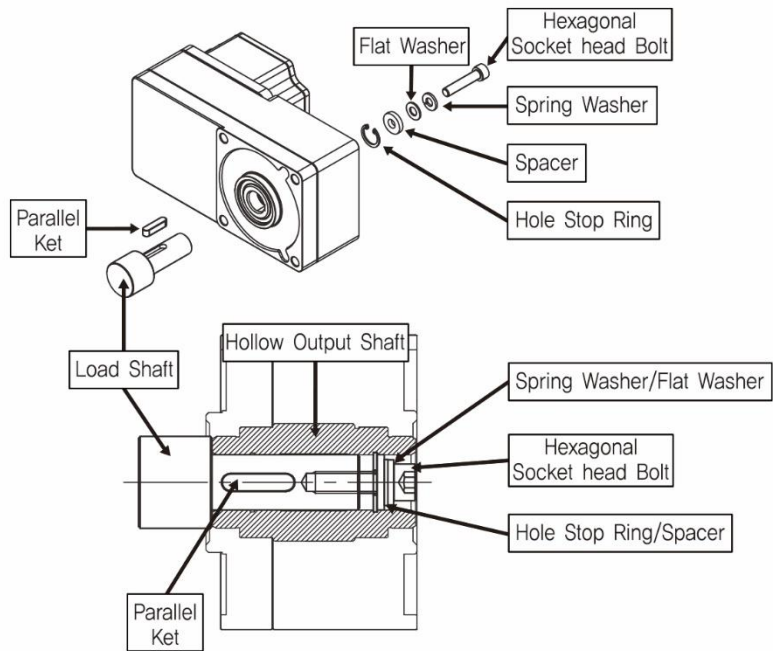

■ Fixing method using the end plate

Use the flat washer and spring washer on the end plate. Tighten with hexagonal socket head bolt.

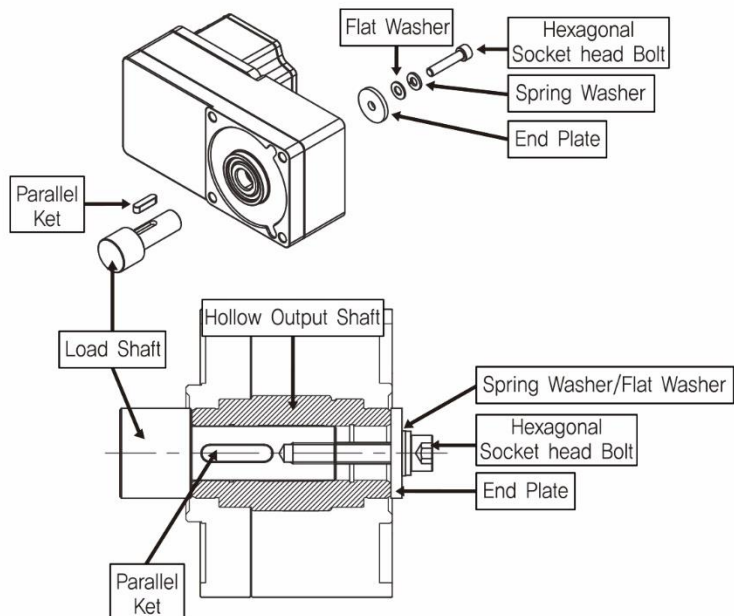



Attention

- The supplied safety cover can not be mounted because the interference in the hexagonal socket head bolt. Please make protection measures at the rotating part.

■ Non-stepped load shaft

Please put a spacer at the load shaft side. And use spacer, flat washer and spring washer to stop ring. Tighten with hexagonal socket head bolt.

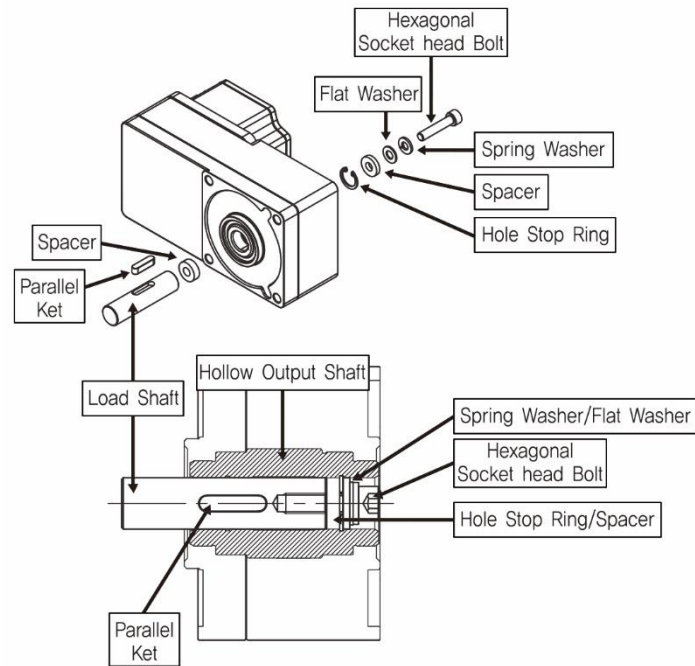

Part number	Diameter of Hollow shaft(H8)	Tolerance of load shaft(h7)
ESG-60-H-R□-H	Ø12+(0~0.027)	Ø12+(-0.018~0)
ESG-80-H-R□-H	Ø15+(0~0.027)	Ø15+(-0.018~0)
ESG-90-H-R□-H	Ø20+(0~0.027)	Ø20+(-0.021~0)

Recommended tolerance of the load shaft [mm]

Part number	Diameter of Stop ring	Applicable bolt	Spacer thickness	Diameter of stepped load shaft
ESG-60-H-R□-H	Ø 12	M4	3	20
ESG-80-H-R□-H	Ø 15	M5	4	25
ESG-90-H-R□-H	Ø 20	M6	5	30

* □ of part number indicates a number of gear ratio.

 Attention	<p>When mounting the load shaft to hollow shaft, do not damage the hollow shaft and the load shaft.</p> <ul style="list-style-type: none"> • Apply grease (Molybdenum grease, etc.) on the surface of the load shaft surface and the hollow shaft inner surface for prevent heat damage. • Do not machining and modification hollow shaft. The gearhead may be broken due to shaft may damage. • If the motor is subject to a large overhung load, please use stepped load shaft.
---	--

6.4.5 Rotation direction of gearhead and transmission efficiency

■ Rotation direction of gearhead

When viewed from the front view and the rear view, the rotation direction of hollow shaft is different.

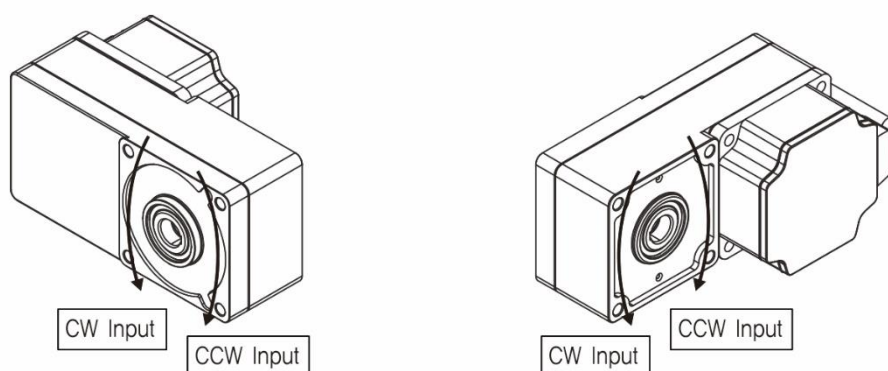

■ Transmission efficiency of gearhead

Part number	5	10	15	20	30	50	100	200
ESG-60-H-R□-H	80 %		85 %					
ESG-80-H-R□-H	85 %							
ESG-90-H-R□-H								

※ (Gearhead torque = Motor torque X gear ratio X Transmission efficiency of gearhead)

6.4.6 Maximum permissible torque of gearhead

The output torque of the gearhead varies greatly in proportion to the gear ratio, but the load torque applied to the reducer is limited by the gear material and other conditions.

This is defined as the maximum permissible torque and is based on the size of gearhead and gear ratio of the gearhead. Use it within permissible torque range.

6.4.7 Permissible overhung load and permissible thrust load

Overhung load is a load on the gearhead shaft in the vertical direction like below figure. Thrust load is a load on the gearhead shaft in the horizontal direction. Overhung load and thrust load affects the life time or strength of shaft. So please make sure not to exceed both the permissible overhung load and the permissible thrust load simultaneously with below chart.

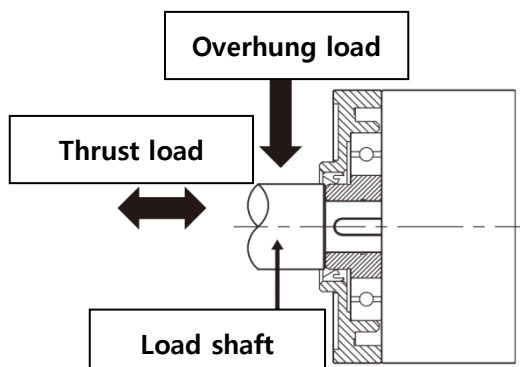

■ Permissible overhung load and permissible thrust load

Part number	Gear Ratio	Permissible Overhung load		Permissible Thrust load
		10mm from Shaft end	20mm from Shaft end	
		N	N	
ESG-60-H-R□-H	5, 10	450	370	200
	15~200	500	400	
ESG-80-H-R□-H	5, 10	800	660	400
	15~200	1200	1000	
ESG-90-H-R□-H	5, 10	900	770	500
	15, 20	1300	1110	
	30~200	1500	1280	

※ Permissible overhung load value is when motor speed is 3000rpm.

7. Setting and Operation

7.1 Exterior and names

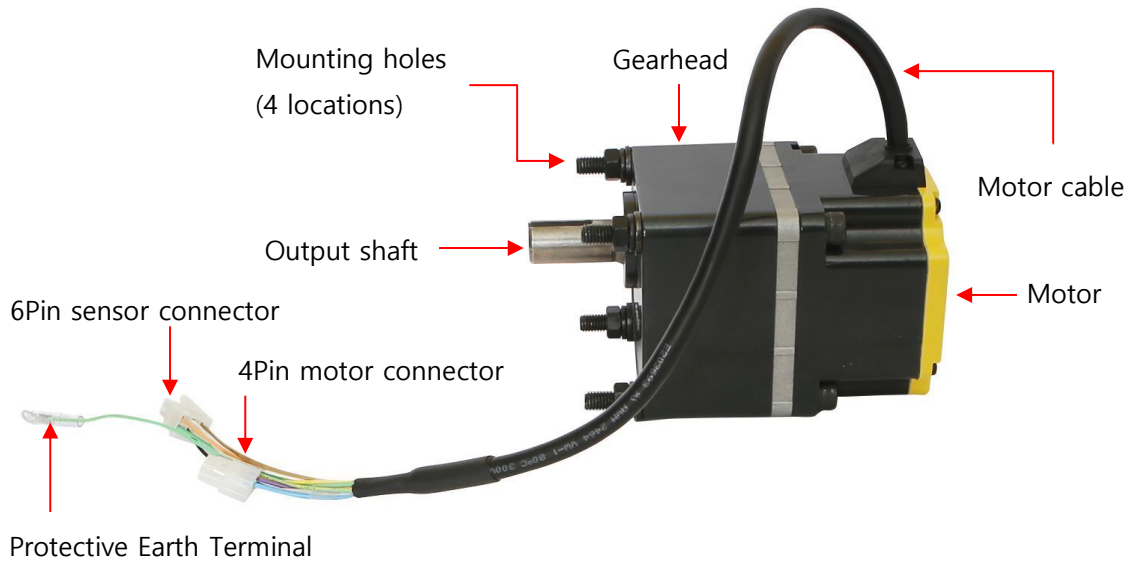

Drive

30W, 60W, 120W – 110V, 220V

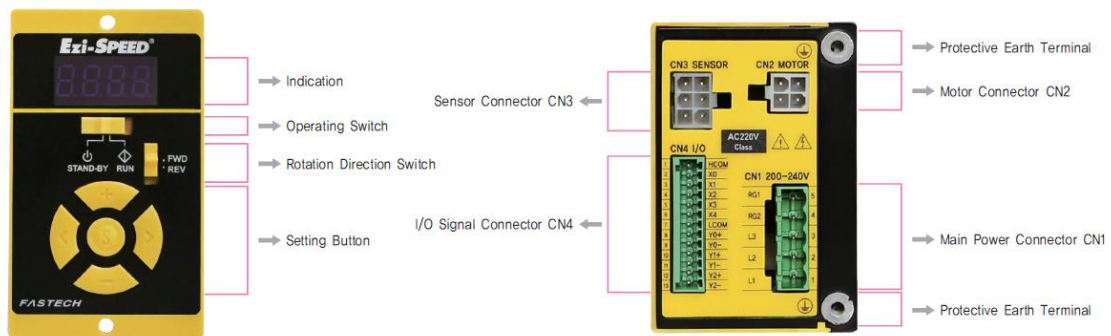



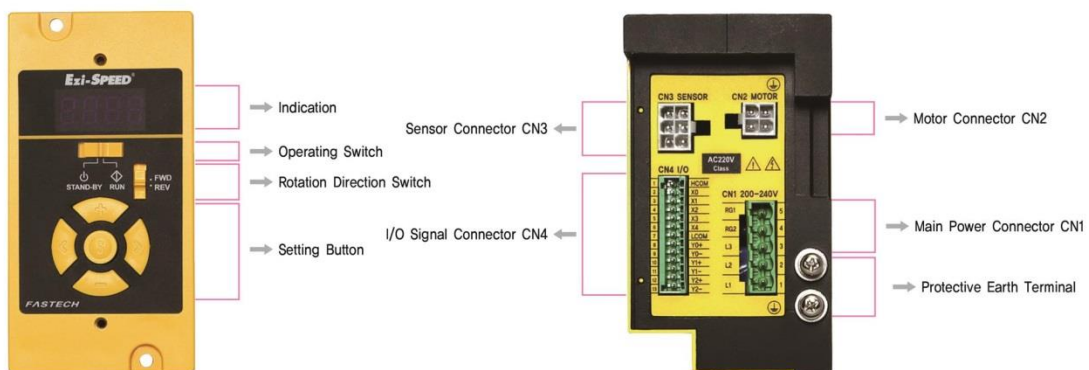



200, 400W – 220V



Display	Detail
Indication	Display the monitor, parameter, alarm, warning. etc.
Operating Switch	The motor is started by setting it to the "RUN" position. Setting it to the "STAND-BY" position stop the motor
Rotation Direction Switch	Change the rotation direction of the motor with rotation direction switch.
Setting Button	Changes the speed and parameters. The value is set when the "S" button is pressed after changes are made.
Protective Earth Terminal	Ground either one of the protective earth terminals
Sensor Connector CN3	Connects to the signal connector of the motor.
Motor Connector CN2	Connects to the power connector of the motor.
I/O Signal Connector CN4	Connects with the I/O signals.
Main Power Connector CN1	Connects to the main power supply and regenerative resistor

7.2 Rotation direction switch

When setting to FWD and REV, Motor rotation direction is different for status of rotation direction switch.
Rotation direction of below picture is from the shaft side.

Rotation Direction Switch	External Operation Input	
	FWD input	REV input
"FWD" 	Rotation direction of motor : clockwise  CW(FWD)	Rotation direction of motor : counterclockwise  CCW(REV)
"REV" 	Rotation direction of motor : counterclockwise  CCW(REV)	Rotation direction of motor : clockwise  CW(FWD)

When changing the rotation direction switch, motor will rotation of setting direction after deceleration stop.

• **Gearhead type**

The rotation direction of gearhead shaft is decided same rotation direction with motor and oppsite rotation direct with motor on the gear ratio.

Part Number	Gear Ratio	
	Same rotation direction with motor	Oppsite rotation direct with motor
ESG-60-H-R□-P	5, 10, 15, 20, 200	30, 50, 100
ESG-80-H-R□-P		
ESG-90-H-R□-P		
ESG-104-H- R□-P	5, 10, 15, 20, 100, 200	30, 50

7.3 Connecting

7.3.1 Connection the power supply

Power cable connects to CN1.

* Power cable not included. (Only connector included)



Connector : CN1

Manufacturer : STELVIO

Part number : CPF5.08-05P

 Attention	<ul style="list-style-type: none"> • Input the power after check rated voltage of drive. • If the voltage exceeds the rated range, the drive will be broken.
---------------	--

Input Power	Connect Method
Single-Phase 100-120V Single-Phase 200-240V	Wire connect to L1 and L2 terminals
Three-Phase 200-240V	Connect the R, S, and T phase lines to the L1, L2 and L3 terminals each.

Single-Phase 100-120V

Three-Phase 200-240V

Single-Phase 200-240V

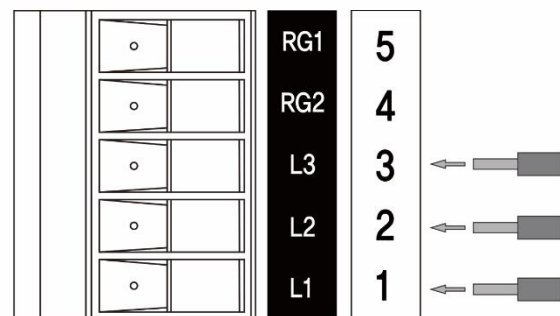
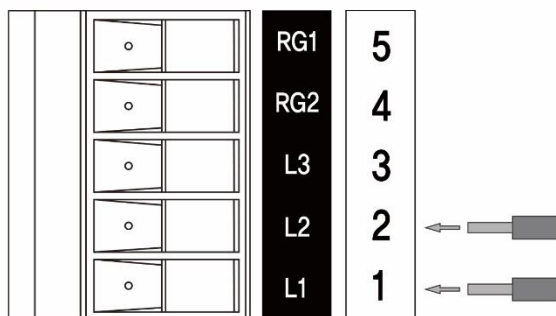

• Connecting of lead wire

- Lead wire Size : AWG18 ~ 14(0.75 ~ 2.0 mm²)
- Length of lead wire stripping : 8mm
- Conductor material : Only use copper wire.

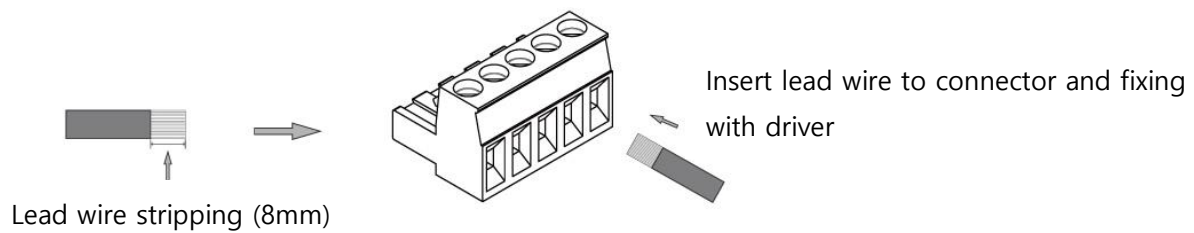

• **Molded Case Circuit Breaker**

Molded case circuit breaker connect to power supply wiring of drive for protect user's wiring.

• **Regenerative Resistor**

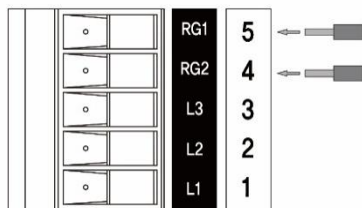

Connecting to RG1, RG2 terminals when use a regenerative resistor

A regenerative resistor can be used when the deceleration time is short or when the large inertia is driven by providing a regenerative resistor contact terminal.

Use a regenerative resistor of 100W/400Ω.

 Attention	<ul style="list-style-type: none"> • Caution when a regenerative resistor wiring. It may cause electric shock.
----------------------	---

7.3.2 Connecting the motor

Connect the motor connector (4pins) of the motor cable to CN2 and the sensor connector (6pins) to CN3. Use optional relay cable when extending between motor and drive. Up to two cables can be connected. The distance between the motor and drive can be extended up to 10m.

 Attention	<ul style="list-style-type: none"> • Please surely connect connector to drive. If not perfectly connect connector, it may cause poor movement or damaged of motor and drive.
----------------------	---

7.3.3 Ground connection

Motor and drive are sure to ground with motor ground terminal and drive ground terminal. Drive will may damage or malfunction due to static electricity.

 Attention	<ul style="list-style-type: none"> • Motor and drive are sure to ground. It may cause damage and electric shock. Drive will may damage or malfunction due to static electricity.
---	---

• Ground connection of drive

The drive has two ground terminals. Ground one of terminals to near drive. You can connect any ground terminal. The ground terminal without ground is reserved terminal. Connect the motor to ground or use the motor as required. Do not use the ground wire as a welder or a power unit.

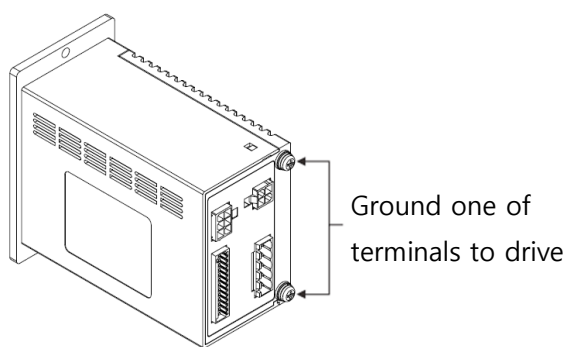

Drive of 30W, 60W, 120W
(110V, 220V)

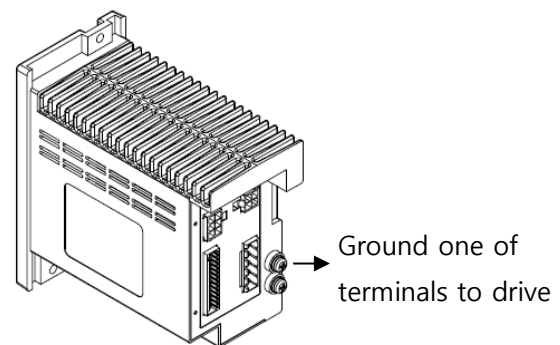

Drive of 200W, 400W
(220V)

• Ground connection of motor

Ground terminal

- Use crimp style terminal : Ring crimp style terminal with insulation
- Terminal screw size : M4

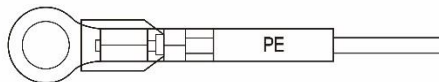

Motor ground connection

200W, 400W motor can ground directly on the motor.

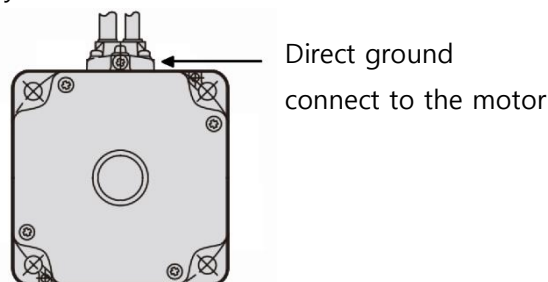

7.3.4 Connecting the I/O signals

I/O signal connects to CN4.

• Connecting the lead wire

- Lead wire size : AWG26 ~ 20 (0.14 ~ 0.5 mm²)
- Length of lead wire stripping : 8mm
- Connect with crimp style terminal

Connector : CN4

Manufacturer : DEGSON

Part number : 15EDGKD-2.5-13P-14-12A (PCB connector - Plug)

Connector part number : 15EDGKD-13P

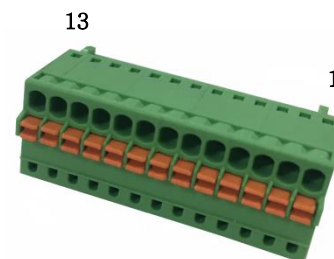

• Pin allotment of CN4

Pin No.	Terminal Name	Input/Output	Signal Name	Internal Power Supply	Ext. Pwr Source Logic	Ext. Pwr Sink Logic	Description
1	HCOM	Common			-	+	Input signal common : Sink Logic : +24V, Source Logic : 0V (GND)
2	X0	Input	[FWd]	+	+	-	The motor rotates is FWD direction during signal "ON"
3	X1	Input	[rEv]	+	+	-	The motor rotates is REV direction during signal "ON"
4	X2	Input	[P0]	+	+	-	Select the operating data
5	X3	Input	[P1]	+	+	-	Select the operating data
6	X4	Input	[A.rSt]	+	+	-	Reset the alarm
7	LCOM	Common		-			Input signal common
8	Y0+	Output	[SPd]	Free polarity	Free polarity	Free polarity	For every rotation of the motor, 30 pulses are output
9	Y0-						
10	Y1+	Output	[AL.on]	Free polarity	Free polarity	Free polarity	It turns off when an alarm is generated (Normally closed)
11	Y1-						
12	Y2+	Output	[MovE]	Free polarity	Free polarity	Free polarity	It turns on when the motor is operated (Normally opened)
13	Y2-						

* Function in [] is assigned at shipment

Can be assigned required functions to 5 input signals(X0~X4) and 3 output signals (Y0~Y2)

- Input signals : Can be used 5 functions out of FwD(CW rotation), rEv(CCW rotation), P0(operation data 1), P1(operation data 2), P2(operation data 2), A.rst(Alarm reset), E.Err(External alarm), H-Fr(Motor activation / deactivation) , t.L.OF(Torque Limit Off)
- Output signals : Can be used 3 functions out of SPd(Speed output), AL.on(Alarm output), AL.ov(Overvoltage alarm output), OvLd(Overload alarm output), Mov(Motor operation output), vA(Speed attainment alarm), WnG(Warning alarm)

• Logic of input signal

Input signal is photocoupler input. It operate with internal power (+15V) or external power. When use external power, can use sink logic input and source logic input with change wiring.

Use external power : DC24 V $-15\% \sim +20\%$, 100 mA or more

• Logic of output signal

Output signal is photocoupler and open collector output. ON voltage of output circuit is max 1.5V. When operate each element with output signal circuit, consider the ON power.

External Power : DC4.5 ~ 30 V, 100 mA or less. (For SPEED-OUT output, allow a 5mA current or more to flow.)

• In the case of using an external controller with a built-in clamp diode

If an external controller with a built-in clamp diode is used, a leakage path may form and cause the motor to operate even when the external controller power is off, as long as the drive power is on.

Since the power capacity of the controller is different from that of the drive, the motor may operate when the external controller and drive powers are turned on or off simultaneously.

When powering down, turn off the drive power first, followed by the external controller power.

When powering up, turn off the external controller power first, followed by the drive power.

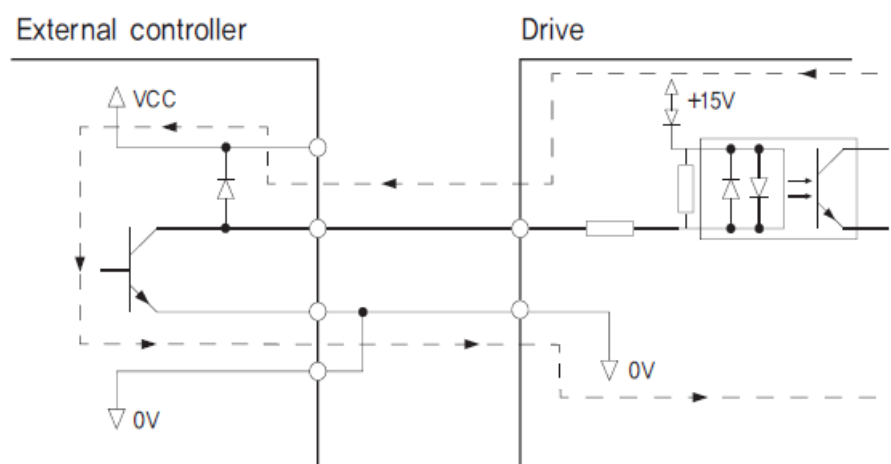

• **Connection example for I/O signals and programmable controller**

This is connection example for operating a motor using a transistor output type programmable controller.

• **SINK LOGIC (use of External Power source)**

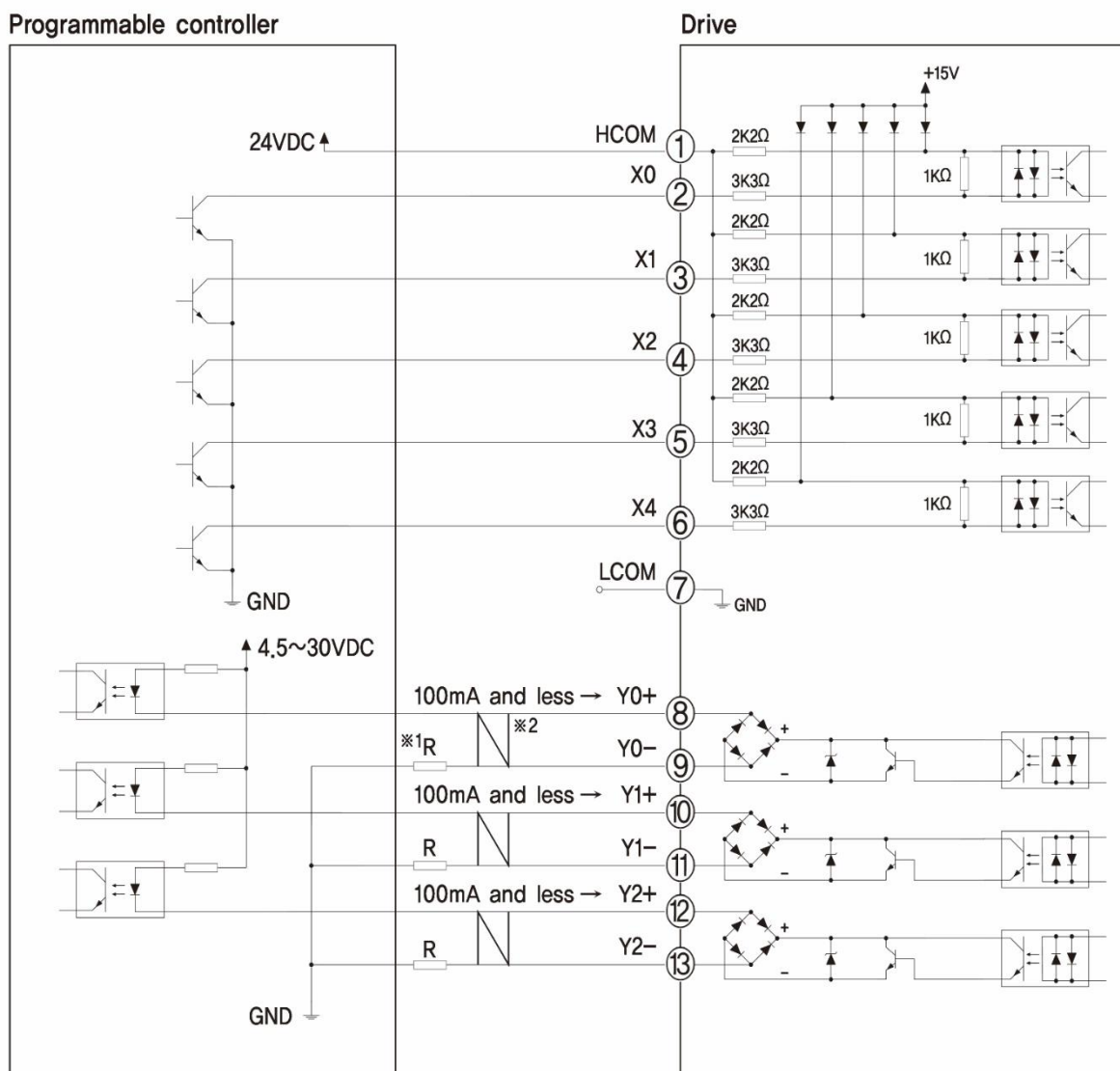

※1) Limited resistance

In the case of 24 VDC : 680Ω~2.7kΩ(2W)

In the case of 5 VDC : 150Ω~560Ω(0.5W)

※2)  Twisted Pair Shield Cable

• SOURCE LOGIC (use of External Power source)

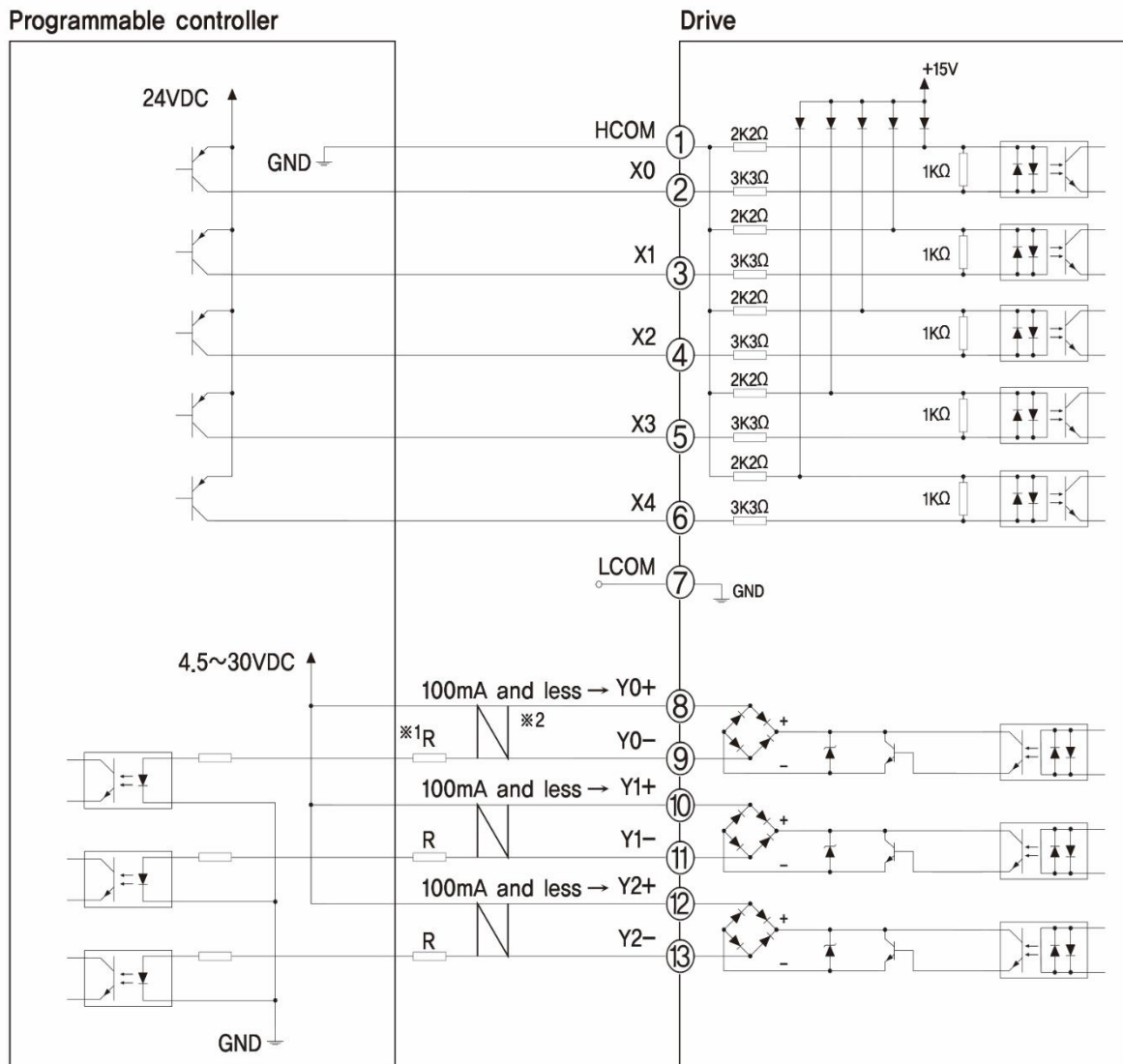

※1) Limited resistance

In the case of 24 VDC : $680\Omega \sim 2.7k\Omega (2W)$

In the case of 5 VDC : $150\Omega \sim 560\Omega (0.5W)$

※2)  Twisted Pair Shield Cable



Attention

- Power for input signal use DC20.4V ~ 28.8V, 100mA or more.
- Turn on the external power before turning on the main power of the drive.
- For the Y0, Y1 and Y2, be sure to keep the current value at 100mA or less. If the current exceeds this value, connect the limiting resistor R.

- IO Input control by Switch or Relay (use of Internal Power source)

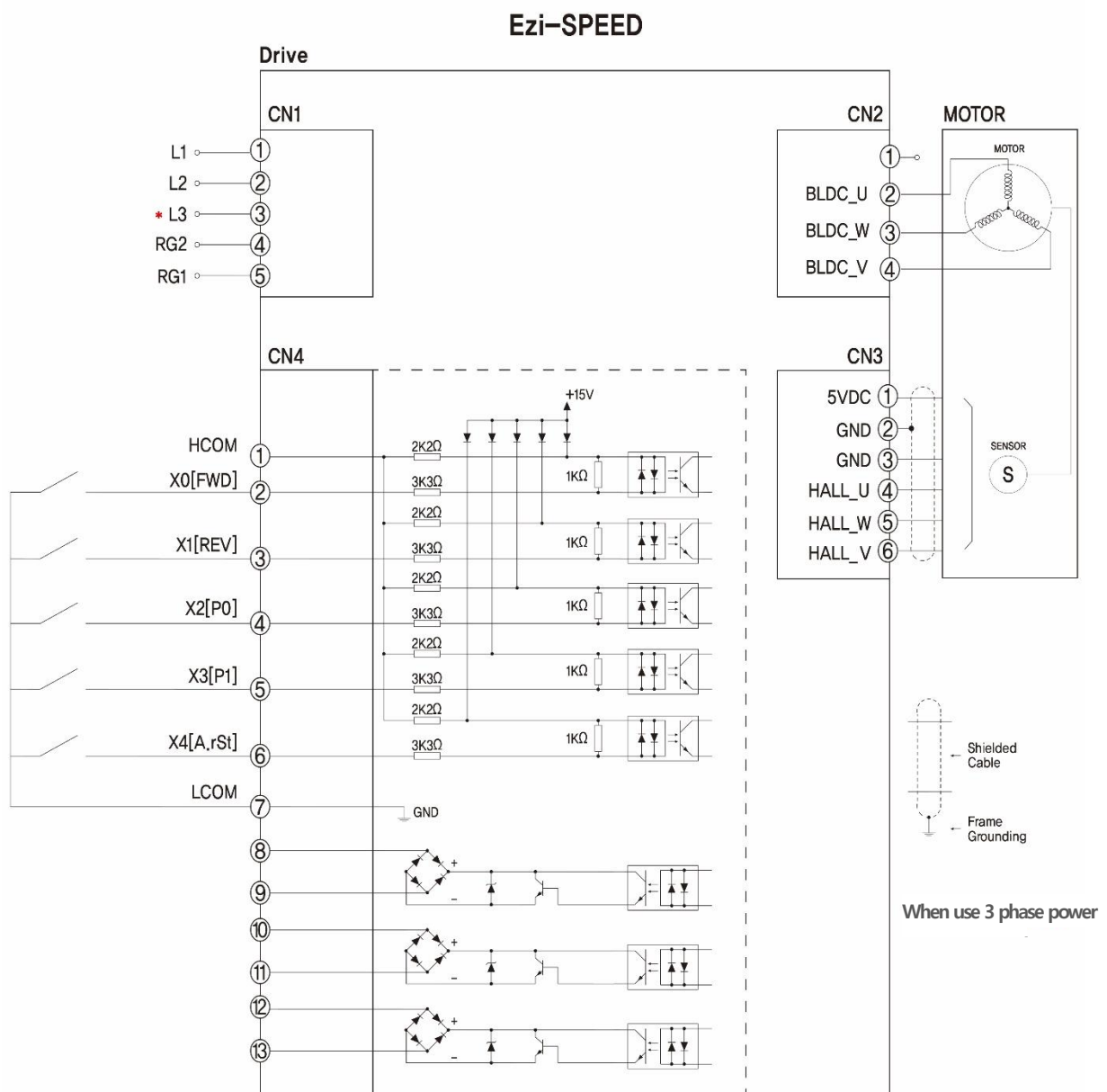



Attention

- When turning the power on again or disconnecting or re-connecting the connector, please turn off the power and wait at least 1 minute.
- Please surely connect connector to drive. If not perfectly connect connector, it may cause poor movement or damaged of product.

7.4.2 Inputting the power

Turn on the power after connect with above figure.



Indicator light
Display item : Setting speed



Attention

- If the operation switch "RUN" when power turning on, the alarm code "ALoP" (Pervation of operation at power-on alarm) is displayed and the do not operated motor. Set the operation switch from "RUN" to "STAND-BY" for release an alarm before use motor.



"Pervation of operation at power-on alarm" is refered to manual "10.1 Alarm".

7.4.3 Operating

After turning on the power, operate the product as follows.



① Running the motor

Set the operation switch to the "RUN", the motor to start rotating.

② Adjust the speed

When pressing the "+" button, the rotation speed accelerates by 1r/min increment and when pressing the "-" button, the rotation speed decelerates by 1r/min decresment.

When press and hold the "+", "-" button, RPM will acceleration and deceleration by 1rpm->10rpm-

>100rpm.

③ Determining the speed

• Set

When pressing the "S" button, the rotation speed is determined.

When the display is blinking, the rotation speed has not set.

• Confirmation

Can lock the operation by pressing the "S" button for more than 5 seconds in the "STAND-BY" mode for can not change the definite rotation speed.

④ Stopping the motor

Setting the operation switch to the "STAND-BY" side causes the motor to decelerate to a stop.

Setting the operation switch again to the "RUN" side causes the motor to start rotating at the set rotation speed.

• Changing the rotation direction

Change the rotation direction of the motor (gearhead) using the rotation direction switch. The rotation direction can be changed while operating. With the combination type, the rotation direction of the gearhead output shaft varies depending on the rear ratio of the gearhead.

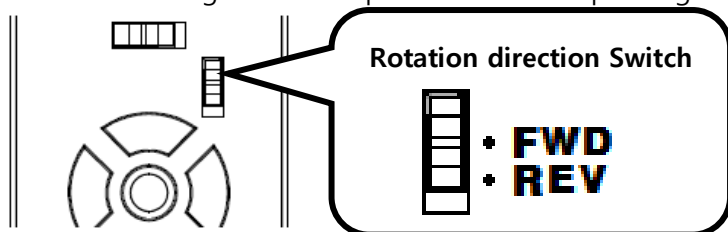

Refer to manual "7.2 Rotation direction switch" for detail.

7.4.4 Reading of 7-Segment

Can read the Arabic numerals and alphabets displayed on the 7-segment as follows.

• Arabic numerals

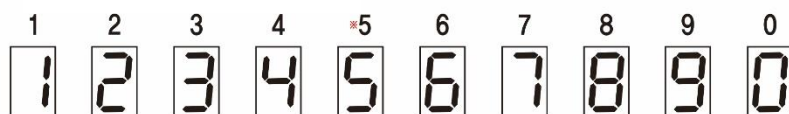

• Alphabets

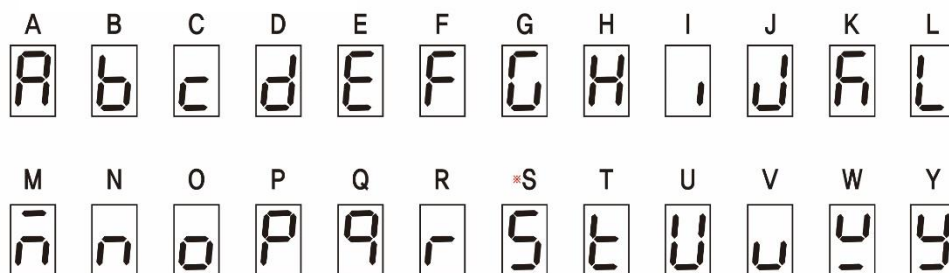

*Please note that the Arabic numerals "5" and the letter "S" shown above are displayed identically.

7.5 Operating by I/O signals

7.5.1 Operating

The motor can be operated and stopped from the external signals.

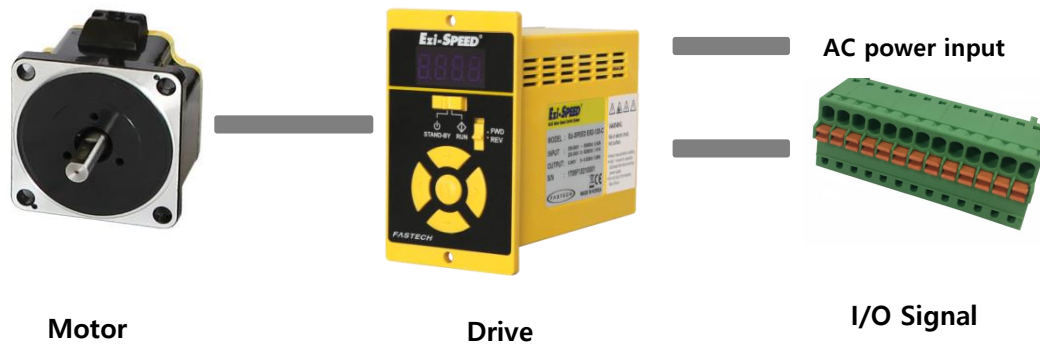

Set and operate as follows after operation input (FWD input, REV input) connect to CN4.

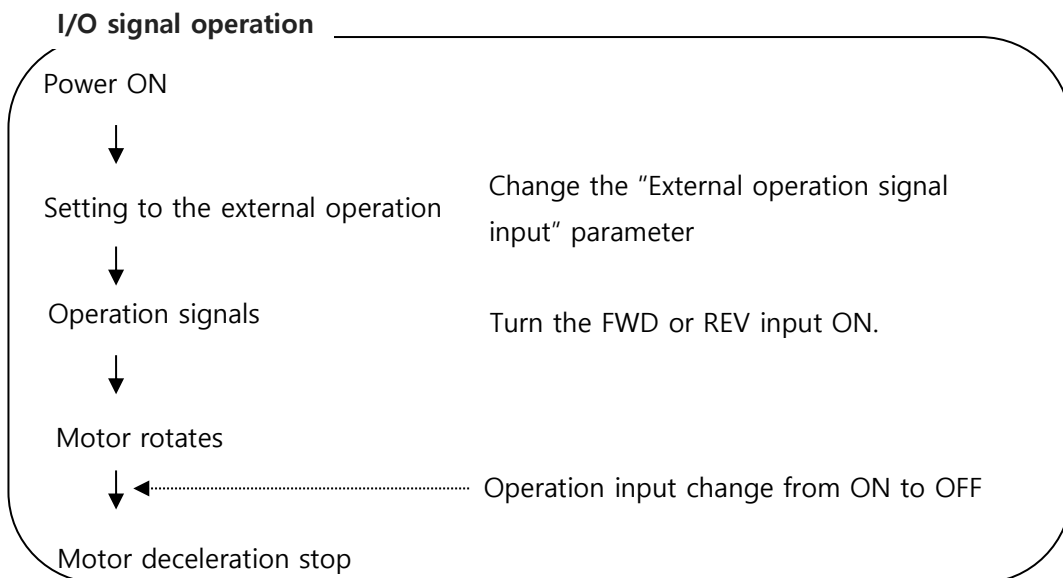

• Setting the "External operation signal input" parameter

The "External operation signal input" parameter (Par -> ioEn -> on / oFF) is required to change the setting when operating or stopping the motor externally. The factory setting is "OFF"

When "The "External operation signal input" parameter is ON, External I / O control is enabled, but the front control of the drive is disabled. When "The "External operation signal input" parameter is OFF, External I / O control is disable, but the front control of the drive is enabled.

- **Precaution of “External operation signal input” parameter setting**

“Wn.oP” warning generates when I/O Enable is ON after I/O activated when “I/O Enable” is OFF status. Set the "External operation signal input" parameter of the drive while I / O connection is stopped.

- **Timing chart example**

In case of parameter “external operation signal input” to “on” and the rotation direction switch is set to “FWD”.

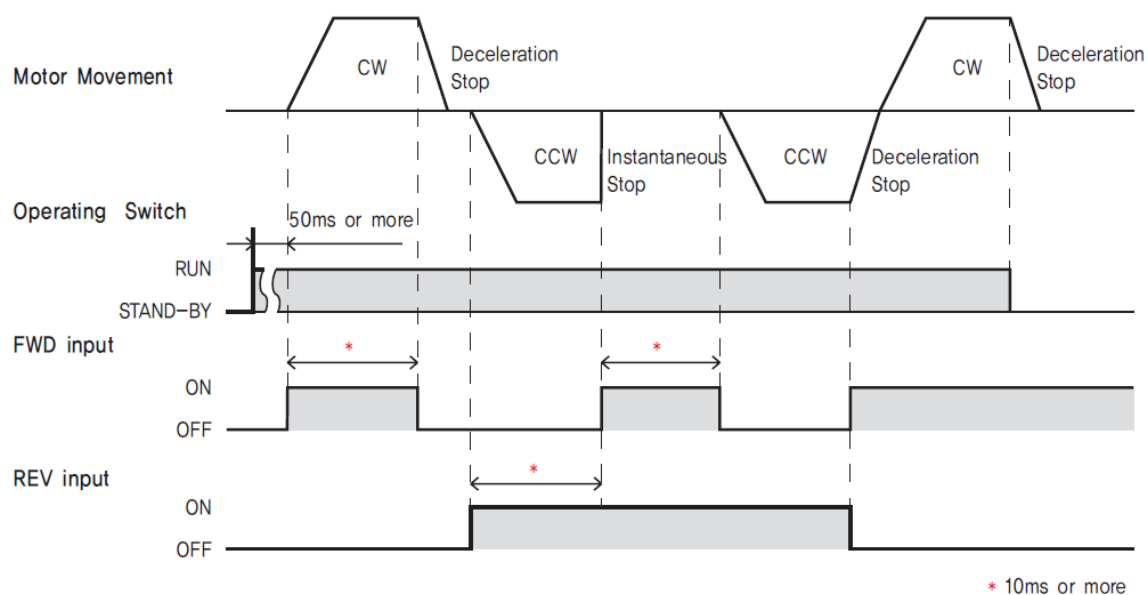

※ **Operation input**

- The motor rotates when either FWD input or REV input is set to “ON”.
- The motor instantaneous stop when FWD input and REV input is set to “ON” at the same time.
- Stop movement can differ according to gear box and load inertia.

7.5.2 Operating with multiple speeds

The operation at a speed of two or more can be performed by switching the external input. Up to 8 speeds can be performed.

• **Data setting method [Example : Set the rotation speed to 3000rpm (Change from 0 rpm)]**

Refer to manual "8.2 Setting and 7-segment display" about display of 7-segment.

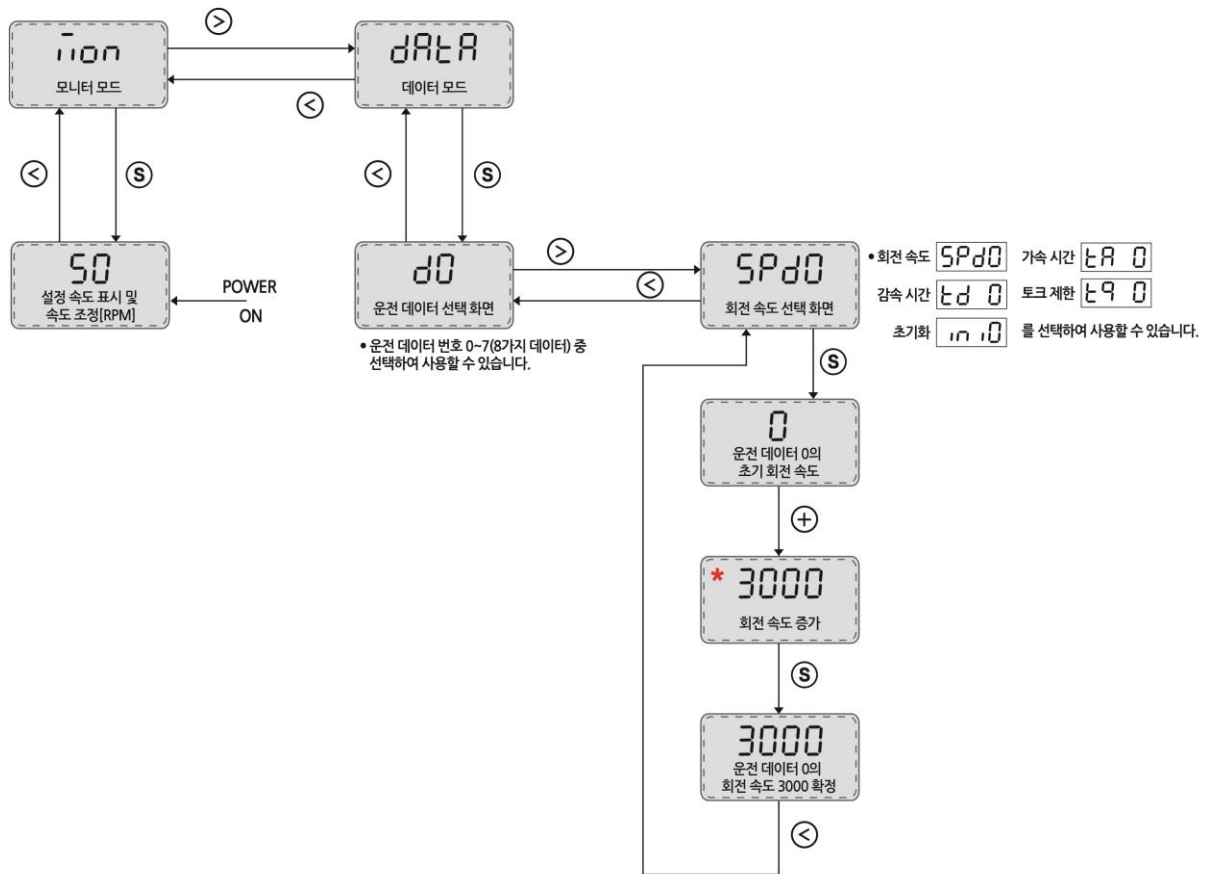

• **Operating method**

Operate the motor by selecting any of the operation data No.0 to No.7 based in a combination of ON/OFF status of the P0, P1 and P2 inputs. The motor is operated using the rotation speed, acceleration time, deceleration time and torque limit in the selected operation data number.

• **Operation procedure (When the “external operation signal input” parameter is set to “ON”)**

1. Set the operation switch to “RUN” side
2. Select the operation data number using the P0, P1 and P2 inputs
3. When the FWD or REV input is turned ON, the motor will rotate.
4. Switch the operation data number using the P0, P1, and P2 inputs
5. When the FWD or REV input switch has been turned ON or is turned OFF, the motor will stop.

Operation data number	P0	P1	P2	Rotation speed [rpm]
0	OFF	OFF	OFF	1000
1	ON	OFF	OFF	500
2	OFF	ON	OFF	2000
3	ON	ON	OFF	1500
4	OFF	OFF	ON	3000
5	ON	OFF	ON	2500
6	OFF	ON	ON	4000
7	ON	ON	ON	3500

* Setting speed value is example, can be changed to needed speed.

When changing from the present speed to the new speed, the acceleration time and deceleration time set in the next operation data number are used.

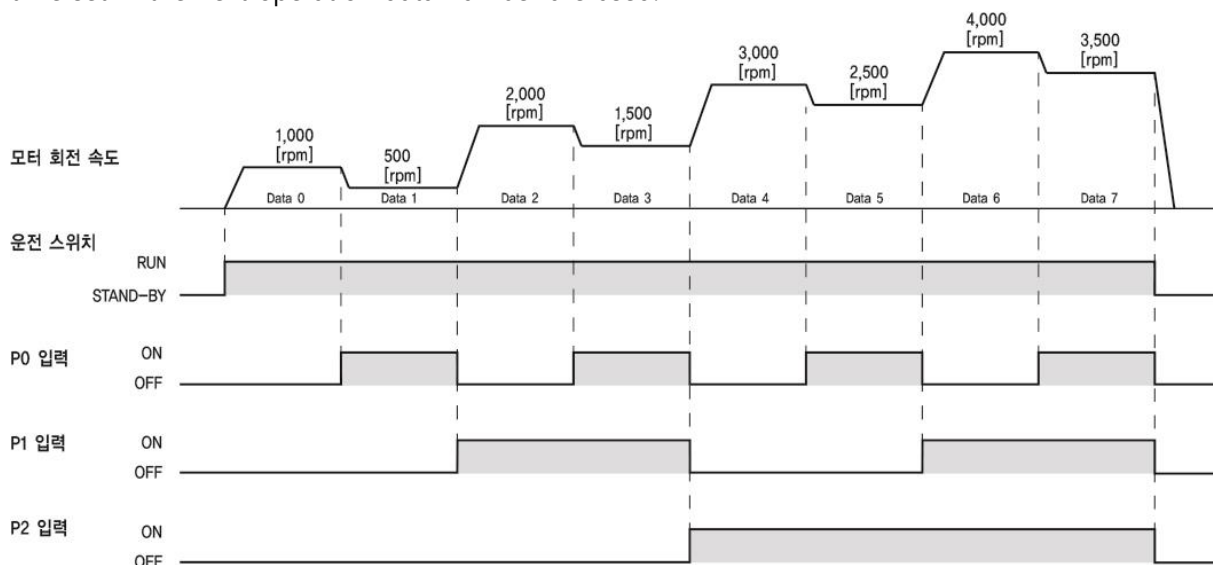

7.5.3 "Torque Limit OFF" function control using IO input

When "t.L.oF" parameter is enabled, predefined torque settings of tq0 ~ tq7 are ignored and default 300% is used as a torque limit value.

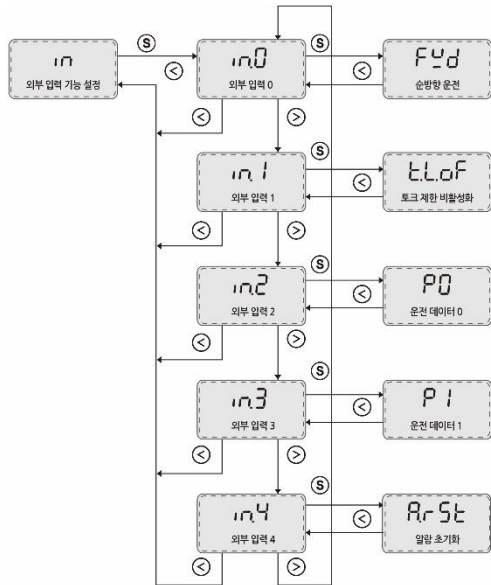

Parameter In setting	Setting value
In0	FWD
In1	t.LoF
In2	P0
In3	P1
In4	Arst

Data	P0	P1	Rot speed [rpm]	Torque Limit [%]
Data0	OFF	OFF	500	50
Data1	ON	OFF	500	100
Data2	OFF	ON	1000	50
Data3	ON	ON	1000	100

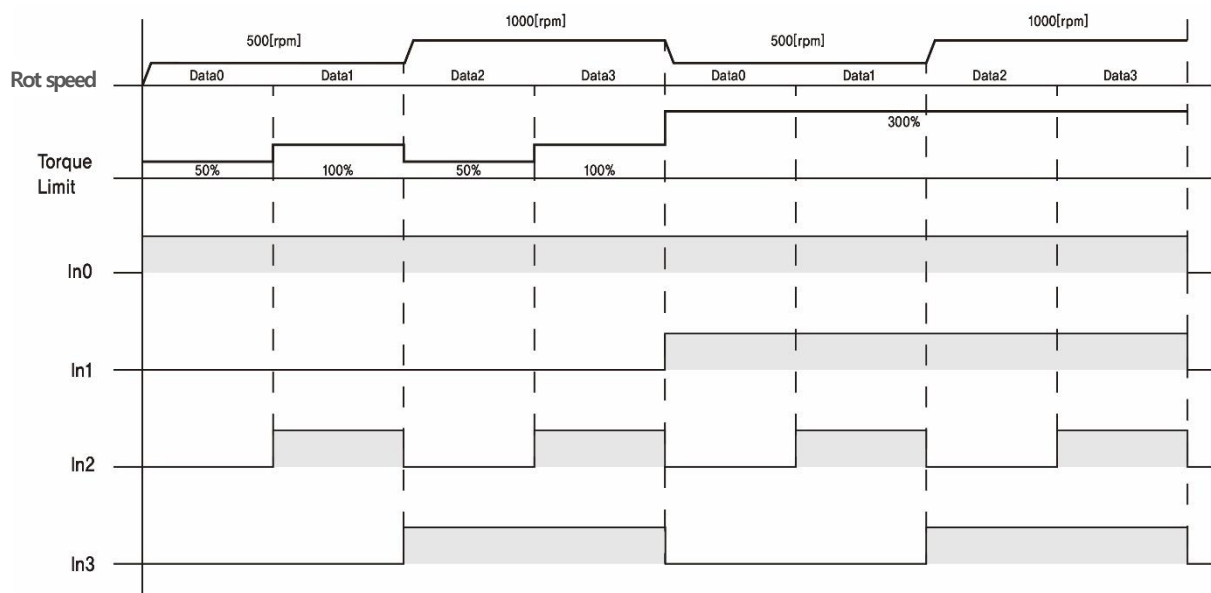

7.5.4 Velocity setting using front panel buttons when operating with IO IN

When operating with IO IN, Velocity can be set using front buttons instead of Data mode setting. If we do not set any of P0, P1 or P2 on in.0 ~ in.4, then we can set velocity using up/down buttons on front panel.

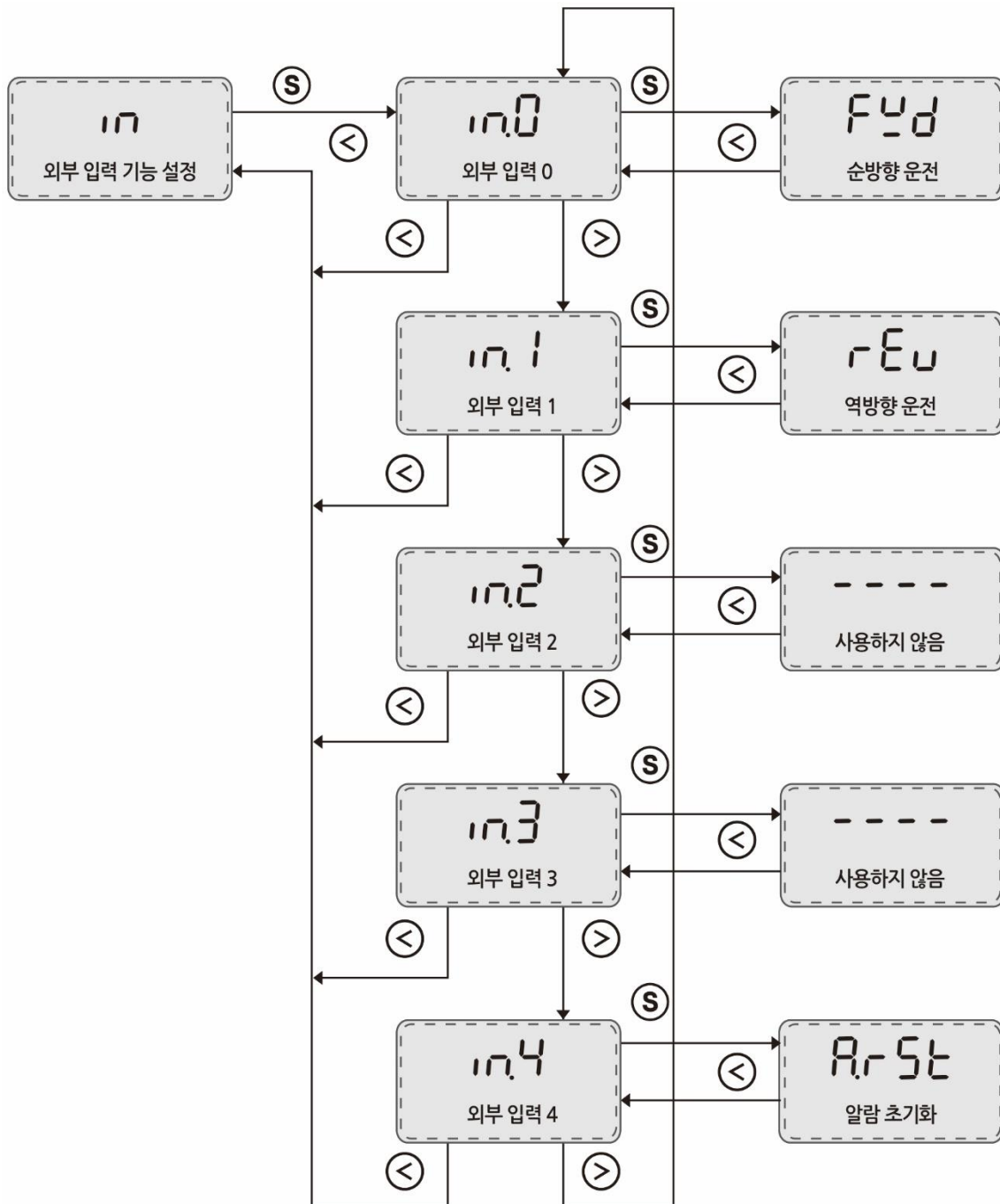

8. Convenient functions

8.1 Function list

Functions		Description	Reference contents
Display	Rotation speed	Display the rotation speed of the motor output shaft.	7.4.2
		Display by converting the motor rotation speed into the rotation speed of the gearhead output shaft.	8.4
	Conveyor speed	Display by converting the motor rotation speed into the transfer speed of the conveyor drive.	8.4
	Speed increasing	Display converting the motor rotation speed into the increasing speed.	8.4
	Actual rotation speed	Display the actual rotation speed of the motor output shaft.	8.4
	Load factor	Display the load torque applied on the motor output shaft as a percentage (%).	8.4
	Alarm	Display the alarm information by the alarm code.	8.4
		Display the alarm records.	10.1
	Warning	Display the warning information by the warning code.	8.4
		Display the warning records.	10.2
	Operation data number	Display the operation data number that is presently operating.	8.4
I/O signals	Checks whether a signal is input.	7.3.4, 7.5, 8.4	
	Checks whether a signal is output.		
Setting	Rotation speed	Sets the motor rotation speed using the setting button.	7.4.3
		Sets the motor rotation speed in the operation data.	7.5.2
	Acceleration time, Deceleration time	Sets using acceleration/deceleration time parameter.	8.6
		Sets the acceleration/deceleration time in the operation data..	7.5.2
	Setting of torque limit	Sets the torque limit.	7.5.2
		Sets the torque limiting the operation data.	
	Limiting the setting range of the rotation speed	Sets the upper limit and lower limit of the rotation speed.	8.9
	Operating using I/O signals inputs	Operates by inputting signals externally.	7.3.4, 7.5
Disables an operation with the setting button on the front panel.		8.4	

		Operates with multiple speeds (up to 8 speeds)	7.5.2, 8.5
	Lock function	Disables an operation with the setting button so that the set data can not be changed.	8.8
	Changing the function for I/O signals	Changes the functions assigned to the input signals (5 input signals).	7.3.4
		Changes the functions assigned to the output signals (3 input signals).	
	Initial display at power ON	Changes the display item when turning on the power.	8.3
	Data initialization	Restores the parameter to the factory setting (initial value).	8.3
		Restores the operation data to the factory setting (initial value).	8.3

8.2 Setting and 7-segments display

1. Monitor mode

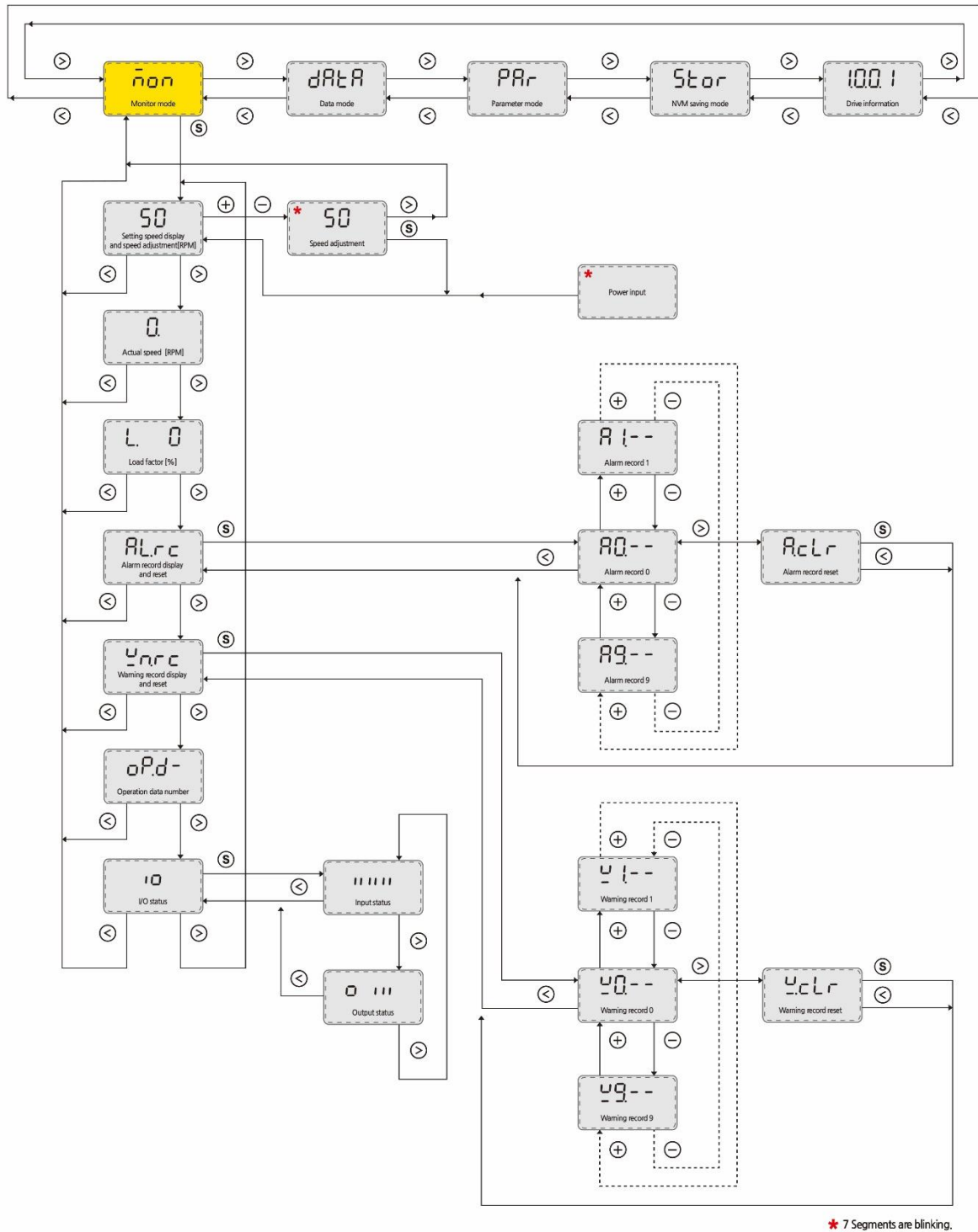

2. Input/Output setting mode

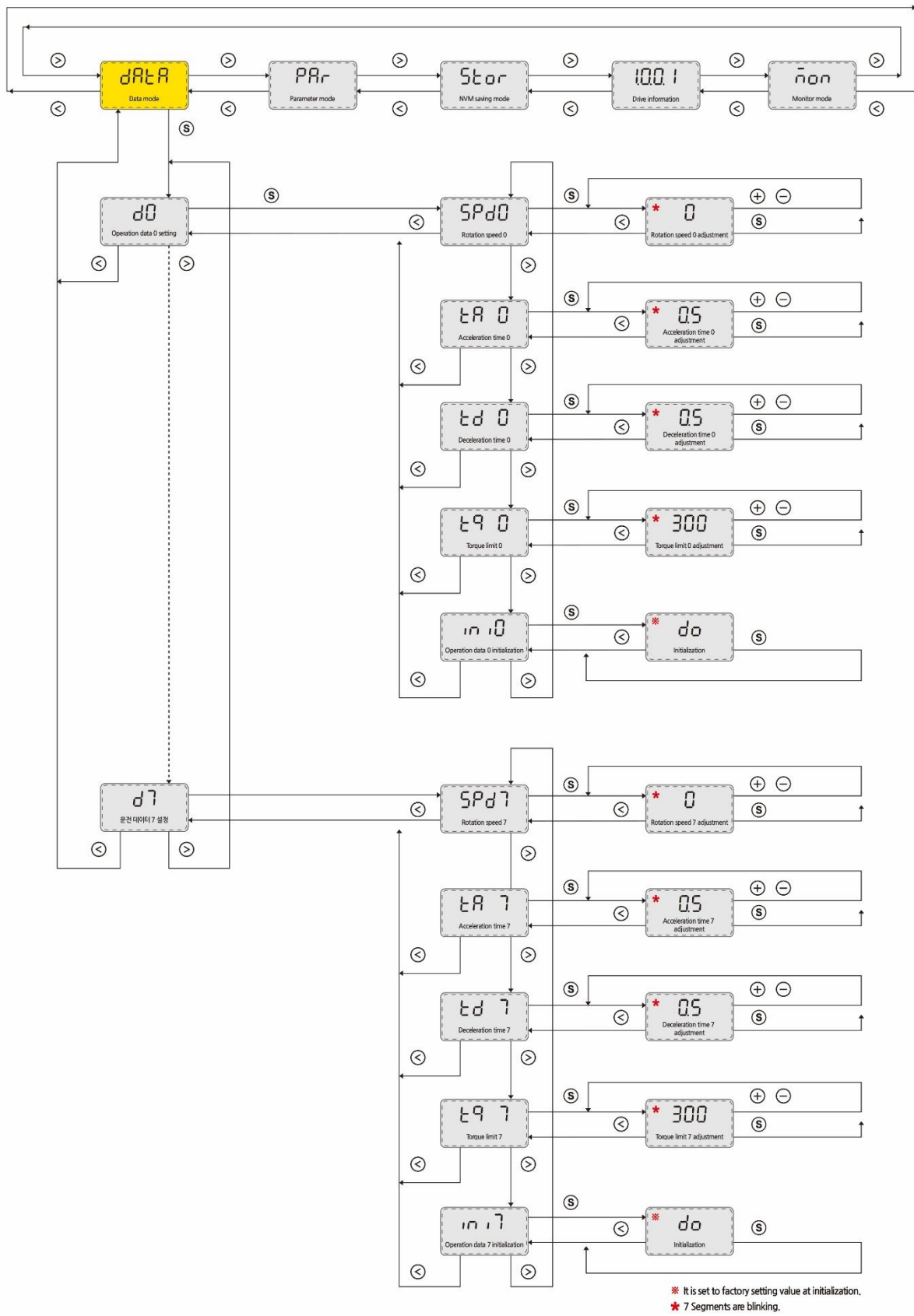

3. Parameter setting mode (1page)

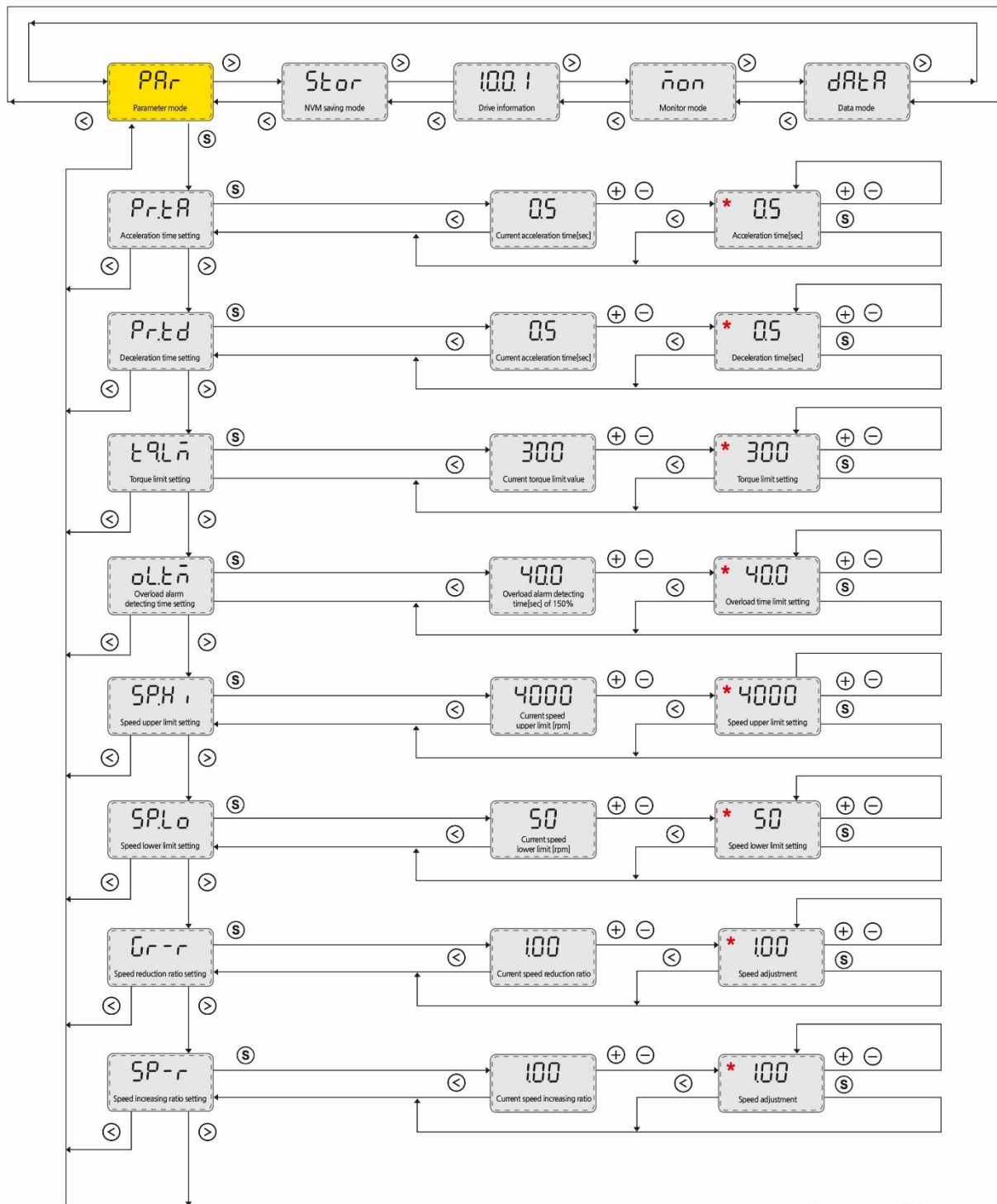

* 7 Segments are blinking.

3. Parameter setting mode (2page)

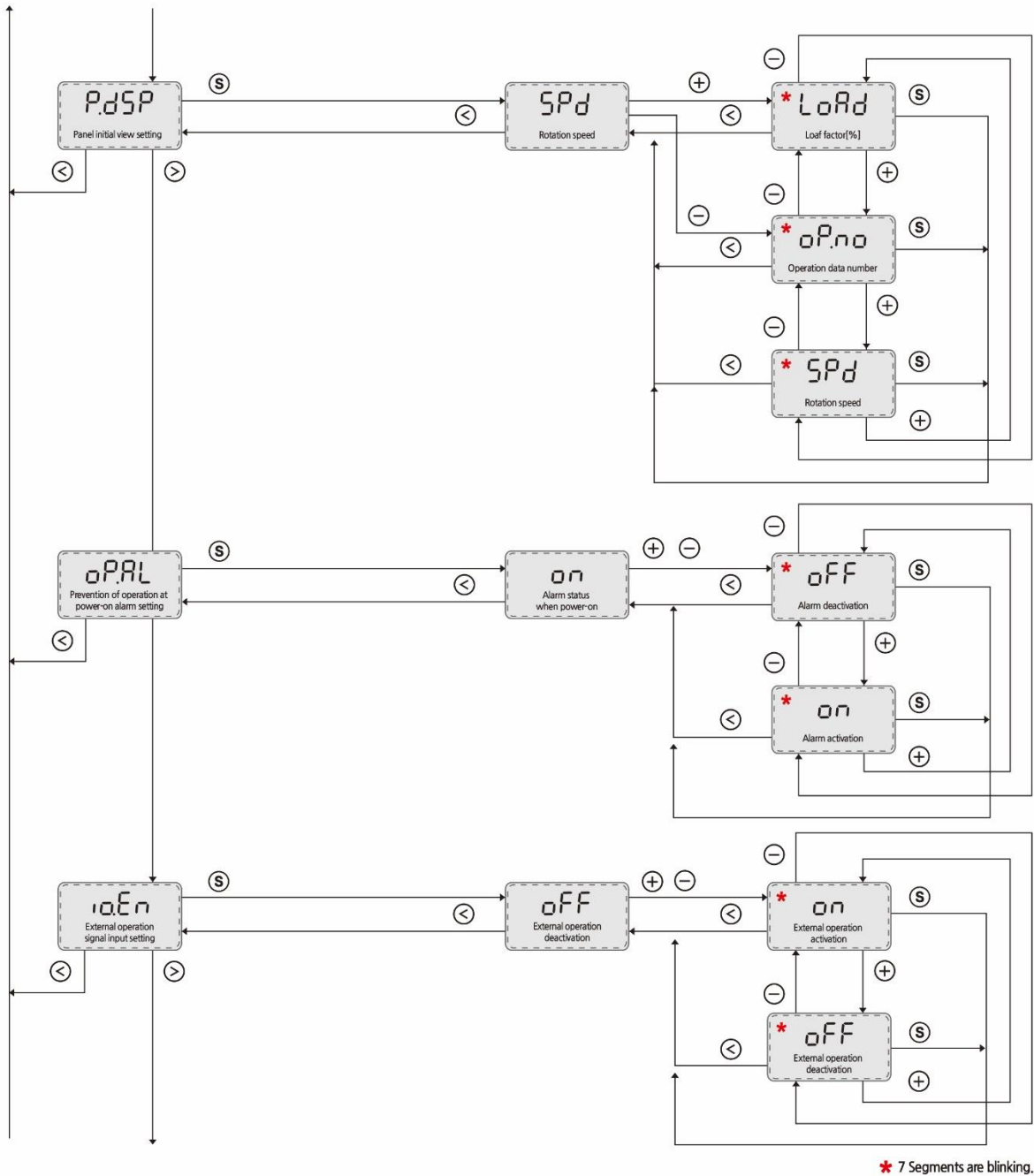

3. Parameter setting mode (3page)

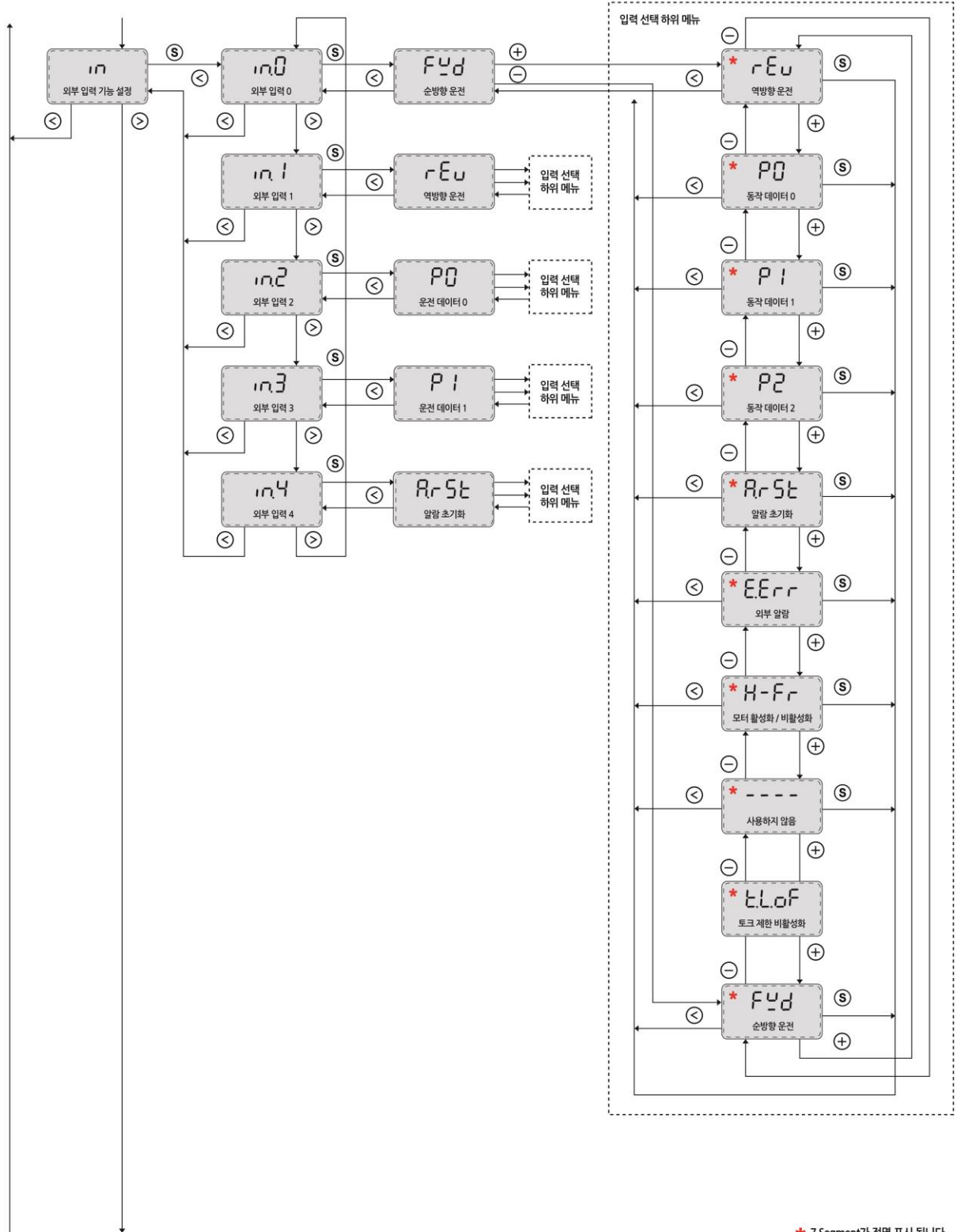

* 7 Segment가 점멸 표시 됩니다.

3. Parameter setting mode (4page)

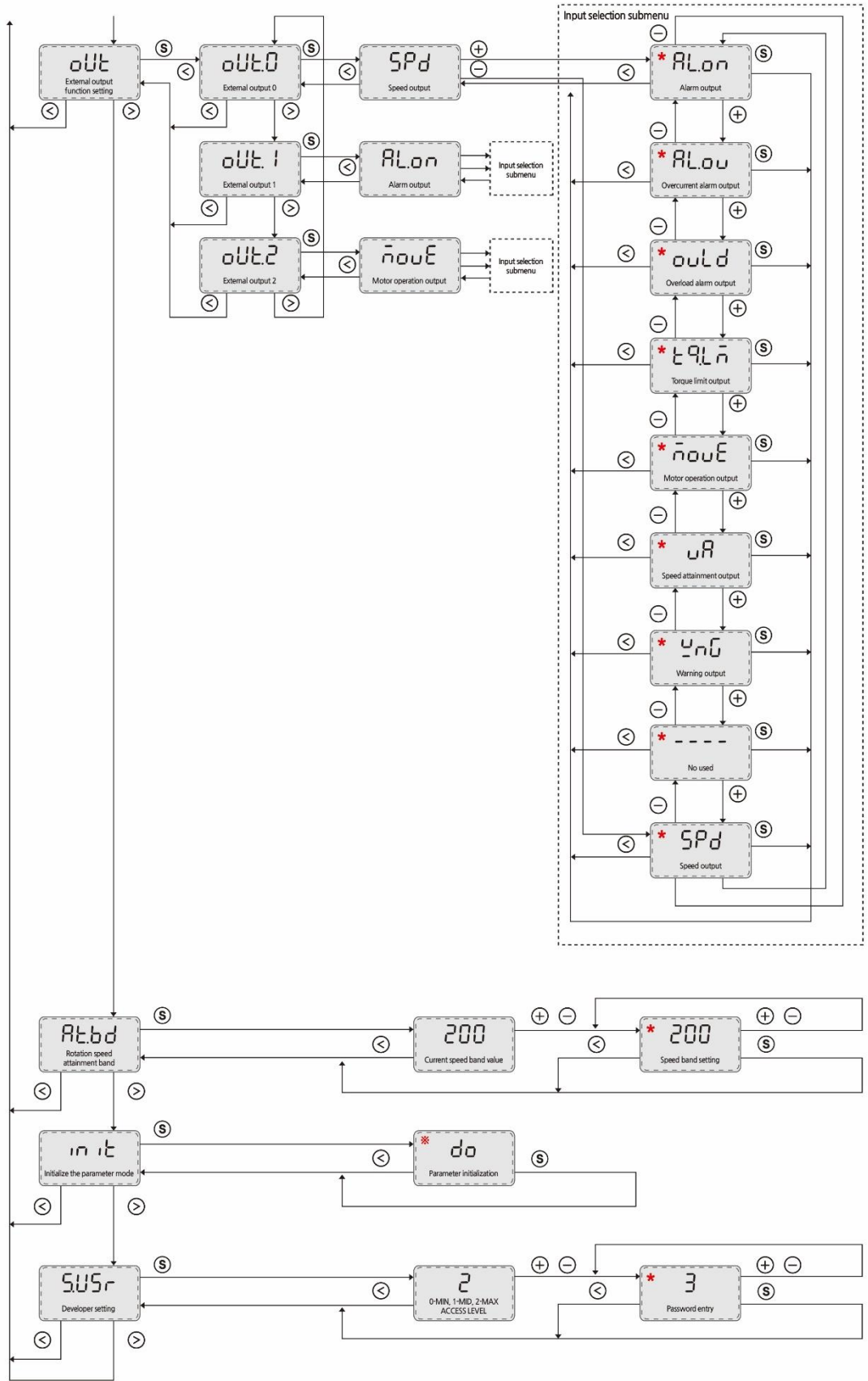

* Restores the value set in the parameter mode to the factory setting
 * 7 Segments are blinking.

4. NVM saving mode

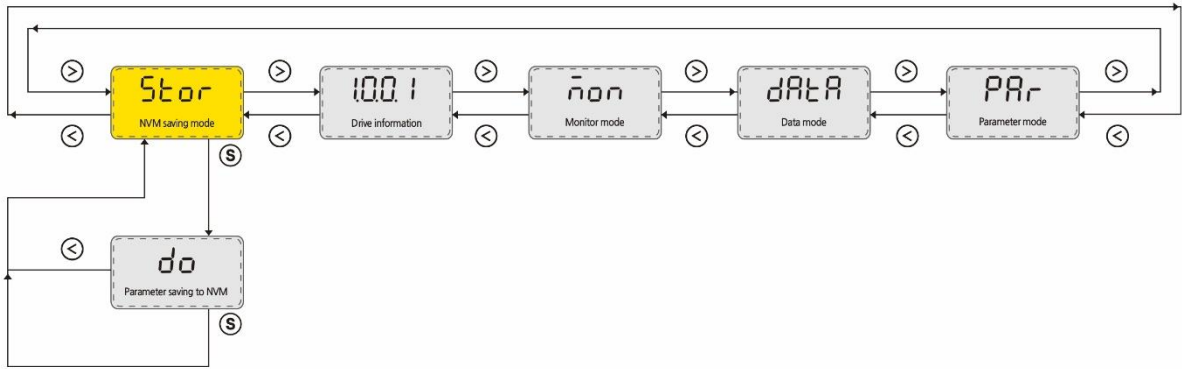

8.3 Parameter list

Item	Display	Description	Setting range	Factory setting
Acceleration time	Pr.tA	Sets the acceleration time	0.0 ~ 15 s	0.5 S
Deceleration time	Pr.td	Sets the deceleration time	0.0 ~ 15 s	0.5 S
Torque limit	Tq.LM	Sets the torque limit	10~300	300
Overload alarm detection time except when holding a shaft	oL.tM	Sets the time to output the alarm after detecting the overload condition when a load up to the limited duty region exceeding the continuous duty region was applied.	0.1 ~ 60 s	40 S
Speed upper limit	SP.Hi	Sets the upper limit of the rotation speed	50 ~ 4000 rpm	4000 rpm
Speed lower limit	SP.Lo	Sets the lower limit of the rotation speed	50 ~ 4000 rpm	50 rpm
Speed reduction ratio	Gr-r	Sets the speed reduction ratio relative to the rotation speed of the motor output shaft. Displays the speed calculated based on the speed reduction ratio on the monitor mode. If the speed reduction ratio for the conveyor is calculated and input, the conveyor speed can also be displayed.	1.00 ~ 9999	1.00
Speed increasing ratio	SP-r	When increasing the motor rotation speed using the external input, the converted speed can be displayed.	1.00 ~ 2.00	1.00
Panel initial display	P.dSP	After the power is turning on, the item displayed on the monitor mode can be changed.	SPd – Rotation speed (r/min) Load – Load factor (%) oP.no – Operation data number	SPd
Prevention of operation at power-on alarm	oP.AL	Sets whether to enable or disable the “prevention of the operation at power on alarm”	on – Enable oFF – Disable	on
External input function	io.En	The operation method can be selected between the front panel and external	oFF – Disable on – Enable	oFF

Item	Display	Description	Setting range	Factory setting
		al input signals. When operating or stopping the motor using the external input signals, the functions of the operation switch, rotation direction switch, and setting button can be set to disable.		
External I/O function	in	External input setting.		
X0 input function selection	in.0	Assigns the input signals to the external input terminals.	Fwd – FWD rEv – REV P0 – Operation data 0 P1 – Operation data 1 P2 – Operation data 2 A.rSt – Alarm reset E.Err – External error t.q.OF – Torque Limit Off ----- Not used	Fwd
X1 input function selection	in.1			rEv
X2 input function selection	in.2			P0
X3 input function selection	in.3			P1
X4 input function selection	in.4			A.rSt
External output function	oUt	External output setting.		
Y0 output function selection	oUt.0	Assigns the output signals to the external output terminals.	SPd – Rotation speed AL.on – Alarm on AL.ov – Overvoltage OvLd – Overload Tq.LM – Torque limit MovE – Motor operation vA – Rotation speed WnG – Warning ----- Not used	SPd
Y1 output function selection	oUt.1			AL.on
Y2 output function selection	oUt.2			MovE
Rotation speed attainment band	At.bd	Sets the band within which the rotation speed of the motor is deemed to have reached the set value.	1 ~ 400 rpm	200 rpm
Initialize the parameter mode	init	Restores the value set in the parameter mode to the factory setting.		Initial value
Developer setting	S.USr	Developer setting	0 – User setting	0

 Attention	<ul style="list-style-type: none"> • When setting the speed increasing ratio to 1.00, the speed reduction ratio will be effective. • When setting a longer time in the "overload alarm detection time except when holding a shaft" parameter, an overload status may continue. Repeating this condition may result in shorter service life of the motor and gearhead. • If a load exceeding the limited duty region was applied or output shaft was holded, the "overload alarm detection time except when holding a shaft" is maximum 5 seconds.
---	--

• Description of I/O signals

Assignment of input functions

Display	Function	Description
[FWd]	FWD	The motor rotates when either FWD input or REV input is set to "ON". The motor instantaneous stop when FWD input and REV input is set to "ON" at the same time.
[rEv]	REV	
[P0]	Operation data 0	These signals are used to select the operation data number. 8 speeds can be specified by using three operation datas.
[P1]	Operation data 1	
[P2]	Operation data 2	
[A.rSt]	Alarm reset	This signal is used to reset the alarm when be operated protection function.
[E.Err]	External error	When turning this signal OFF, an alarm generates and the motor stops instantaneously.
[t.q.OF]	Torque Limit Off	Disable the Torque Limit function (set to default 300%)
[----]	Not used	This input is not assigned to any signal.

Assignment of output functions

Display	Function	Description
[SPd]	Rotation speed	For every rotation of the motor, 30 pulses are output $\text{SPEED [RPM]} = (\text{SPEED-OUT [Hz]} * 60 [\text{Sec}]) / 30 [\text{pulses}]$
[AL.on]	Alarm start	It is output when an alarm is generated (Normally closed)
[AL.ov]	Alarm over	It is output when an alarm is finished (Normally open)

[OvLd]	Overload alarm	It is output when overload alarm is generated or exceeded (Normally closed)
[tq.LM]	Torque limit	It is output when the torque limit is reached.
[MovE]	Motor operation	It is output when motor is operated.
[vA]	Rotation speed attainment output	It is output when the motor rotation speed becomes equal the value set by the rotation speed attainment band parameter.
[WnG]	Warning output	It is output when a warning generates. (The motor will continue to operate.) when the warning is released, it will automatically turn OFF
[-...]	Not used	This input is not assigned to any signal.

8.4 Display on the drive

• Operation Mode : Monitor mode

Item	Display	Description
Setting rotation speed display and speed adjustment[RPM]	100	It is displayed motor rotation speed.
Actual rotation speed[rpm]	0	<ul style="list-style-type: none"> • Monitors the rotation speed of gearhead. • Monitors the rotation speed of the gear output shaft or conveyor speed when the "speed reduction ratio" parameter is set. • When the "speed increasing ratio" parameter is set, the rotation speed being increased by the external mechanism is displayed.
Load factor[%]	L. 0	<p>The motor generating torque can be checked. The present load factor is displayed based on the rated torque being 100%.</p> <p>The display is the load factor on the motor output shaft. It is not for the gearhead output shaft. With combination type product, the permissible torque varies depending on the gear ratio of the gearhead. Use the product so that the load does not exceed the permissible torque of the gearhead output shaft.</p>

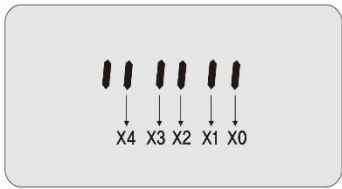
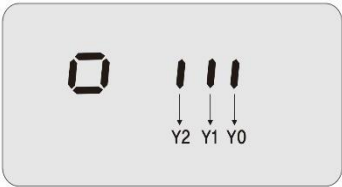
Alarm record and reset	AL.rc	Display alarm record. You can check and reset alarm record.
Warning record and reset	Wn.rc	Display warning record. You can check and reset warning record
Operation data number	oP.d-	Monitors the operation data number currently selected.
I/O status	io	<p>You can check the ON/OFF status of the I.O signal of drive. If the signal is ON, the corresponding digit is lit. if the signal is OFF, the digit is unlit.</p> <p>Input signal</p>  <p>Output signal</p> 

• **Display of the rotation speed**

- **Displayed digit number when setting the speed reduction ratio or speed increasing ratio**

Since the number of significant figures for the integer part is changed if the speed reduction ratio or speed increasing ratio is set, the digit number displayed on the panel will also be changed.

Setting value for the speed reduction ratio and speed increasing ratio	Display on the monitor mode
1.00 ~ 9.99	0 ~ 9999
10.00 ~ 99.99	0.0 ~ 999.9
100.0 ~ 999.9	0.00 ~ 99.99
1000 ~ more	0.000 ~ 9.999

- Display the conveyor speed

To display the conveyor speed, calculate the conveyor speed reduction ratio by using the formula below and set to the "speed reduction ratio" parameter.

$$C_r = \frac{1}{F} = \frac{G_r}{D \times \pi}$$

Conveyor speed reduction ratio	: C_r
Gearhead reduction ratio	: G_r
Feed rate per motor revolution	: F
Pully diameter	: D[m]
Conveyor speed	: C_s [m/min]
Motor output shaft rotation speed	: M_s [r/min]

When the calculated conveyor speed reduction ratio is used, the conveyor speed is converted as follows.

$$C_s = \frac{M_s}{G_r}$$

Example : the pully diameter is 0.2m and gear ratio of the gearhead is 50

$$C_r = \frac{G_r}{D \times \pi} = \frac{50}{0.2 \times \pi} = 79.6$$

From the conversion formula, the conveyor speed reduction ratio is calculated as 79.6 in this example.

Setting the calculated as 79.6 with "speed reduction ratio" and the motor rotation speed is 3000r/min, the conveyor speed is converted as follows:

$$C_s = \frac{3000}{79.6} = 37.7$$

Accordingly, "37.7" is shown on the panel.

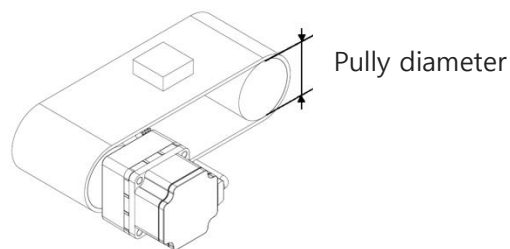

8.5 Setting the operation data

8 types of operation data can be set in this product.

Operate by selecting the operation data number using the P0, P1 and P2 input signals.

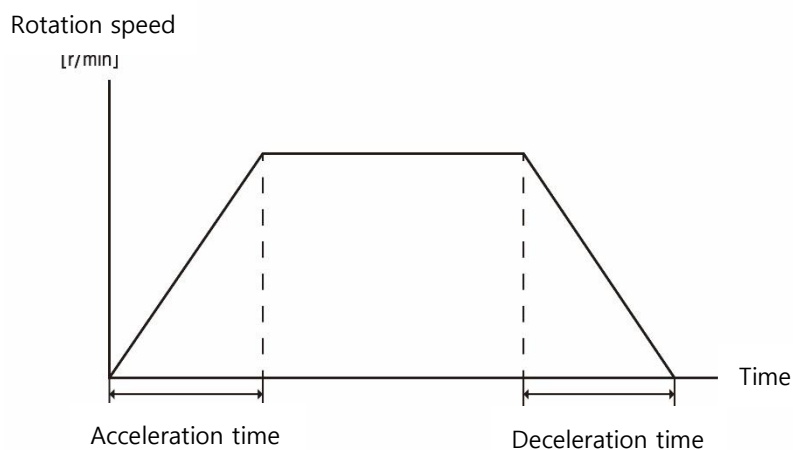

Operation mode : Data mode

Item		Display	Setting range	Factory setting
Operation data number 0~7	Rotation speed	sPd0 ~ sPd7	50 ~ 4000 r/min	100
	Acceleration time	tA0 ~ tA7	0.0 ~ 15.0 sec	0.5
	Deceleration time	td0 ~ td7		
	Torque limit	tq0 ~ tq7	10~ 300 %	300
	Initialize	Ini0 ~ ini7	Restores the operation data to the factory setting. Initialize each operation data number.	-

Refer to the next page for detail about the acceleration time and deceleration time.

8.6 Setting the acceleration time and deceleration time

The acceleration time and deceleration time can be set so that an impact is not applied to a load when the motor is started or stopped.

- Setting the acceleration time and deceleration time

Setting range : 0.0 ~ 15.0 sec (Factory setting : 0.5 sec)

- **Setting to the parameter**

The acceleration time and deceleration time can be set in the parameter in normal operation without operation data.

- **Setting to the operation data**

If you want to set the acceleration time and deceleration time of each data in data mode, you can set it in data mode.

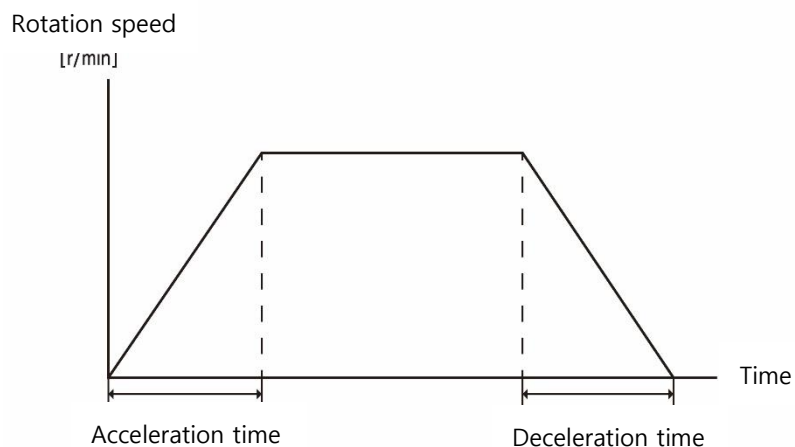

- **Setting of deceleration time "0 sec"**

If you set the deceleration time to a smaller value than the rotation speed and load, "AL.Ov" alarm will be generated. But if the deceleration time is set to 0 seconds, it will not be decelerated but will stop in the "E.BRAKE" status without generating an alarm.

• Motor operation

If the acceleration time and deceleration time are set shorter than 0.5 seconds, the motor takes for a longer time than setting time. If they are setting approximately 0.5 seconds or more, the motor can accelerate and decelerate in the setting time. (With no load)

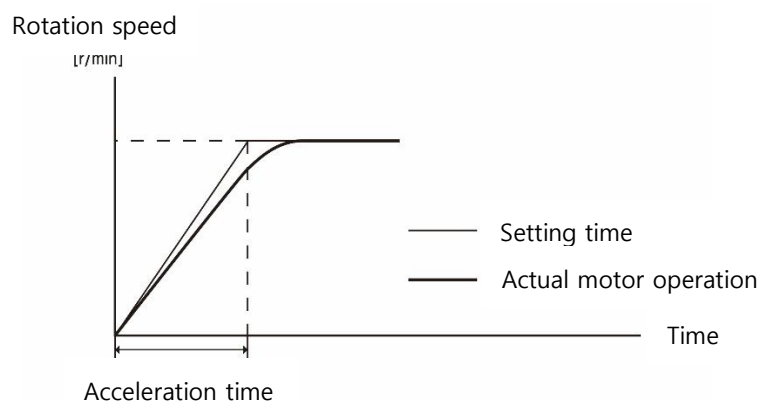

8.7 Setting of torque limit

Torque limit can be set via parameters. Factory setting is 300% and can be set from 10% to 300%

8.8 Lock of setting data

Press and hold the "S" button, can be lock of setting data. If the setting data is locked, the data can not be changed until the lock is released.

8.9 Limiting the setting range of the rotation speed

The setting range of the rotation speed is set to 50 to 4000rpm at the time of shipment. This setting range can be changed to limit

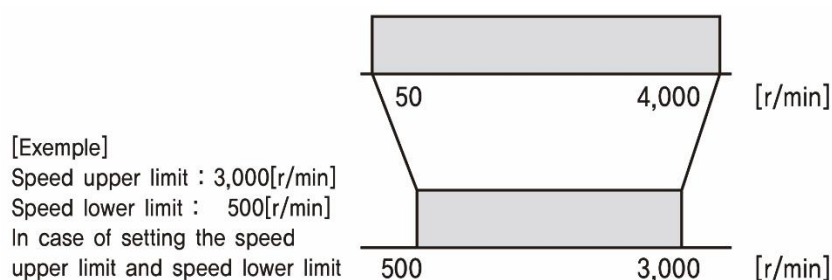

- **Speed upper limit**

Set the upper limit value of the rotation speed in the "speed upper limit" of the "speed upper limit and lower limit" parameter. The rotation speed exceeding the "speed upper limit" cannot be set in the rotation speed of the operation data. If the rotation speed exceeding the "speed upper limit" is already set in the operation data, the rotation data set in the "speed upper limit" will be overwritten.

- **Speed lower limit**

Set the lower limit value of the rotation speed in the "speed lower limit" of the "speed upper limit and lower limit" parameter. The rotation speed lower than the "speed lower limit" cannot be set in the rotation speed of the operation data. If the rotation speed lower than the "speed lower limit" is already set in the operation data, the rotation data set in the "speed lower limit" will be overwritten.

9. System diagram

9.1 System diagram

- 30W, 60W, 120W (110V)

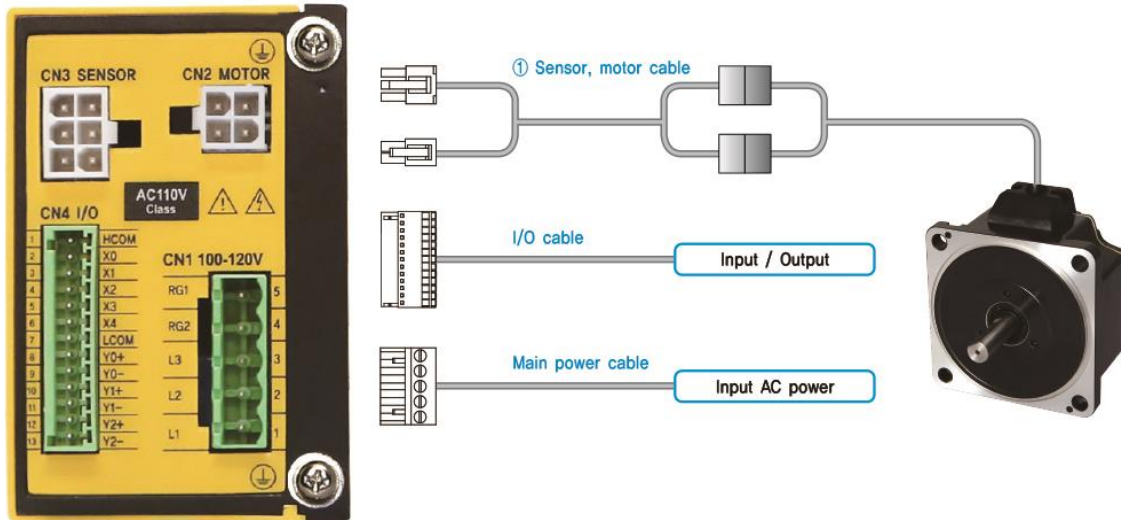

30W, 60W and 120W motors have one line with motor relay cable and sensor relay cable.

- 30W, 60W, 120W (220V)

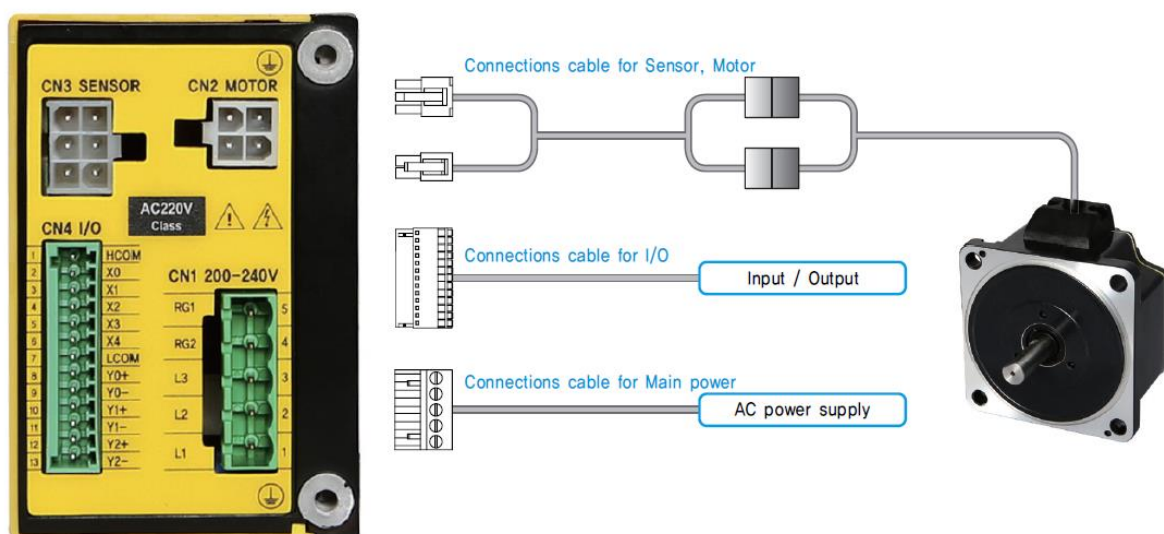

30W, 60W and 120W motors have one line with motor relay cable and sensor relay cable.

- 200W, 400W (220V)

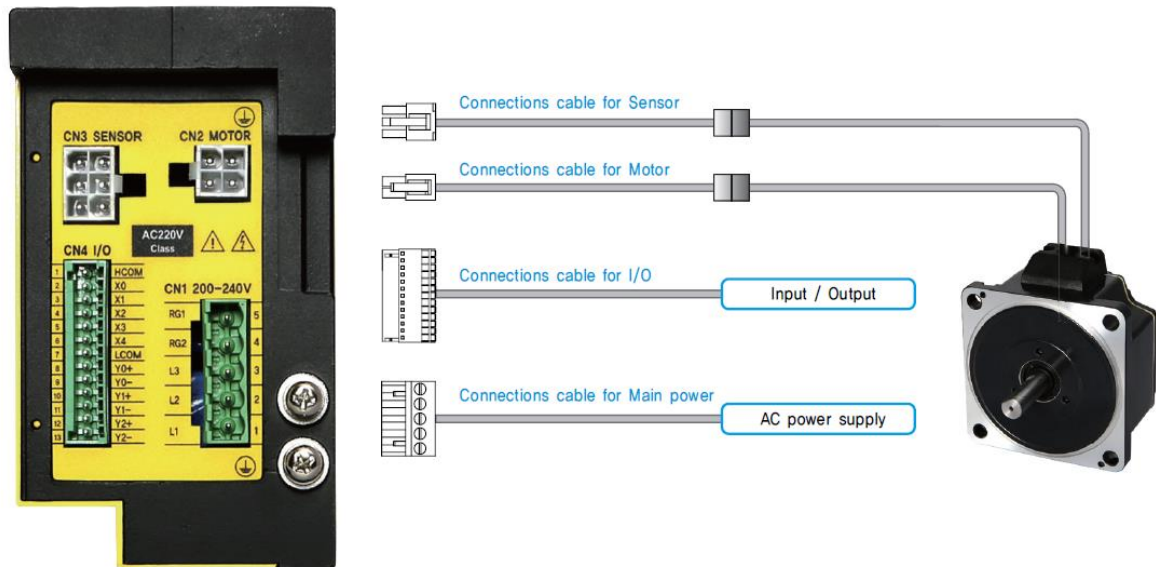

200W and 400W motors have two lines with motor relay cable and sensor relay cable.

10. Troubleshooting and remedial actions.

10.1 Alarm

If a protective function is activated and an alarm is generated, the motor will "E.STOP" and motor shaft is free status. At the same time, the alarm code is displayed. The alarm type can be checked by the alarm code.

 Attention	<ul style="list-style-type: none"> • Cycle the power to reset the overcurrent and EEPROM(Electrically Erasable Programmable Read-only Memory) error alarms. When cycling the power, turn off power and wait for minimum 1 minute before doing so. If the product can not operate properly after the power is cycled, the internal circuit may be damaged. Contact your nearest sale office. • The motor stops instantaneously at the time of external stop(At.Et). After the motor is stopped, the motor shaft is free status.
---	--

• Alarm list

Alarm code	Alarm type	Cause	Remedial action	Alarm reset
[AL.--]	Alarm recode delete	-	-	-
[AL.UV.]	Under voltage	The power supply voltage became lower than approximately 60% of the rated voltage	1. Check the power supply voltage 2. Check the wiring of the power supply cable	Possible
[AL.OV.]	Over voltage	1. The power supply voltage exceeded approximately 120% of the rated voltage. 2. Vertical drive (gravitational operation) was performed or a load exceeding the permissible load inertia was driven.	1. Check the power supply voltage 2. If this alarm occurs during operation, reduce the load or make the acceleration/deceleration time longer. .	Possible
[AL.OT.]	Overheat	The temperature inside drive	Review the ambient temperature.	Possible

Alarm code	Alarm type	Cause	Remedial action	Alarm reset
		exceeded the alarm detection temperature.		
[AL.OC]	Overcurrent	Excessive current has flown through the drive due to ground fault. Etc.	Check the wiring between the drive and motor for damage.	Not Possible
[AL.ST]	Start	-	-	-
[AL.SF]	Speed feedback	Actual speed and set speed are different.	1. Check the power supply voltage. 2. Check the load.	Possible
[AL.SS]	Sensor error (Hall sensor)	The motor sensor signal line experienced an open circuit during operation or the motor signal connector came off.	Check the wiring between the drive and motor.	Possible
[AL.OS]	Overspeed	The rotation speed of the motor output shaft exceeded approximately 4800rpm		Possible
[AL.OL]	Overload	1. A load exceeding the continuous duty region was applied to the motor for the time exceeded the value set in the "The overload alarm detection time" parameter. 2. The motor was started running under the state that the motor temperature was low.	1. Reduce the load 2. Review the operation pattern such as acceleration/deceleration time.	Possible
[AL.oP]	Operation at power-on	When the "external operation signal input" parameter was set to "OFF", while the operation switch was set to the "RUN" side, the power was turned on again.	Set the operation switch to the "STAND-BY" side from the "RUN" side. Next press "S" button.	Possible
		When the "external operation signal input" parameter was set to "ON", while the FWD input or REV input was turned ON, the power was turned on again.	1. Set the operation switch to the "STAND-BY" side from the "RUN" side. 2. Turn the FWD input or REV input from ON to OFF.	
[AL.Et]	External Error (From external input signal)	The motor instantaneous stop when EXT-ERROR (Stop) input.	1. Check the EXT-ERROR input. 2. Change status from activated to deactivated	Possible

- **Alarm reset**

Always reset an alarm after ensuring safety by removing the cause of the alarm and turning the operation signal OFF.

- **Alarm release**

Always release an alarm after ensuring safety by removing the cause of the alarm and turning the operation signal OFF.

- **Alarm release method**

- After the operation switch is set to "STAND-BY", it can be released by pressing the "S" button.
- Turn off the power, wait for at least 1 minute, and then cycle the power.

 Attention	<ul style="list-style-type: none"> • If the product dose not operate properly after the power is cycled, the internal circuit may be damaged. Contact your nearest sale office. • Continuing the operation without removing the cause of the alarm may cause malfunction of the equipment.
---	--

- **Reset using the ALARM-RESET input**

Turn the operation signal OFF and then turn ALARM-RESET input ON (Keep it ON for 10 msec or more). The ALARM-RESET input is disabled while the operation signal is being ON. The figure shows an example for which the operation signal is the FWD input.

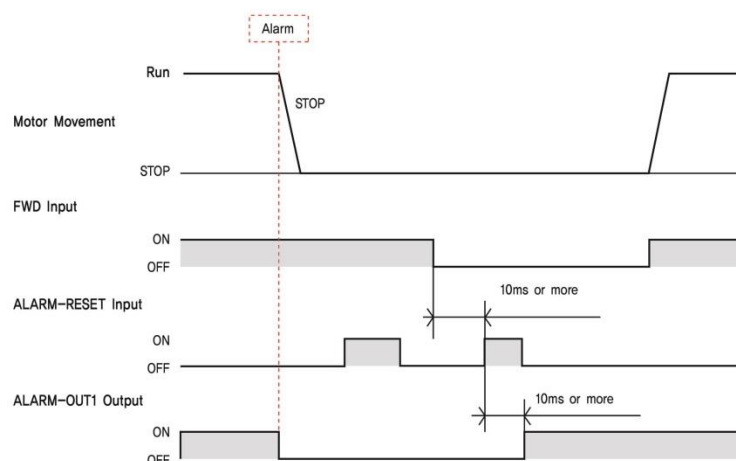

- **Alarm records**

Up to 10 generate alarms to save in NVM (Non-volatile memory) in order of the latest to oldest. When clearing the alarm records, perform the alarm record clear on the monitor mode.



Attention

- Do not turn off the drive power while an alarm records are being cleared (while the display is blinking). Doing so may damage the data.

10.2 Warning

The warning type and code are displayed.

When a warning generates, WNG output turns ON. WNG output of the output terminal is not allocated at the factory setting.

• Warning list

Display	Description
[Wn.--]	Not warning or warning record
[Wn.OL]	Warning - Overload
[Wn.oP]	Warning – Problem when the power turn on

• Warning records

Up to 10 generated warnings are saved in the RAM in order of the latest to oldest.

When clearing the warning records, perform the warning record clear on the monitor mode.



Attention

- The warning records will be cleared by turning off the drive power.

10.3 Troubleshooting and remedial actions

During motor operation, the motor or drive may fail to function properly due to an improper speed setting or wiring.

When the motor cannot be operated correctly, refer to the contents provided in this section and take appropriate action. If you cannot operate normally after the appropriate action, contact your dealer or head office.



Attention

- Check the alarm message when the alarm generates.
- I/O signals can be monitored with monitor mode. Use to check the wiring condition of the I/O signals.

Phenomenon	Possible cause	Remedial action
The motor doesn't operate.	The power supply is not connected correctly or is has become improper connection.	Check the connection s between the drive and power supply.
	The operation switch is set to the "STAND-BY" side.	Set the operation switch to the "RUN" side.
	When operating the motor using external signals, the "external operation signal input" parameter is set to "OFF"	Set the "external operation signal input" parameter to "OFF" after turning the input operation signal OFF.
	<ul style="list-style-type: none"> • Both the FWD input and REV input are being OFF. • Both the FWD input and REV input are being ON. 	Turn either of the FWD input or REV input ON.
	An alarm is present.	A protective function is triggered and an alarm generates. Refer to "10.1 Alarm" and reset the alarm after removing the cause of the alarm.
The rotation speed is not displayed.	The "panel initial view" parameter is not set to the rotation speed.	Set the "panel initial view" parameter to the rotation speed.
The motor rotates in the direction oppsite to the specified direction	The FWD input and REV input are connected wrongly or otherwise not connected correctly.	Check the connection of the FWD inpur and REV input.
	1. The combination type parallel shaft gearhead using a gear with gear ratio of 30, 50 and 100. (30W, 60W, 120W motors) 2. The combination type parallel	When the rear ratio of the combination type parallel shaft gearhead is 30, 50, and 100(For 30W, 60W and 120W motors) and 30, 50(For 200W, 400W

<p>The rotation speed cannot be increased.</p> <p>The rotation speed cannot be decreased.</p> <p>Motor operation is unstable.</p>	shaft gearhead using a gear with gear ratio of 30 or 50 (200W, 400W motors)	motors), the rotating direction of the gear output shaft is opposite of the motor output shaft. Accordingly, reverse the FWD input and REV input operations.
	The rotation direction switch is set wrong.	Check the rotation direction switch.
	The speed upper limit has been set	Raise the value of speed upper limit parameter. Maximum speed upper value is 4000rpm.
	The speed lower limit has been set	Lower the value of speed lower limit parameter. Maximum speed lower value is 50rpm.
	The motor (gearhead) output shaft is not misaligned with the load shaft.	Check the coupling condition for The motor (gearhead) output shaft and load shaft.
Motor vibration is too big.	Effect of electrical noise from external device.	<ul style="list-style-type: none"> - Check the operation only with the motor, drive and other external equipment required for operation. If an effect of noise has been confirmed, implement the following countermeasures. - Move the unit farther away from the noise generation sources. - Reviewing the wiring. - Change the signal cables to a shielded type. - Install ferrite cores.

10.4 Regular inspection

It is recommended to periodically inspect the following items list after each operation of the motor.

 Attention	<ul style="list-style-type: none"> • When connected motor and drive, do not the insulation resistance test or dielectric strength test. It may result in damage to the product. • The drive uses semiconductor elements, so be careful when handing them. Electrostatic discharge can damage the drive.
---	---

• Inspection item

No	Inspection item	Action
1	Are any of the motor (gearhead) mounting screws loose?	Tighten the screws.
2	Are there any abnormal noises in the motor ball bearing or other parts?	Stop using the product immediately, contact to the technical support center.
3	Are there any abnormal noises in the ball bearing or meshing parts of the gearhead?	
4	Is the motor output shaft and load shaft out of alignment?	
5	Are there any scratches, problem or loose drive connections in the cable?	
6	Are there an abnormal odor or problem inside the drive?	Tighten the screws.
7	Are any of the mounting screws or main power input unit of the drive loose?	
8	Are there any foreign substance in the mechanical part of the drive?	Using the product after remove the foreign substance.

11. Option (Sold separately)

• Connection cable

This cable is used to extend the wiring distance between the motor and drive. The wiring distance between the motor and drive can be extended to a maximum of 10.5m.

Length [m]	Part Number (30W, 60W, 120W)	Part Number (200W, 400W)	
		Motor cable	Sensor cable
1	CSPD-A-001F	CSPD-M-001F	CSPD-S-001F
2	CSPD-A-002F	CSPD-M-002F	CSPD-S-002F
3	CSPD-A-003F	CSPD-M-003F	CSPD-S-003F
5	CSPD-A-005F	CSPD-M-005F	CSPD-S-005F
7	CSPD-A-007F	CSPD-M-007F	CSPD-S-007F
10	CSPD-A-010F	CSPD-M-010F	CSPD-S-010F

-Wiring Diagram

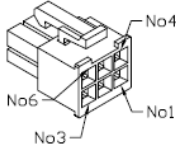
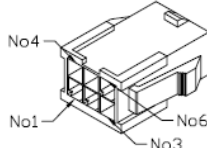
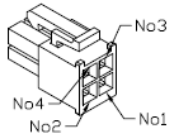
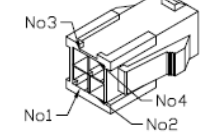
Connector of drive side		Connection	Connector of motor side	
Pin plan	Pin number		Pin plan	Pin number
	1	—————	1	
	2	—————	2	
	3	—————	3	
	4	—————	4	
	5	—————	5	
	6	—————	6	
	1	—————	1	
	2	—————	2	
	3	—————	3	
	4	—————	4	

Sensor connector side is shielded cable.

- Connector specification

Purpose		ITEM	Specification	Manufacturer
Connector of drive side	Sensor connector	Housing Terminal	5557-06R 5556T	MOLEX MOLEX
	Motor connector	Housing Terminal	5557-04R 5556T	MOLEX MOLEX
Connector of motor side	Sensor connector	Housing Terminal	5559-06P 5558T	MOLEX MOLEX
	Motor connector	Housing Terminal	5559-04P 5558T	MOLEX MOLEX

• **Pin plan of motor cable**

It is the pin plan of motor cable from motor side

- **Pin plan of motor connector**

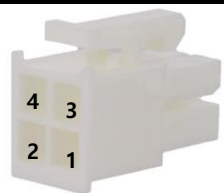
No	Color	Function	Pin plan			
1	-	-				
2	BLUE	BLDC_U				
3	GRAY	BLDC_W				
4	PURPLE	BLDC_V				
			Purpose	ITEM	Specification	Manufacturer
			Motor side	Housing	5557-04R	MOLEX
			Motor side	Terminal	5556T	MOLEX

- **Pin plan of sensor connector**

No	Color	Function	Pin plan			
1	YELLOW	+5V_E				
2	BLOCK	Shield				
3	GREEN	GND_E				
4	BROWN	HALL_U				
5	WHITE	HALL_V				
6	ORANGE	HALL_W				
			Purpose	ITEM	Specification	Manufacturer
			Motor side	Housing	5557-06R	MOLEX
			Motor side	Terminal	5556T	MOLEX

• **Pin plan of I/O signal connector**

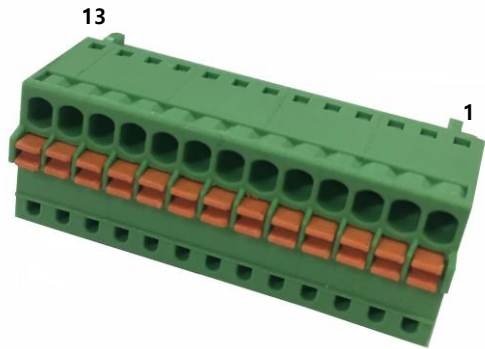
No	Color	I/O	Pin plan			
1	HCOM	Common				
2	X0	Input				
3	X1	Input				
4	X2	Input				
5	X3	Input				
6	X4	Input				
7	LCOM	Common				
8	Y0+	Output				
9	Y0-	Output				
10	Y1+	Output				
11	Y1-	Output				
12	Y2+	Output				
13	Y2-	Output				
			Purpose	ITEM	Specification	Manufacturer
			Controller side	Housing	15EDGKD-13P	DEGSON

12. Reference

12.1 CE marking

Ezi-SPEED is implemented the CE marking under Low Voltage Directive and EMC Directive. The part number of the certification product is motor part number and drive part number.

• Low Voltage Directive

- This product cannot be used with cable normally used for IT equipment.
- Do not touch the hands after installing the product
- Be sure to ground the protective earth terminal of the motor and drive
- Motor cable and power supply cable should be separated by double insulation.
- Applicable Standard
 - Motor : EN 60034-1:2004
 - Driver : EN 61800-5-1:2007

• EMC Directive

The EMC Directive will vary depending on the control system equipment used with the other control system equipment, configuration of electrical parts, wiring, layout, hazard level, and the like. You must be verified through conducting EMC measures on your mechanical equipment.

- Applicable Standard

EMI	Conduction noise, Radiated noise, Noise power, Antenna terminal voltage, High frequency output terminal voltage, Harmonic, Flicker	EN 61800-3:2004 + A1:2012 EN 61000-3-2:2014 EN 61000-3-3:2013
EMS	Electrostatic Discharge Immunity , Radiated RF-Electromagnetic Field Immunity , Electrical Fast Transient / Burst Immunity , Surge Immunity Conducted RF Field Immunity Power-Frequency Magnetic Field Immunity , Voltage Dips, Short Interruptions and Voltage variation Immunity	EN 61800-3:2004

• Toxic substance

Ezi-SPEED does not contain toxic substances exceeding the limits of the RoHS Directive.

12.2 Installing and wiring method in compliance EMC Directive

This product has been designed and manufactured to be incorporated in equipment. The EMC Directive requires that your mechanical equipment in which the product is satisfies the applicable requirements. The final level of conformance of your mechanical equipment to the EMC Directive will vary depending on the control system equipment used with the other control system with motor, configuration of electrical parts, wiring, layout, hazard level, and the like. You must be verified through conducting EMC measures on your mechanical equipment.

• **Connecting an AC Line Filter**

Install an AC line filter which the customer provides, in the power line in order to prevent the noise generated within the drive from propagating outside via the AC input line. For AC line filters, use the products as shown in the below, or an equivalent.

Single-phase 100-120V, 200-240V : 6EMC1 F8127(Corcom), NAC-06-472(Cosel)

Three-phase 200-240V : TAC-06-683(Cosel)

- Install the AC Line Filter as close to drive as possible.
- Use cable clamps and other means to secure the input and output cables firmly to the surface of the enclosure.
- Connect the ground terminal of the AC Line Filter to the grounding point, using as thick and short a wire as possible.
- Do not place the AC input cable parallel with the AC line Filter output cable. Parallel placement will reduce AC line Filter effectiveness if the enclosure's internal noise is directly coupled to the power supply cable by means of stray capacitance.

• **Note about insulating and wiring**

Connect the motor/drive and other peripheral control equipment directly to the grounding point so as to prevent a potential difference from developing between grounds.

Wire cable as short as possible.

Wire the power lines such as the motor cable and power cable away from the signal cable by providing a minimum clearance of 100mm between them. If they must cross, do so at a right angle. Palce AC input cable and output cable of the AC line Filter separately from each other. Use a connection cable of option when extending the wiring distance between the motor and drive. The EMC measures are conducted using the FASTECH connection cable.

- **Precautions about static electricity**

Static electricity may cause the drive to malfunction or suffer damaged.

Be sure to ground the product to prevent it from being damaged by static electricity.

Expect when operating the setting button or switch on the drive front panel, do not come to close or touch the drive while the drive power ON.

- It is prohibited to copyright or replication of the part or whole of user manual without permission.
- When user manual is needed due to damage or loss, please contact Head Quarter of Fastech or our distributors.
- The user manual can be changed without pre-notification in order to reflect improvement or change of the product specifications and for the improvement of user manual.
- Ezi-SPEED is registered trademark of FASTECH Co., Ltd. which is registered in Korea.



Fast, Accurate, Smooth Motion

FASTECH Co., Ltd.

Rm#1202, 401-dong, Bucheon Techno-Park,
655, Pyeongcheon-ro, Bucheon-si Gyeonggi-do
Republic of Korea (Postal Code: 14502)

TEL : +82-32-234-6300 **FAX** : +82-32-234-6302

E-mail : sales@fastech-motions.com

Homepage : www.fastech-motions.com

© Copyright FASTECH CO., LTD. 2018