

Ezi-IO[®]

Input/Output Module

- Ethernet Based Digital I/O Module
- Plus-E Series Communication Protocol Supported
- Simple and Easy Wiring

Ethernet
DIO

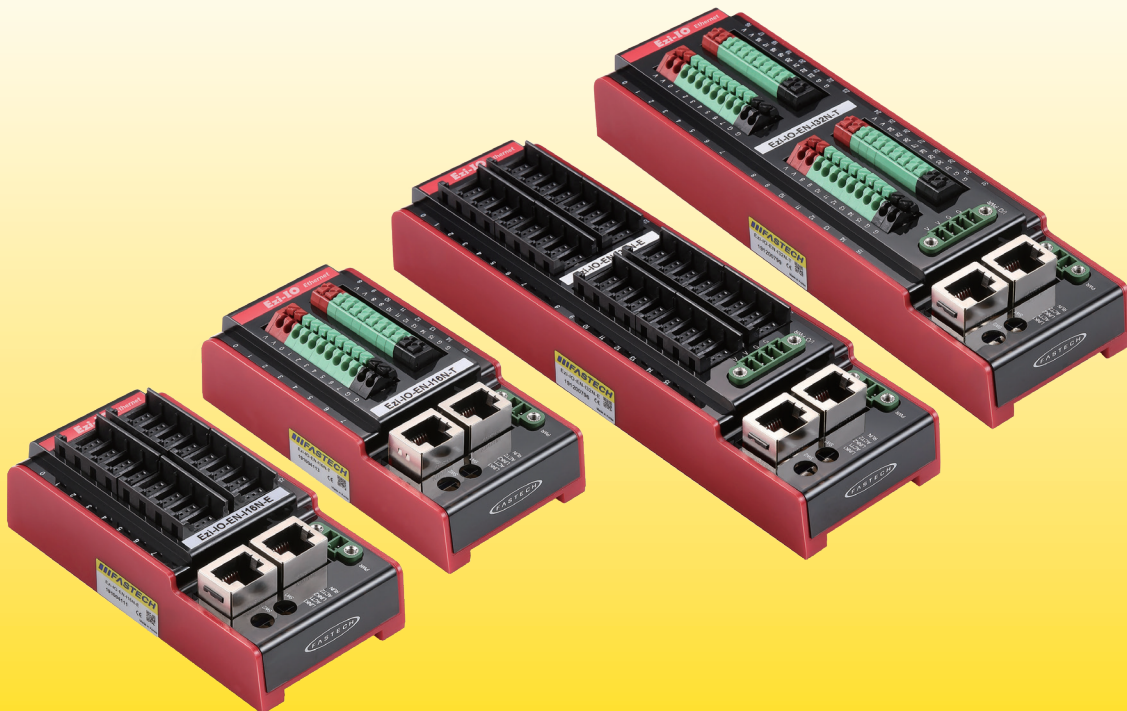

CE

FASTTECH

Fast, Accurate, Smooth Motion

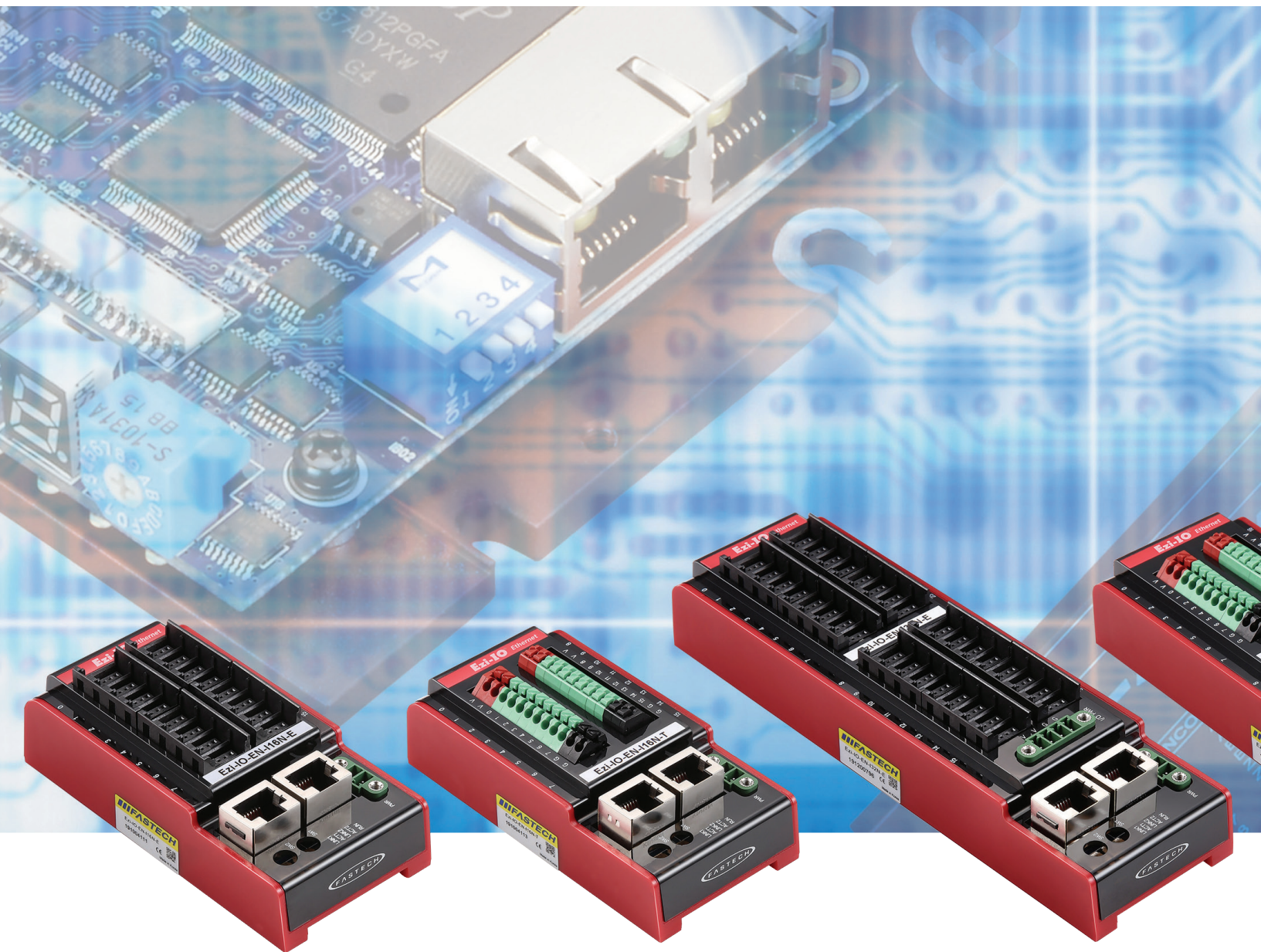

FASTECH

Fast, Accurate, Smooth Motion

Ezi-IO[®] **Ethernet**
Input/Output Module **DIO**

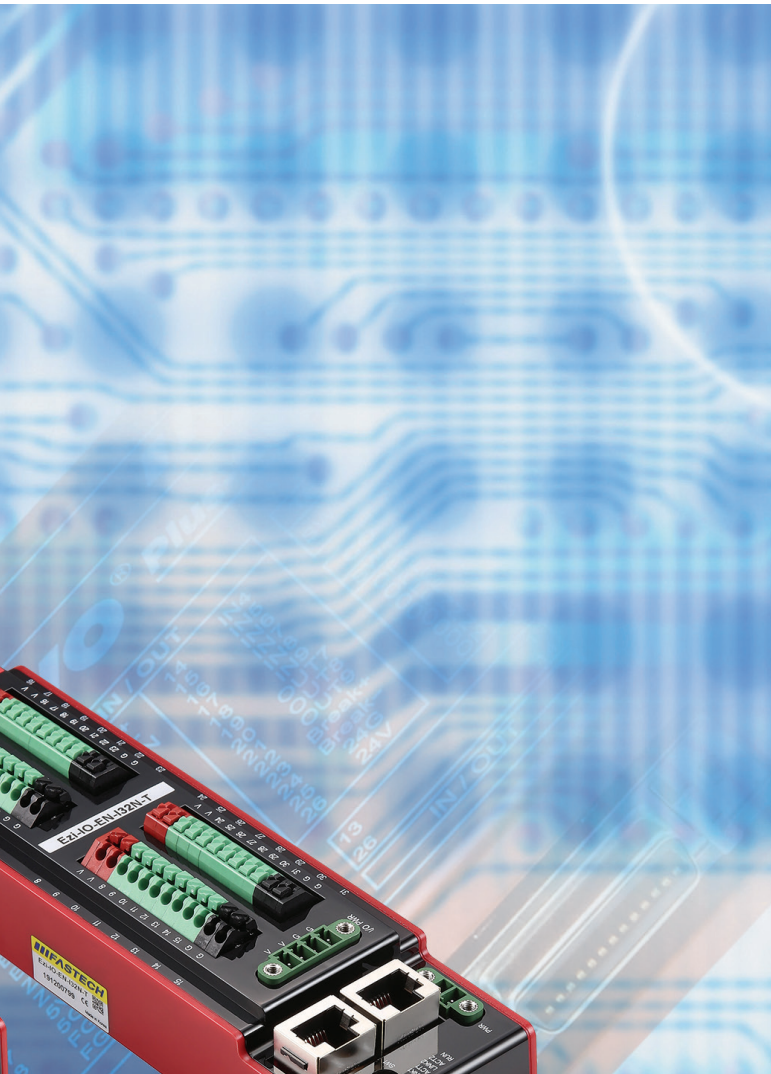

1 Ethernet Based Digital I/O Module

Ezi-I/O Ethernet DIO is a digital I/O module controlled with Ethernet. Since it uses the same communication protocol as FASTECH's other Ethernet products, it can be applied very easily to the customers who have experiences using FASTECH's Ethernet products. Motion Library(API) is provided for programming under Windows 7/8/10.

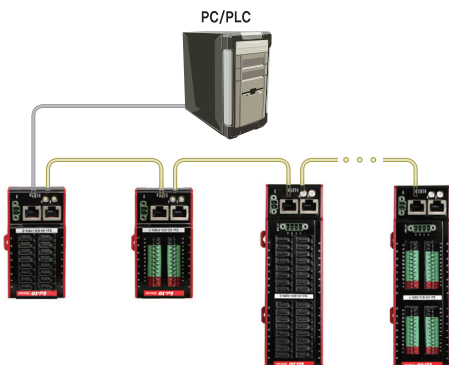

2 GUI(Graphic User Interface) Program

You can easily monitor I/O status or set input signal level of Ezi-I/O Ethernet DIO with GUI (Graphical User Interface) software provided by FASTECH.

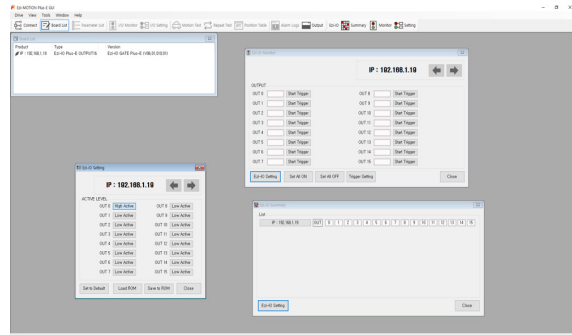

3 Various I/O Module

Ezi-I/O Ethernet DIO provides 16CH and 32CH modules. There are 16CH DC input module, 16CH transistor output module, and 8CH DC input/8CH transistor output mixed module for 16CH type products. In addition, there are 32CH DC input module, 32CH transistor output module, 16CH DC input/16CH transistor output mixed module for 32CH type products. Also, Ezi-I/O Ethernet DIO provides NPN/PNP compatible modules to support various I/O devices.

4 Advanced Functions for I/O Signal Processing

The input module can detect and count very fast signals by using the latch function and the latch count function. The output module can use the trigger output function to set the signal output conditions according to the purpose.

Ezi-IO Ethernet DIO Part Numbering

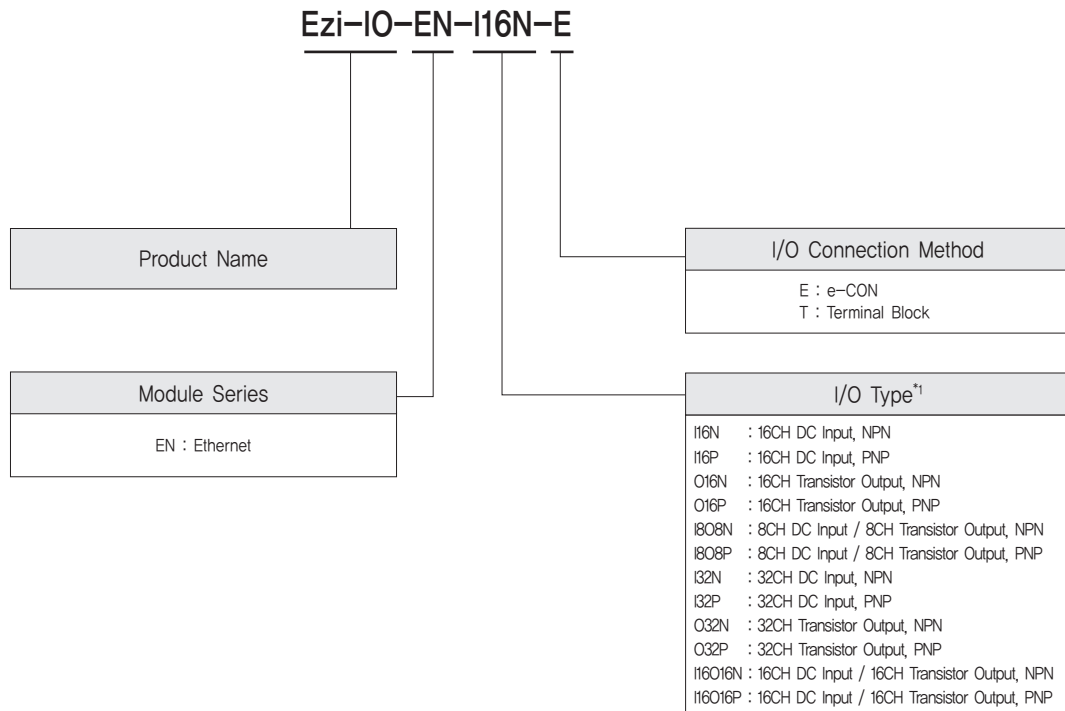

*1: NPN and PNP are classified as follows according to I/O type.

DC Input	NPN	Positive Common Type
	PNP	Negative Common Type
Transistor Output	NPN	Sink Output
	PNP	Source Output

Ezi-IO Ethernet DIO Part Number

Part Number	Remarks	Part Number	Remarks
Ezi-IO-EN-I16N-E	16CH e-CON Type	Ezi-IO-EN-I32N-E	32CH e-CON Type
Ezi-IO-EN-I16P-E			
Ezi-IO-EN-O16N-E			
Ezi-IO-EN-O16P-E			
Ezi-IO-EN-I8O8N-E			
Ezi-IO-EN-I8O8P-E			
Ezi-IO-EN-I16N-T	16CH Terminal Block Type	Ezi-IO-EN-I32N-T	32CH Terminal Block Type
Ezi-IO-EN-I16P-T			
Ezi-IO-EN-O16N-T			
Ezi-IO-EN-O16P-T			
Ezi-IO-EN-I8O8N-T			
Ezi-IO-EN-I8O8P-T			

● Specifications of Module

Model		Ezi-IO-EN-I16□-■	Ezi-IO-EN-O16□-■	Ezi-IO-EN-I808□-■
Input Voltage		DC24V±10%		
Current Consumption		Max, 150mA (Except load current)		
Operating Condition	Ambient Temperature	<ul style="list-style-type: none"> · In Use: 0~50°C · In Storage: -20~70°C 		
	Humidity	<ul style="list-style-type: none"> · In Use: 35~85% RH (Non-Condensing) · In Storage: 10~90% RH (Non-Condensing) 		
	Vib. Resist.	0.5g		
Function	Input	Number of Input Channels	16CH	8CH
		Rated Input Voltage	DC24V	DC24V
		Rated Input Current	5mA/CH	5mA/CH
		Isolation Method	None	None
		Common Method	16CH/COM	8CH/COM
		Off→On Response Time	10μs or lower	10μs or lower
		On→Off Response Time	70μs or lower	70μs or lower
	Output	Number of Output Channels	16CH	8CH
		Rated Output Voltage	DC24V	DC24V
		Rated Output Current	0.2A/CH	0.2A/CH
		Isolation Method	None	None
		Common Method	16CH/COM	8CH/COM
		Off→On Response Time	4μs or lower	4μs or lower
		On→Off Response Time	140μs or lower	140μs or lower
LED Display		<ul style="list-style-type: none"> · Power Status (PWR) · Run Status (RUN) · Ethernet Status (Link, Activity) · I/O Status (0~15) 		<ul style="list-style-type: none"> · Power Status (PWR) · Run Status (RUN) · Ethernet Status (Link, Activity) · I/O Status (0~7/0~7)
Communication Interface		<ul style="list-style-type: none"> · Ethernet UDP/TCP Communication · Ethernet standard: 10BASE-T, 100BASE-TX · Full-Duplex 		
GUI		User Interface Program within Windows		
Library		Motion Library (API) for windows 7/8/10		

* □: NPN / PNP Type
 ■: e-CON / Terminal Block Type

● Specifications of Module

Model		Ezi-IO-EN-I32□-■	Ezi-IO-EN-O32□-■	Ezi-IO-EN-I16O16□-■	
Input Voltage		DC24V±10%			
Current Consumption		· Control Power : Max, 140mA · I/O Power : Max, 110mA (Except Load Current)	· Control Power : Max, 200mA · I/O Power : Max, 70mA (Except Load Current)	· Control Power : Max, 170mA · I/O Power : Max, 90mA (Except Load Current)	
Operating Condition	Ambient Temperature	· In Use: 0~50°C · In Storage: -20~70°C			
	Humidity	· In Use: 35~85% RH (Non-Condensing) · In Storage: 10~90% RH (Non-Condensing)			
	Vib, Resist,	0,5g			
Function	Input	Number of Input Channels	32CH	16CH	
		Rated Input Voltage	DC24V	DC24V	
		Rated Input Current	5mA/CH	5mA/CH	
		Isolation Method	Photocoupler Isolation	Photocoupler Isolation	
		Common Method	16CH/COM	16CH/COM	
		Off→On Response Time	10μs or lower	10μs or lower	
		On→Off Response Time	70μs or lower	70μs or lower	
	Output	Number of Output Channels	-	32CH	16CH
		Rated Output Voltage	-	DC24V	DC24V
		Rated Output Current	-	0,2A/CH	0,2A/CH
		Isolation Method	-	Photocoupler Isolation	Photocoupler Isolation
		Common Method	-	16CH/COM	16CH/COM
		Off→On Response Time	-	4μs or lower	4μs or lower
		On→Off Response Time	-	140μs or lower	140μs or lower
		LED Display	· Power Status (PWR) · Run Status (RUN) · Ethernet Status (Link, Activity) · I/O Status (0~31)		· Power Status (PWR) · Run Status (RUN) · Ethernet Status (Link, Activity) · I/O Status (0~15/0~15)
Communication Interface	· Ethernet UDP/TCP Communication · Ethernet standard: 10BASE-T, 100BASE-TX · Full-Duplex				
GUI	User Interface Program within Windows				
Library	Motion Library (API) for windows 7/8/10				

* □: NPN / PNP Type

■: e-CON / Terminal Block Type

● Dimensions of Module [mm]

◆ 16CH e-CON Type

- Model : Ezi-IO-EN-I16□-E, Ezi-IO-EN-O16□-E, Ezi-IO-EN-I808□-E

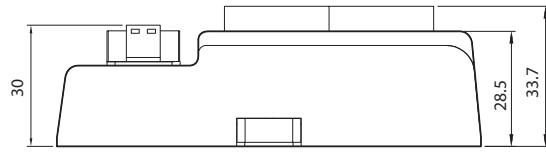
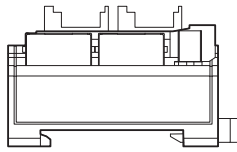
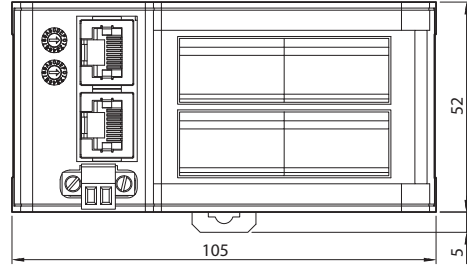
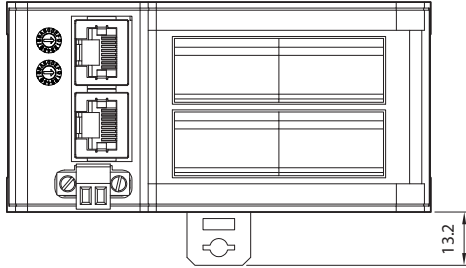

◆ 16CH Terminal Block Type

- Model : Ezi-IO-EN-I16□-T, Ezi-IO-EN-O16□-T, Ezi-IO-EN-I808□-T

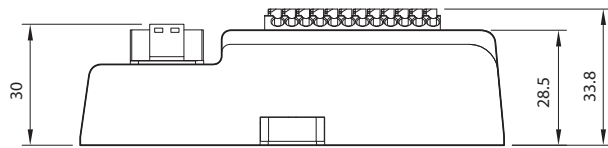
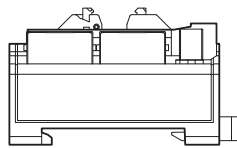
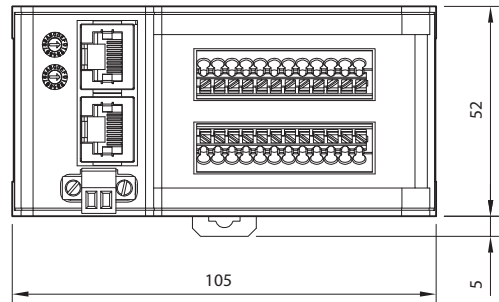
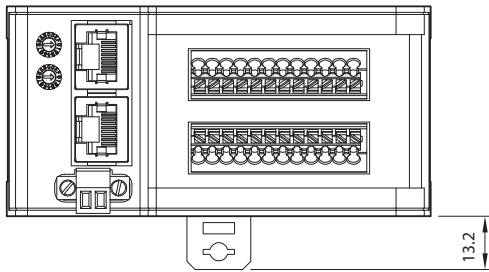

* □ : NPN / PNP Type

* Install the product on a din rail with a width of 35 mm.

● Dimensions of Module [mm]

◆ 32CH e-CON Type

- Model : Ezi-IO-EN-I32□-E, Ezi-IO-EN-O32□-E, Ezi-IO-EN-I16O16□-E

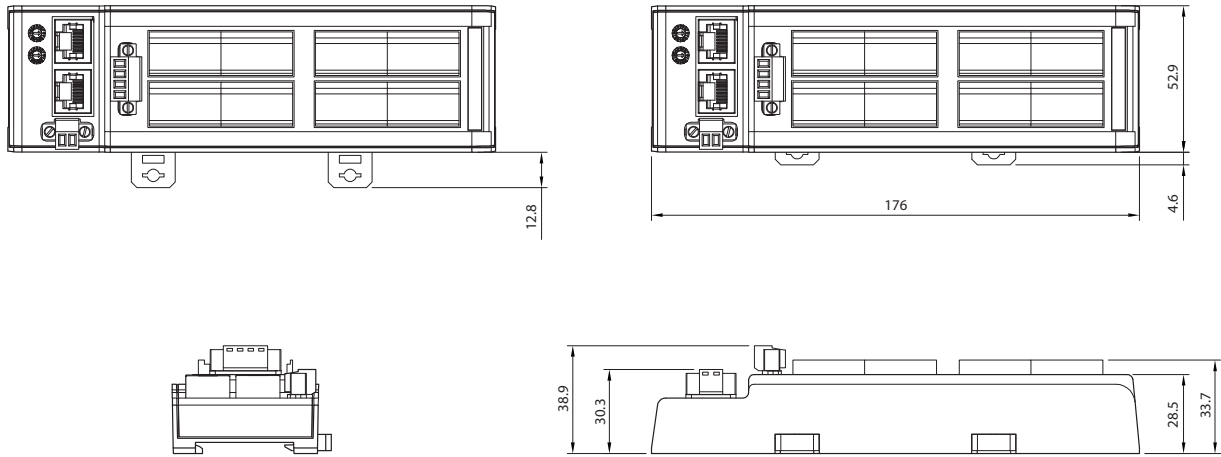

◆ 32CH Terminal Block Type

- Model : Ezi-IO-EN-I32□-T, Ezi-IO-EN-O32□-T, Ezi-IO-EN-I16O16□-T

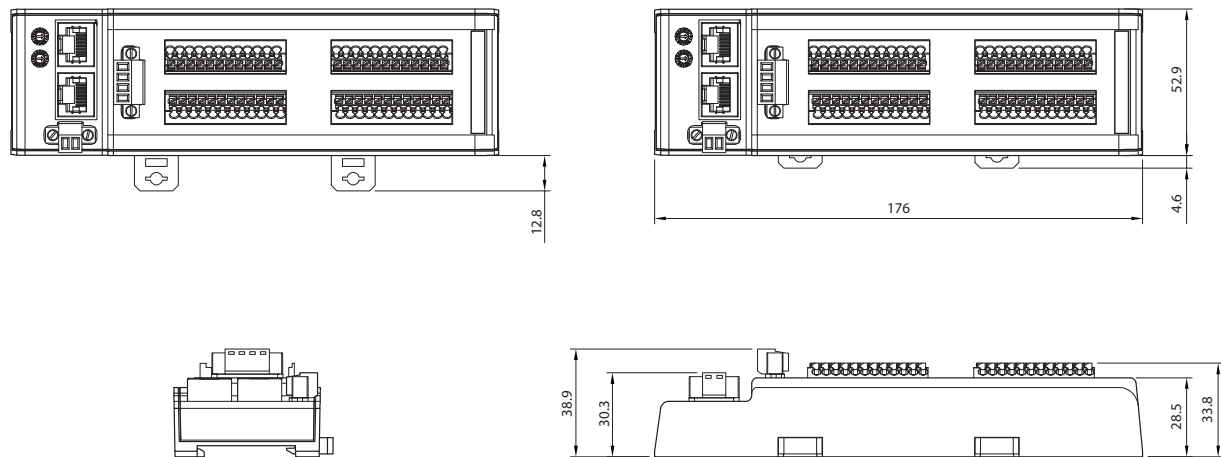

* □ : NPN / PNP Type

* Install the product on a din rail with a width of 35 mm,

● Settings and Operation [16CH e-CON Type]

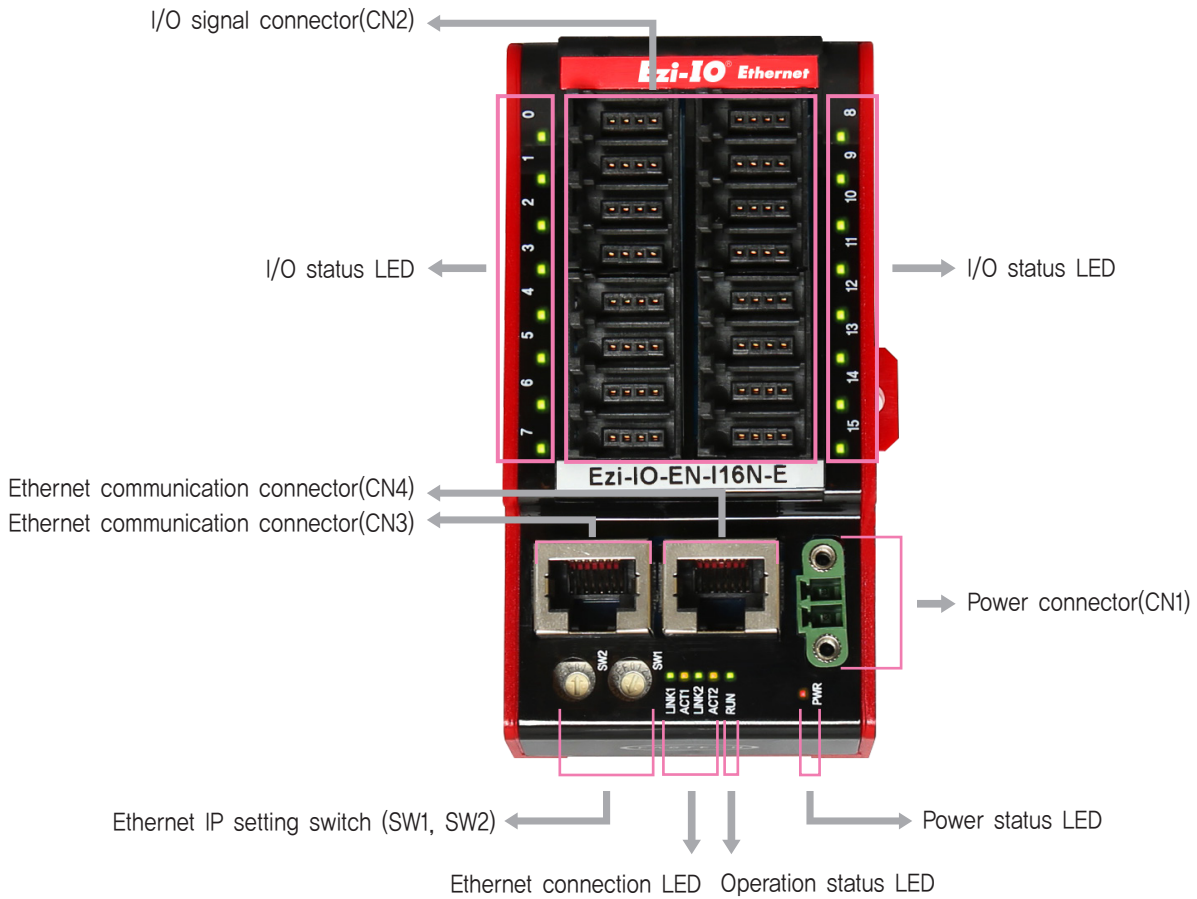

1. Status LED

● Power Status LED

Name	Color	Status	Description
PWR	Red	OFF	Power is OFF
		ON	Power is ON

● Operation Status LED

Name	Color	Status	Description
RUN	Green	OFF	Abnormal Operation
		Blinking	Normal Operation

● Ethernet Connection LED

Name	Color	Status	Description
LINK1/LINK2	Green	OFF	Link not Established
		ON	Link Established

● Ethernet Connection LED

Name	Color	Status	Description
ACT1/ACT2	Yellow	OFF	Stand-by
		Flickering	In Operation

● I/O status LED

Name*	Color	Status	Description
0~15 0~7 / 0~7	Green	OFF	Input Module : Input is OFF Output Module : Output is OFF
		ON	Input Module : Input is ON Output Module : Output is ON

* For Ezi-IO-EN-I808N-E and Ezi-IO-EN-I808P-E modules, the name is written as 0~7 / 0~7 .

2. Ethernet IP Setting Switch (SW1, SW2)

These switches set the 4th octet of Ethernet IP. The 1st octet, the 2nd octet, and the 3rd octet are set by GUI. If the switches are set to 255(FF), DHCP function is activated, and IP is automatically set, ignoring the set value. (Please refer to the manual for details.)

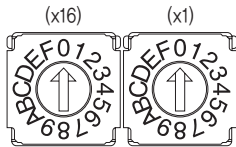

e.g.,) In case of SW2 : 5 and SW1 : 7
 $(5 \times 16) + (7 \times 1) = 87$
 IP is to be set as 192.168.0.87

3. Power Connector (CN1)

No.	Function	I/O
1	DC24V	Input
2	GND	Input

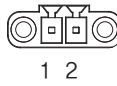

4. I/O Signal Connector (CN2)

No.	Function	I/O
1	DC24V	Output
2	NC	----
3	GND	Output
4	SIGNAL	I/O

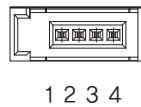

5. Ethernet Communication Connector (CN3, CN4)

No.	Function
1	TD+
2	TD-
3	RD+
4	----
5	----
6	RD-
7	----
8	----
Connector hood	F.GND

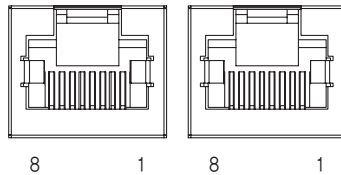

● Settings and Operation [16CH Terminal Block Type]

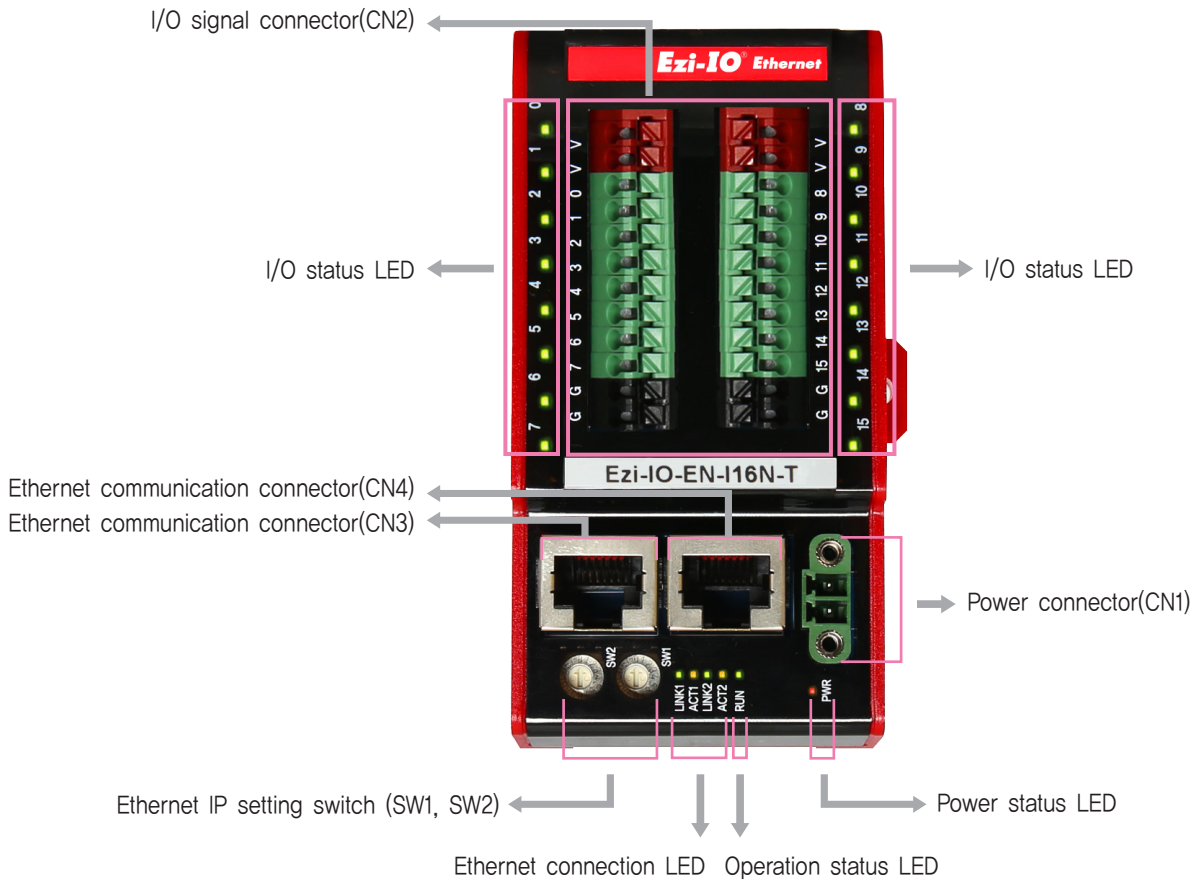

1. Status LED

● Power Status LED

Name	Color	Status	Description
PWR	Red	OFF	Power is OFF
		ON	Power is ON

● Operation Status LED

Name	Color	Status	Description
RUN	Green	OFF	Abnormal Operation
		Blinking	Normal Operation

● Ethernet Connection LED

Name	Color	Status	Description
LINK1/LINK2	Green	OFF	Link not Established
		ON	Link Established

● Ethernet Connection LED

Name	Color	Status	Description
ACT1/ACT2	Yellow	OFF	Stand-by
		Flickering	In Operation

● I/O status LED

Name*	Color	Status	Description
0~15 0~7 / 0~7	Green	OFF	Input Module : Input is OFF Output Module : Output is OFF
		ON	Input Module : Input is ON Output Module : Output is ON

* For Ezi-IO-EN-I808N-T and Ezi-IO-EN-I808P-T modules, the name is written as 0~7 / 0~7 .

2. Ethernet IP Setting Switch (SW1, SW2)

These switches set the 4th octet of Ethernet IP. The 1st octet, the 2nd octet, and the 3rd octet are set by GUI. If the switches are set to 255(FF), DHCP function is activated, and IP is automatically set, ignoring the set value. (Please refer to the manual for details.)

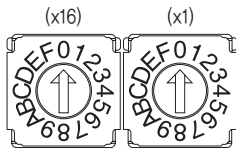

e.g.,) In case of SW2 : 5 and SW1 : 7
 $(5 \times 16) + (7 \times 1) = 87$
 IP is to be set as 192.168.0.87

3. Power Connector (CN1)

No.	Function	I/O
1	DC24V	Input
2	GND	Input

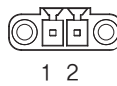

4. I/O Signal Connector (CN2)

No.	Name*	Function	I/O
1	V	DC24V	Output
2	V	DC24V	Output
3	0	SIGNAL	I/O
4	1	SIGNAL	I/O
5	2	SIGNAL	I/O
6	3	SIGNAL	I/O
7	4	SIGNAL	I/O
8	5	SIGNAL	I/O
9	6	SIGNAL	I/O
10	7	SIGNAL	I/O
11	G	GND	Output
12	G	GND	Output
13	V	DC24V	Output
14	V	DC24V	Output
15	8(0)	SIGNAL	I/O
16	9(1)	SIGNAL	I/O
17	10(2)	SIGNAL	I/O
18	11(3)	SIGNAL	I/O
19	12(4)	SIGNAL	I/O
20	13(5)	SIGNAL	I/O
21	14(6)	SIGNAL	I/O
22	15(7)	SIGNAL	I/O
23	G	GND	Output
24	G	GND	Output

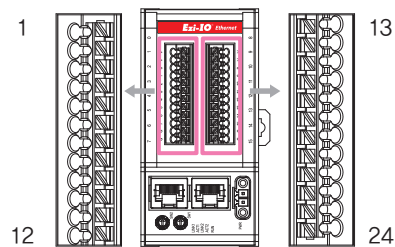

* For Ezi-IO-EN-I808N-T and Ezi-IO-EN-I808P-T modules, the name is written as 0~7 / 0~7 .

5. Ethernet Communication Connector (CN3, CN4)

No.	Function
1	TD+
2	TD-
3	RD+
4	----
5	----
6	RD-
7	----
8	----
Connector hood	F_GND

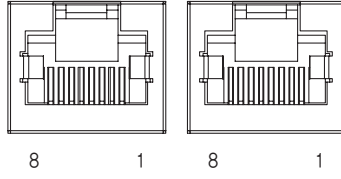

● Settings and Operation [32CH e-CON Type]

FASTECH Ezi-IO Ethernet DIO

I/O signal connector(CN2)

I/O status LED

I/O status LED

I/O power connector(CN5)

Ethernet communication connector(CN4)

Ethernet communication connector(CN3)

Control power connector(CN1)

Ethernet IP setting switch (SW1, SW2)

Power status LED

Ethernet connection LED Operation status LED

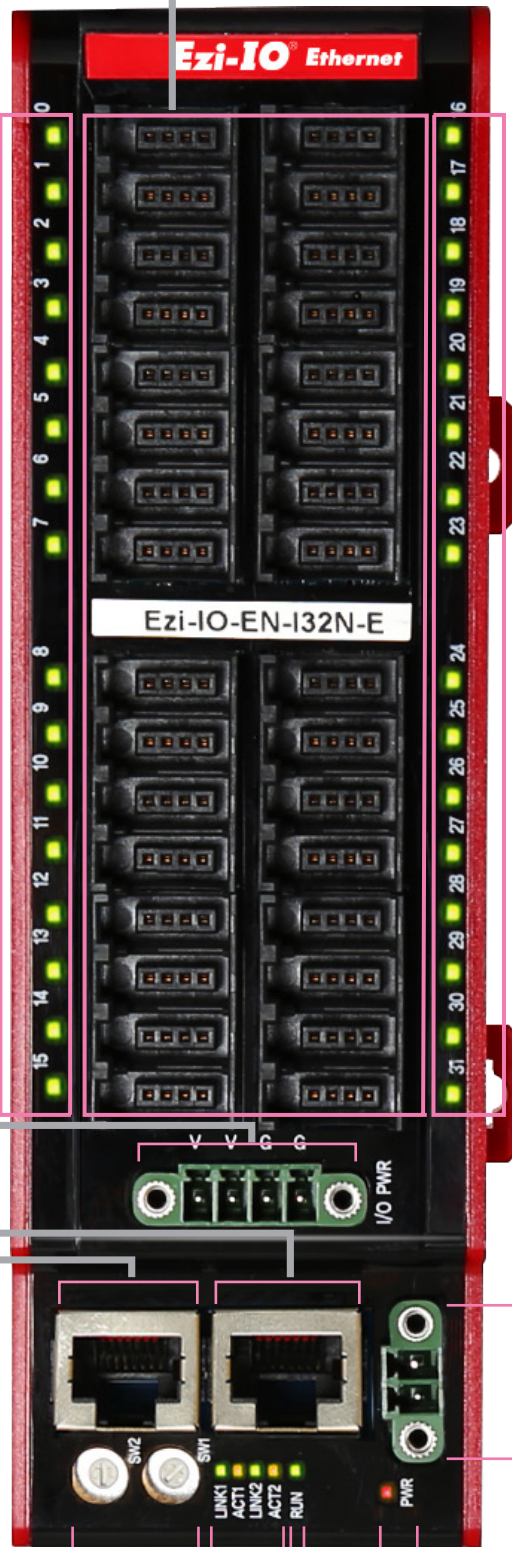

1. Status LED

• Power Status LED

Name	Color	Status	Description
PWR	Red	OFF	Power is OFF
		ON	Power is ON

• Operation Status LED

Name	Color	Status	Description
RUN	Green	OFF	Abnormal Operation
		Blinking	Normal Operation

• Ethernet Connection LED

Name	Color	Status	Description
LINK1/LINK2	Green	OFF	Link not Established
		ON	Link Established

• Ethernet Connection LED

Name	Color	Status	Description
ACT1/ACT2	Yellow	OFF	Stand-by
		Flickering	In Operation

• I/O status LED

Name*	Color	Status	Description
0~31 0~15 / 0~15	Green	OFF	Input Module : Input is OFF Output Module : Output is OFF
		ON	Input Module : Input is ON Output Module : Output is ON

* For Ezi-I/O-PE-I16016N-E and Ezi-I/O-PE-I16016P-E modules, the name is written as 0~15 / 0~15 .

2. Ethernet IP Setting Switch (SW1, SW2)

These switches set the 4th octet of Ethernet IP. The 1st octet, the 2nd octet, and the 3rd octet are set by GUI. If the switches are set to 255(FF), DHCP function is activated, and IP is automatically set, ignoring the set value. (Please refer to the manual for details.)

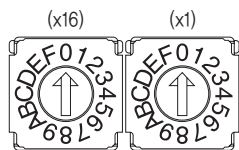

e.g.,) In case of SW2 : 5 and SW1 : 7
 $(5 \times 16) + (7 \times 1) = 87$
 IP is to be set as 192.168.0.87

3. Power Connector (CN1)

No.	Function	I/O
1	DC24V	Input
2	GND	Input



1 2

4. I/O Signal Connector (CN2)

No.	Function	I/O
1	EXT_DC24V	Output
2	NC	-----
3	EXT_GND	Output
4	SIGNAL	I/O

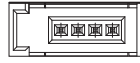

1 2 3 4

5. Ethernet Communication Connector (CN3, CN4)

No.	Function
1	TD+
2	TD-
3	RD+
4	-----
5	-----
6	RD-
7	-----
8	-----
Connector hood	F.GND

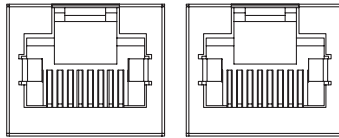

8 1 8 1

6. I/O Power Connector (CN5)

No.	Function	I/O
1	EXT_DC24V	Input
2	EXT_DC24V	Input
3	EXT_GND	Input
4	EXT_GND	Input



1 2 3 4

● Settings and Operation [32CH Terminal Block Type]

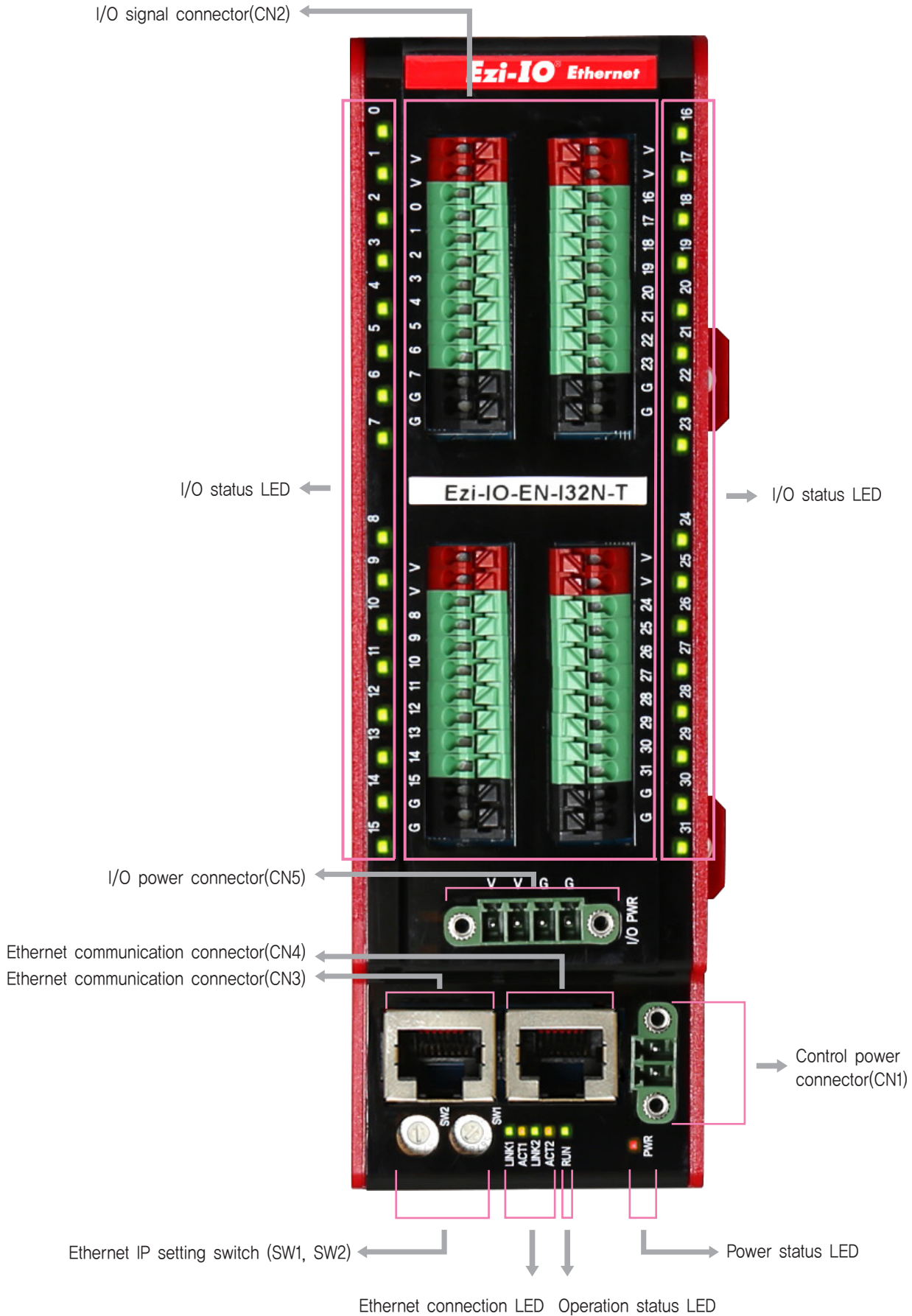

1. Status LED

● Power Status LED

Name	Color	Status	Description
PWR	Red	OFF	Power is OFF
		ON	Power is ON

● Operation Status LED

Name	Color	Status	Description
RUN	Green	OFF	Abnormal Operation
		Blinking	Normal Operation

● Ethernet Connection LED

Name	Color	Status	Description
LINK1/LINK2	Green	OFF	Link not Established
		ON	Link Established

● Ethernet Connection LED

Name	Color	Status	Description
ACT1/ACT2	Yellow	OFF	Stand-by
		Flickering	In Operation

● I/O status LED

Name*	Color	Status	Description
0~31 0~15 / 0~15	Green	OFF	Input Module : Input is OFF Output Module : Output is OFF
		ON	Input Module : Input is ON Output Module : Output is ON

* For Ezi-IO-PE-I16016N-T and Ezi-IO-PE-I16016P-T modules, the name is written as 0~15 / 0~15 .

2. Ethernet IP Setting Switch (SW1, SW2)

These switches set the 4th octet of Ethernet IP. The 1st octet, the 2nd octet, and the 3rd octet are set by GUI. If the switches are set to 255(FF), DHCP function is activated, and IP is automatically set, ignoring the set value. (Please refer to the manual for details.)

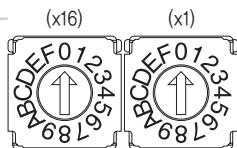

e.g.,) In case of SW2 : 5 and SW1 : 7
 $(5 \times 16) + (7 \times 1) = 87$
 IP is to be set as 192.168.0.87

3. Power Connector (CN1)

No.	Function	I/O
1	DC24V	Input
2	GND	Input

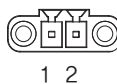

4. I/O Signal Connector (CN2)

No.	Name*	Function	I/O
1	V	EXT_DC24V	Output
2	V	EXT_DC24V	Output
3	0	SIGNAL	I/O
4	1	SIGNAL	I/O
5	2	SIGNAL	I/O
6	3	SIGNAL	I/O
7	4	SIGNAL	I/O
8	5	SIGNAL	I/O
9	6	SIGNAL	I/O
10	7	SIGNAL	I/O
11	G	EXT_GND	Output
12	G	EXT_GND	Output
13	V	EXT_DC24V	Output
14	V	EXT_DC24V	Output
15	8	SIGNAL	I/O
16	9	SIGNAL	I/O
17	10	SIGNAL	I/O
18	11	SIGNAL	I/O
19	12	SIGNAL	I/O
20	13	SIGNAL	I/O
21	14	SIGNAL	I/O
22	15	SIGNAL	I/O
23	G	EXT_GND	Output
24	G	EXT_GND	Output

No.	Name*	Function	I/O
25	V	EXT_DC24V	Output
26	V	EXT_DC24V	Output
27	16(0)	SIGNAL	I/O
28	17(1)	SIGNAL	I/O
29	18(2)	SIGNAL	I/O
30	19(3)	SIGNAL	I/O
31	20(4)	SIGNAL	I/O
32	21(5)	SIGNAL	I/O
33	22(6)	SIGNAL	I/O
34	23(7)	SIGNAL	I/O
35	G	EXT_GND	Output
36	G	EXT_GND	Output
37	V	EXT_DC24V	Output
38	V	EXT_DC24V	Output
39	24(8)	SIGNAL	I/O
40	25(9)	SIGNAL	I/O
41	26(10)	SIGNAL	I/O
42	27(11)	SIGNAL	I/O
43	28(12)	SIGNAL	I/O
44	29(13)	SIGNAL	I/O
45	30(14)	SIGNAL	I/O
46	31(15)	SIGNAL	I/O
47	G	EXT_GND	Output
48	G	EXT_GND	Output

* For Ezi-IO-PE-I16016N-T and Ezi-IO-PE-I16016P-T modules, the name is written as 0~15 / 0~15 .

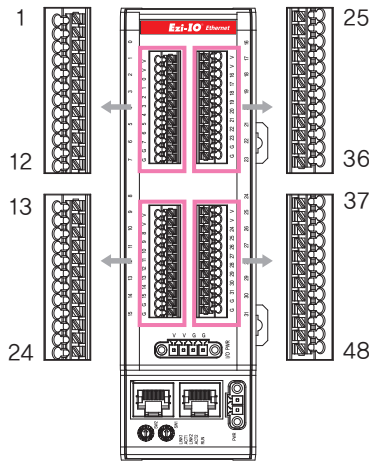

5. Ethernet Communication Connector (CN3, CN4)

No.	Function
1	TD+
2	TD-
3	RD+
4	----
5	----
6	RD-
7	----
8	----
Connector hood	F_GND

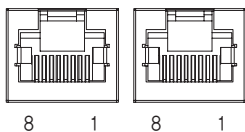

6. I/O Power Connector (CN5)

No.	Function	I/O
1	EXT_DC24V	Input
2	EXT_DC24V	Input
3	EXT_GND	Input
4	EXT_GND	Input



1 2 3 4

● System Configuration [16CH e-CON Type]

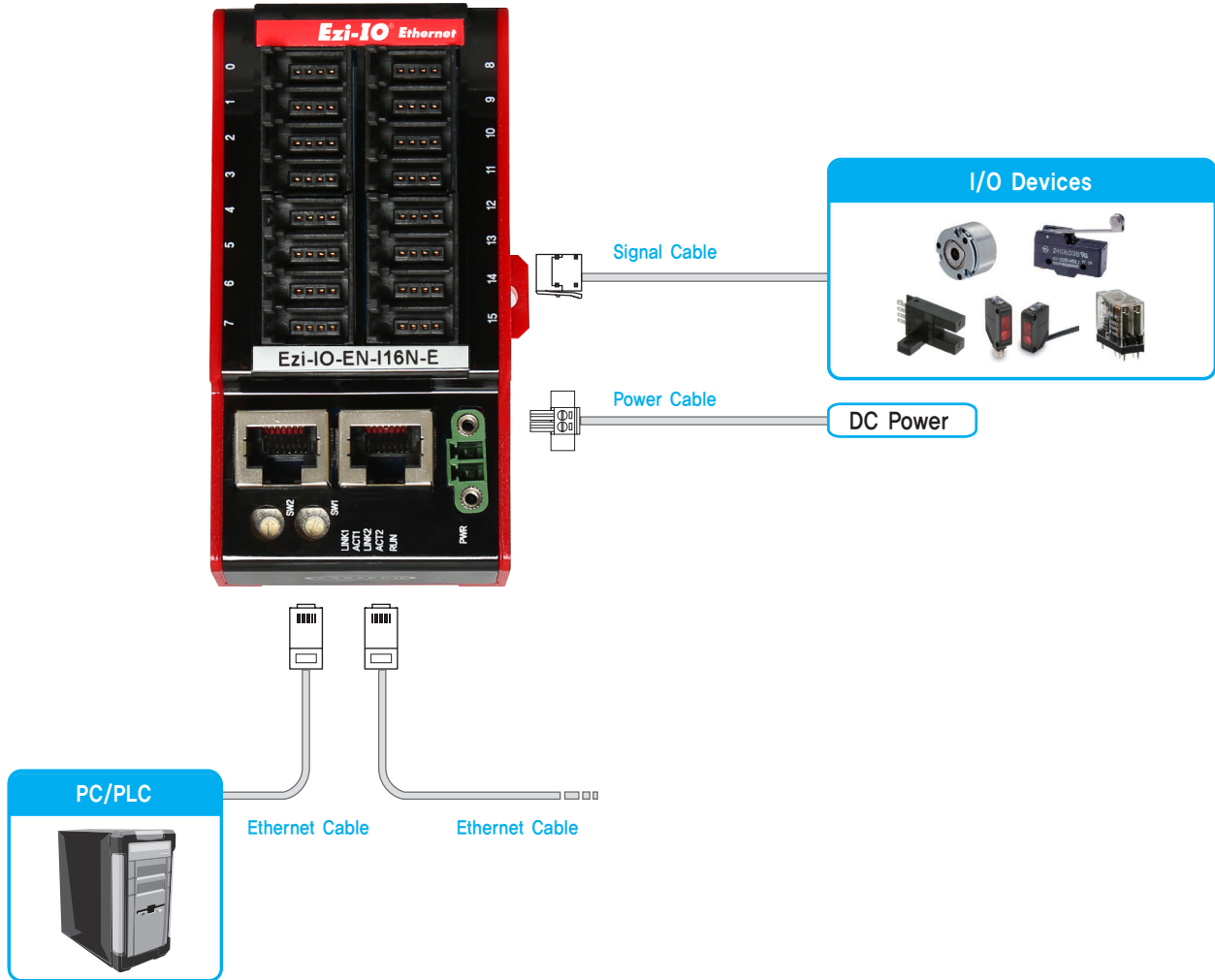

1. Accessories

● Connectors

Purpose	Item	Part Number	Manufacturer
Power (CN1)	Terminal Block	MC421-38102	DECA
Signal (CN2)	e-CON Plug Connector	CNE-P04-YW	Autonics

※ The connectors above are supplied with the product. If you are using other parts, please make sure they meet the specifications.

2. Options

● Ethernet Cable

Purpose	Part Number	Length [m]	Remarks
Ethernet Connection (CN3, CN4)	CGNR-EC-001F	1	· STP(Shielded Twisted Pair) Cable · Category 5e or higher · Maximum Length: 100m · Normal Cable
	CGNR-EC-002F	2	
	CGNR-EC-003F	3	
	CGNR-EC-005F	5	

* If you need cables with length(in units of 1m) not listed on the table or robot cables, please contact FASTECH for more information.

● System Configuration [16CH Terminal Block Type]

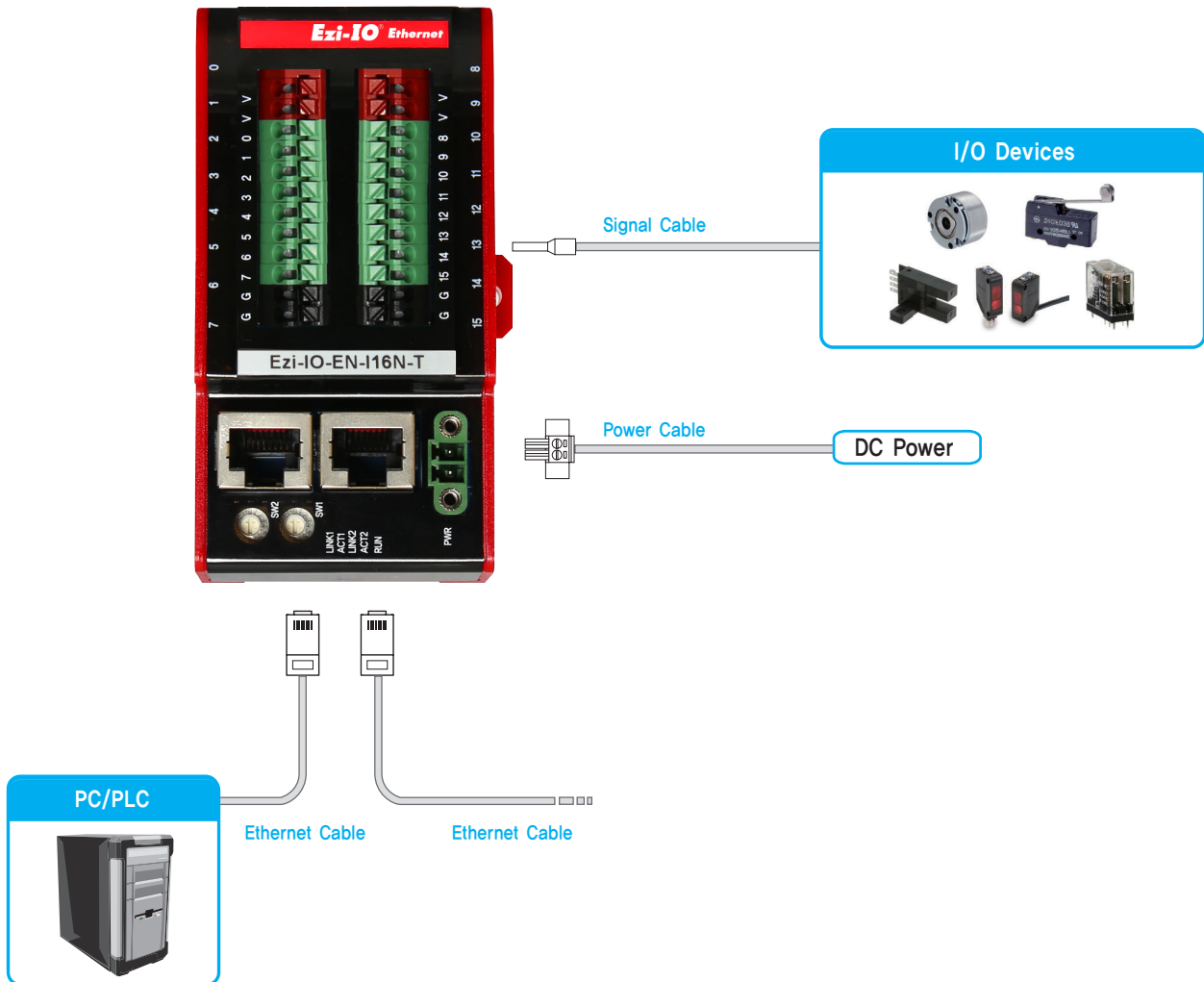

1. Accessories

● Connectors

Purpose	Item	Part Number	Manufacturer
Power (CN1)	Terminal Block	MC421-38102	DECA

※ The connectors above are supplied with the product. If you are using other parts, please make sure they meet the specifications.

2. Options

● Ethernet Cable

Purpose	Part Number	Length [m]	Remarks
Ethernet Connection (CN3, CN4)	CGNR-EC-001F	1	· STP(Shielded Twisted Pair) Cable · Category 5e or higher · Maximum Length: 100m · Normal Cable
	CGNR-EC-002F	2	
	CGNR-EC-003F	3	
	CGNR-EC-005F	5	

* If you need cables with length(in units of 1m) not listed on the table or robot cables, please contact FASTECH for more information.

● System Configuration [32CH e-CON Type]

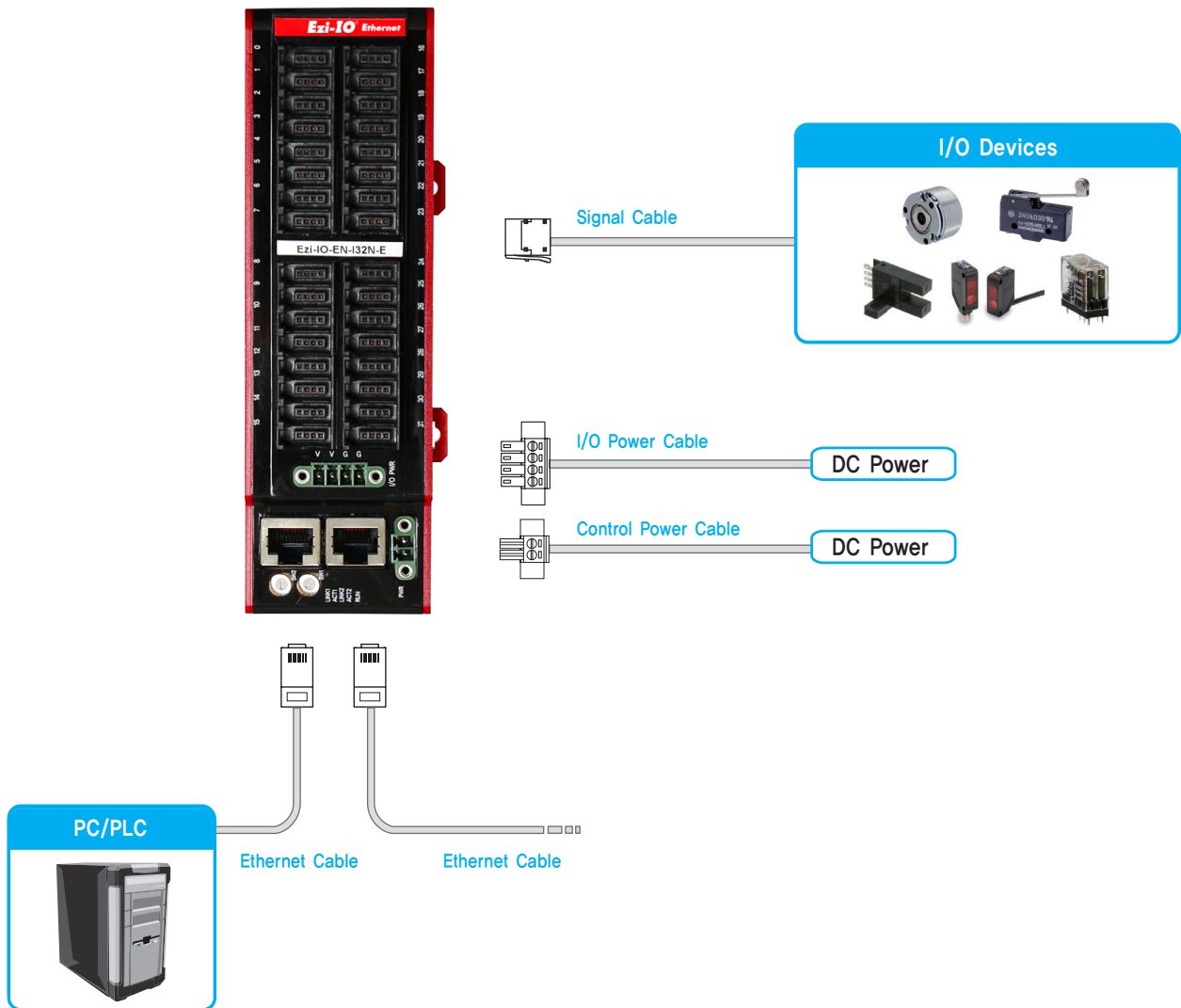

1. Accessories

● Connectors

Purpose	Item	Part Number	Manufacturer
Control Power(CN1)	Terminal Block	MC421-38102	DECA
I/O Power (CN5)	Terminal Block	MC421-38104	DECA
Signal (CN2)	e-CON Plug Connector	CNE-P04-YW	Autonics

※ The connectors above are supplied with the product. If you are using other parts, please make sure they meet the specifications.

2. Options

● Ethernet Cable

Purpose	Part Number	Length [m]	Remarks
Ethernet Connection (CN3, CN4)	CGNR-EC-001F	1	· STP(Shielded Twisted Pair) Cable · Category 5e or higher · Maximum Length: 100m · Normal Cable
	CGNR-EC-002F	2	
	CGNR-EC-003F	3	
	CGNR-EC-005F	5	

* If you need cables with length(in units of 1m) not listed on the table or robot cables, please contact FASTECH for more information.

● System Configuration [32CH Terminal Block Type]

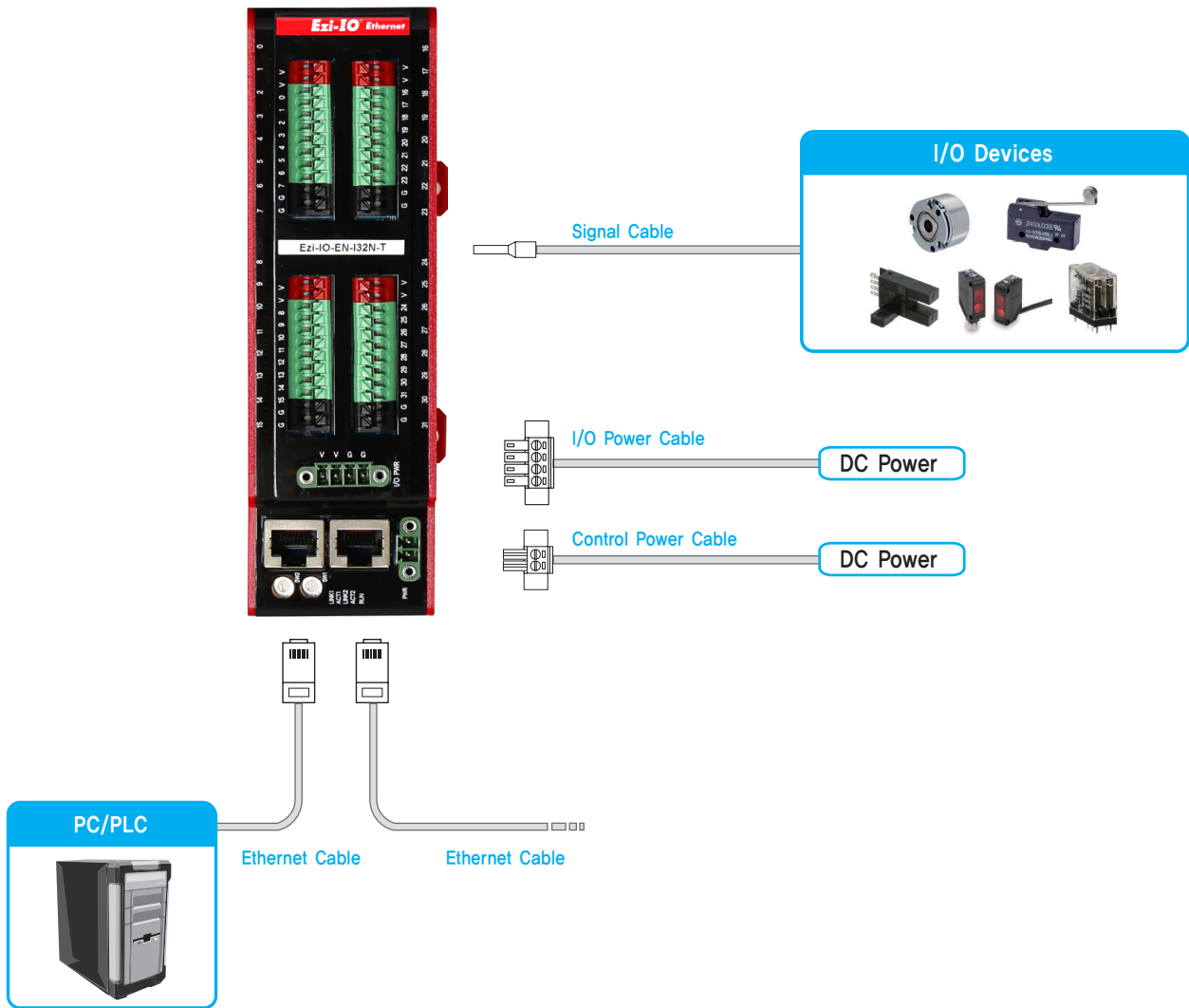

1. Accessories

● Connectors

Purpose	Item	Part Number	Manufacturer
Control Power(CN1)	Terminal Block	MC421-38102	DECA
I/O Power (CN5)	Terminal Block	MC421-38104	DECA

※ The connectors above are supplied with the product. If you are using other parts, please make sure they meet the specifications.

2. Options

● Ethernet Cable

Purpose	Part Number	Length [m]	Remarks
Ethernet Connection (CN3, CN4)	CGNR-EC-001F	1	· STP(Shielded Twisted Pair) Cable · Category 5e or higher · Maximum Length: 100m · Normal Cable
	CGNR-EC-002F	2	
	CGNR-EC-003F	3	
	CGNR-EC-005F	5	

* If you need cables with length(in units of 1m) not listed on the table or robot cables, please contact FASTECH for more information.

External Wiring Diagram [16CH e-CON Type]

1 Ezi-IO-EN-I16N-E(NPN)

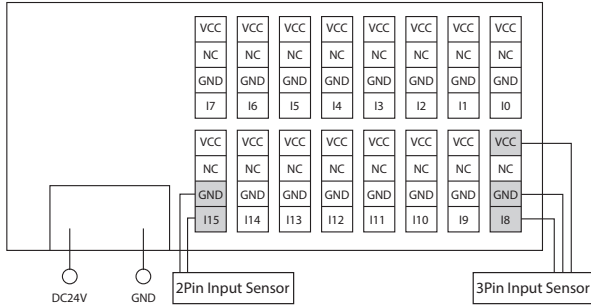

4 Ezi-IO-EN-O16P-E(PNP)

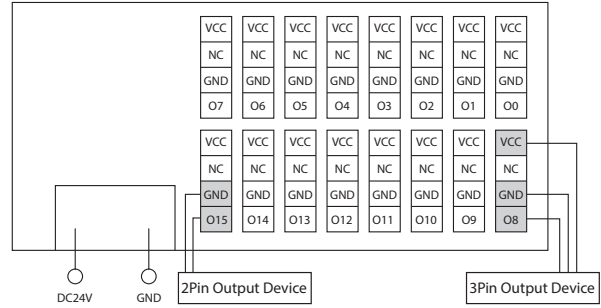

2 Ezi-IO-EN-I16P-E(PNP)

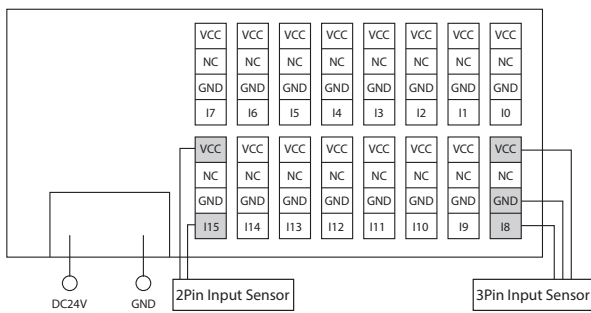

5 Ezi-IO-EN-I808N-E(NPN)

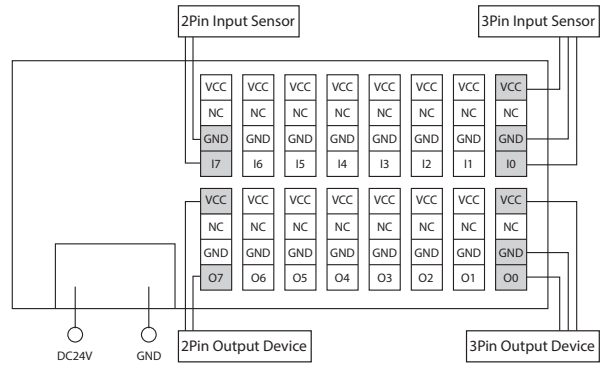

3 Ezi-IO-EN-O16N-E(NPN)

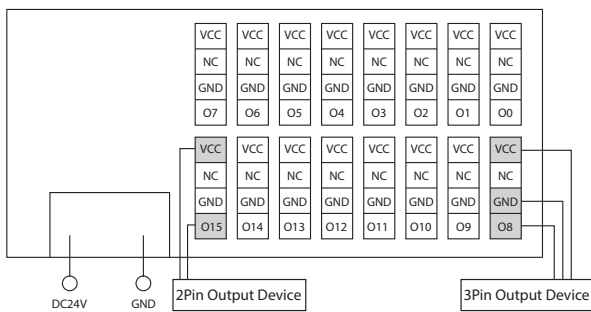

6 Ezi-IO-EN-I808P-E(PNP)

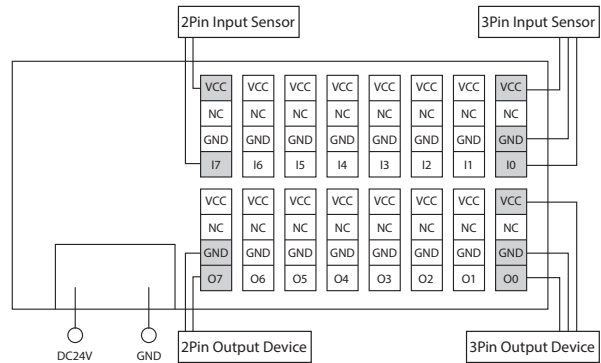

※ VCC is DC24V output.

※ e.g.) · 2Pin Input Sensor : Limit Sensor, etc.

· 3Pin Input Sensor : Position Sensor, Photo Sensor, Proximity Sensor, etc.

· 2Pin Output Device : Brake, Solenoid, Photocoupler, etc.

External Wiring Diagram [16CH Terminal Block Type]

1 Ezi-IO-EN-I16N-T(NPN)

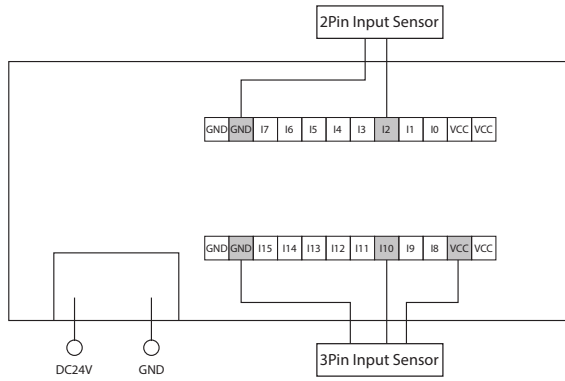

4 Ezi-IO-EN-O16P-T(PNP)

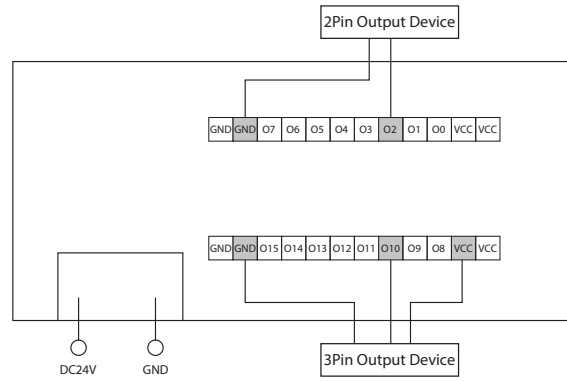

2 Ezi-IO-EN-I16P-T(PNP)

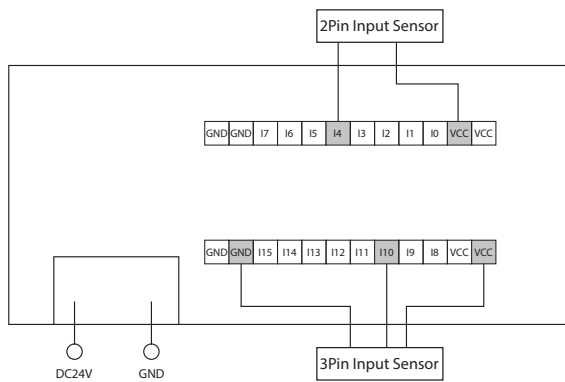

5 Ezi-IO-EN-I808N-T(NPN)

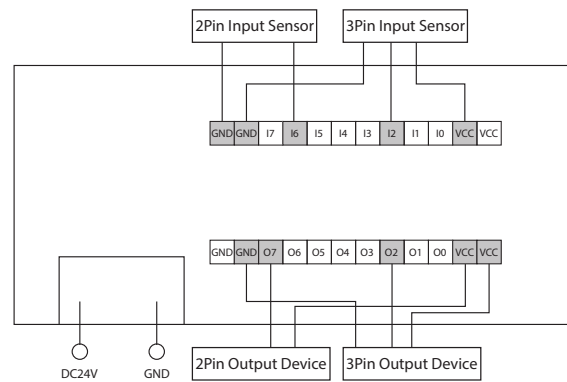

3 Ezi-IO-EN-O16N-T(NPN)

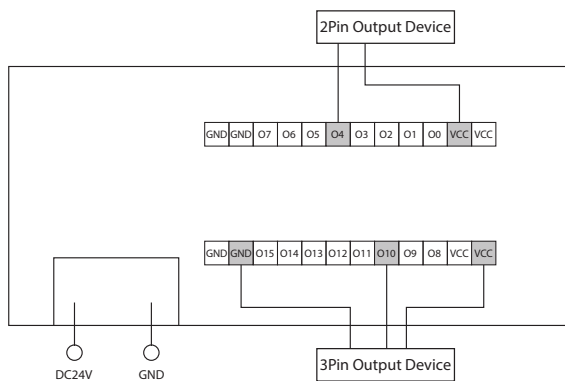

6 Ezi-IO-EN-I808P-T(PNP)

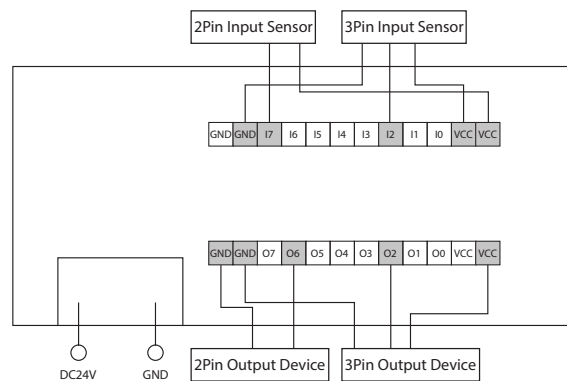

- ※ VCC is DC24V output.
- ※ e.g.)
 - 2Pin Input Sensor : Limit Sensor, etc.
 - 3Pin Input Sensor : Position Sensor, Photo Sensor, Proximity Sensor, etc.
 - 2Pin Output Device : Brake, Solenoid, Photocoupler, etc.

External Wiring Diagram [32CH e-CON Type]

1 Ezi-IO-EN-I32N-E(NPN)

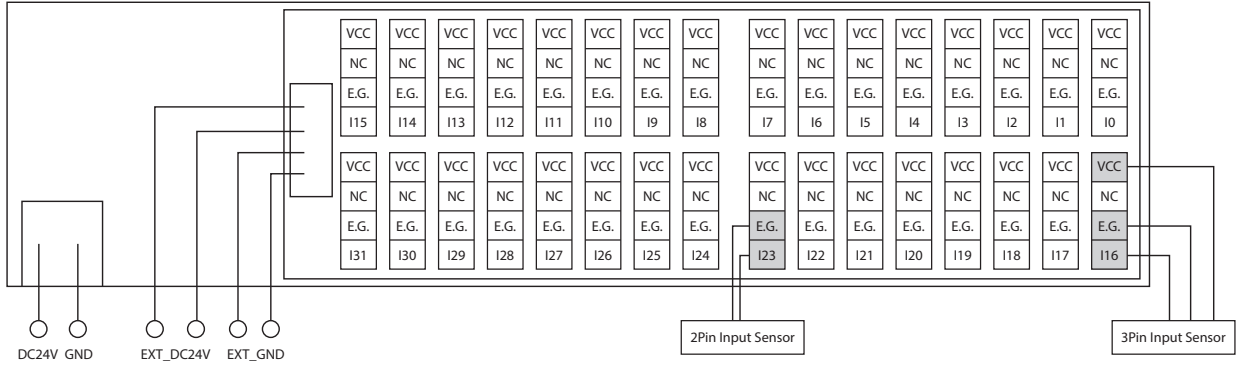

2 Ezi-IO-EN-I32P-E(PNP)

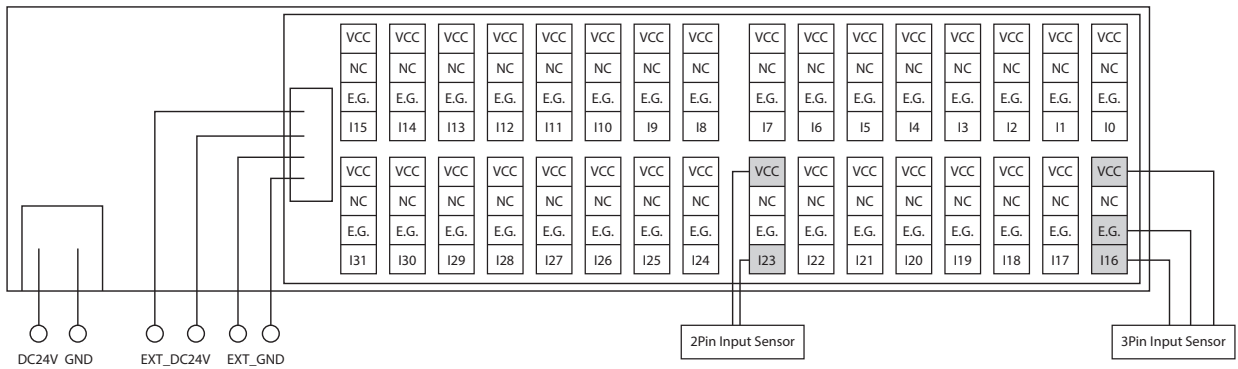

3 Ezi-IO-EN-O32N-E(NPN)

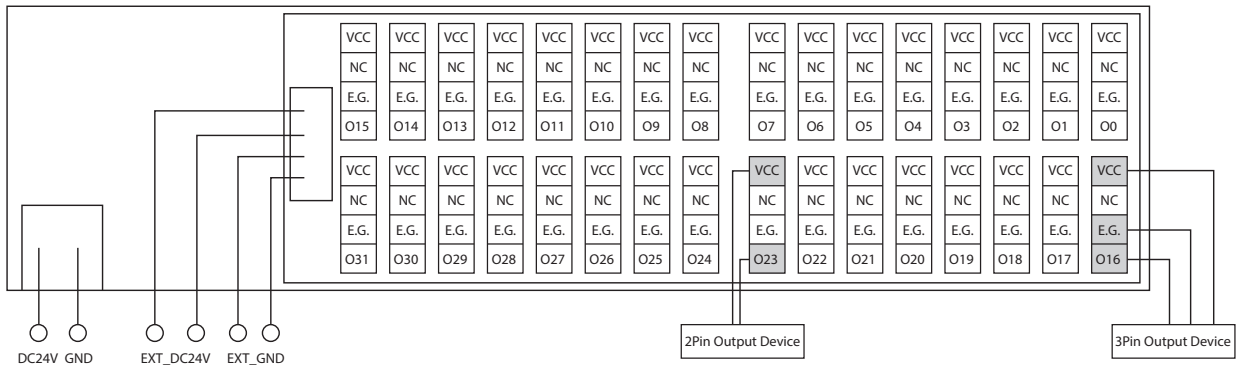

※ VCC and E,G are supplied from I/O Power Connector(CN5).

※ e.g.) · 2Pin Input Sensor : Limit Sensor, etc.

· 3Pin Input Sensor : Position Sensor, Photo Sensor, Proximity Sensor, etc.

· 2Pin Output Device : Brake, Solenoid, Photocoupler, etc.

External Wiring Diagram [32CH e-CON Type]

4 Ezi-IO-EN-032P-E(PNP)

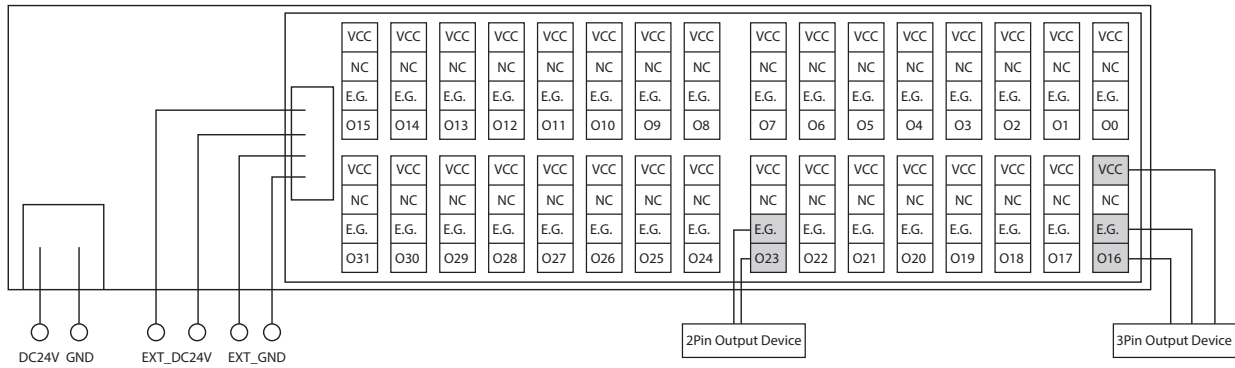

5 Ezi-IO-EN-I16016N-E(NPN)

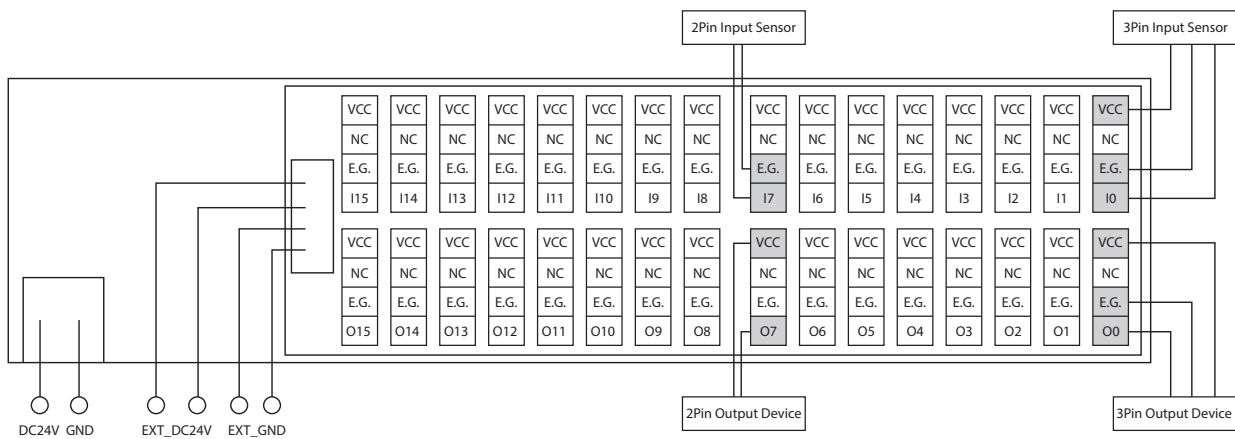

6 Ezi-IO-EN-I16016P-E(PNP)

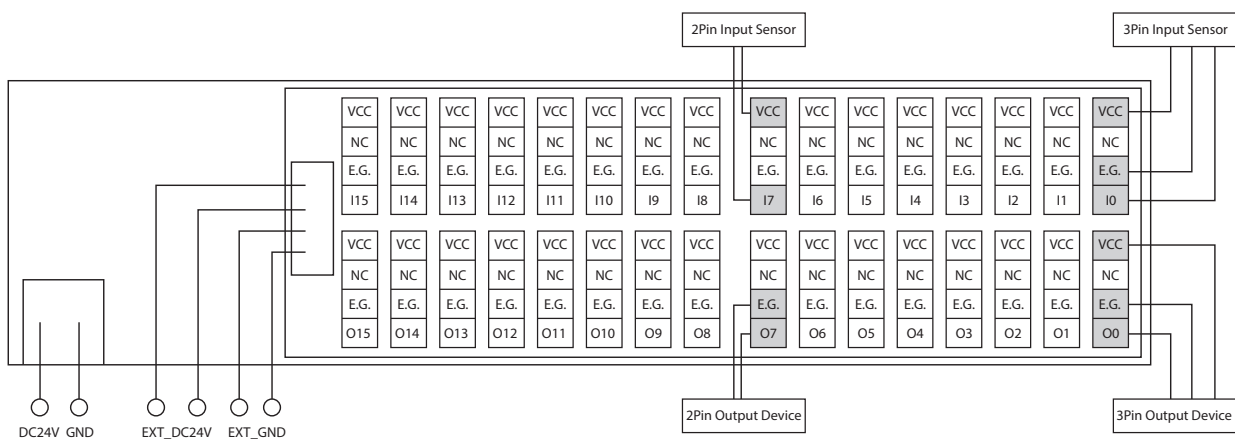

- ※ VCC and E.G are supplied from I/O Power Connector(CN5).
- ※ e.g.)
 - 2Pin Input Sensor : Limit Sensor, etc.
 - 3Pin Input Sensor : Position Sensor, Photo Sensor, Proximity Sensor, etc.
 - 2Pin Output Device : Brake, Solenoid, Photocoupler, etc.

External Wiring Diagram [32CH Terminal Block Type]

1 Ezi-IO-EN-I32N-T(NPN)

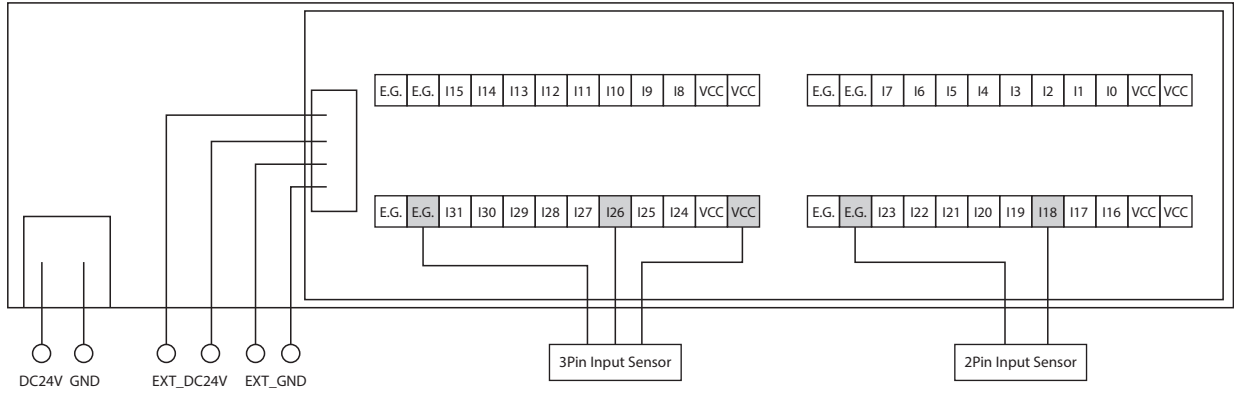

2 Ezi-IO-EN-I32P-T(PNP)

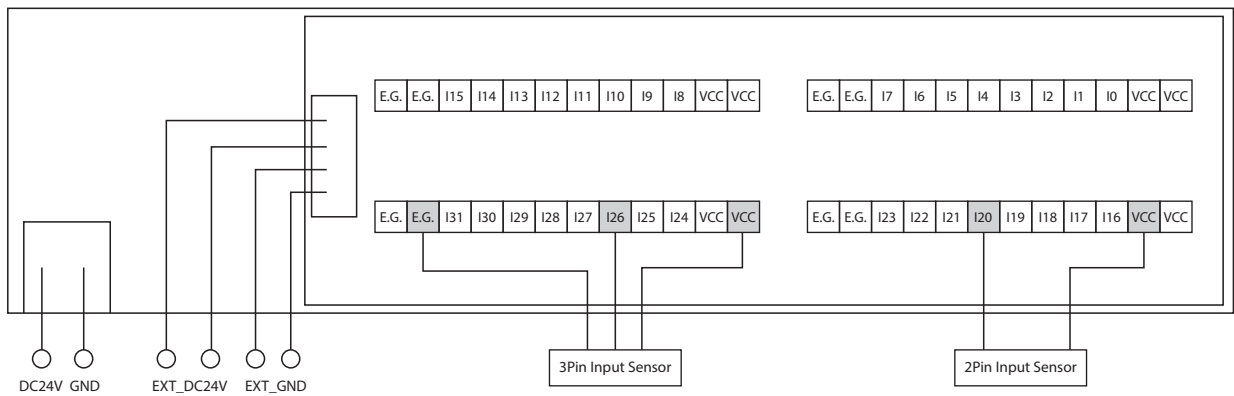

3 Ezi-IO-EN-O32N-T(NPN)

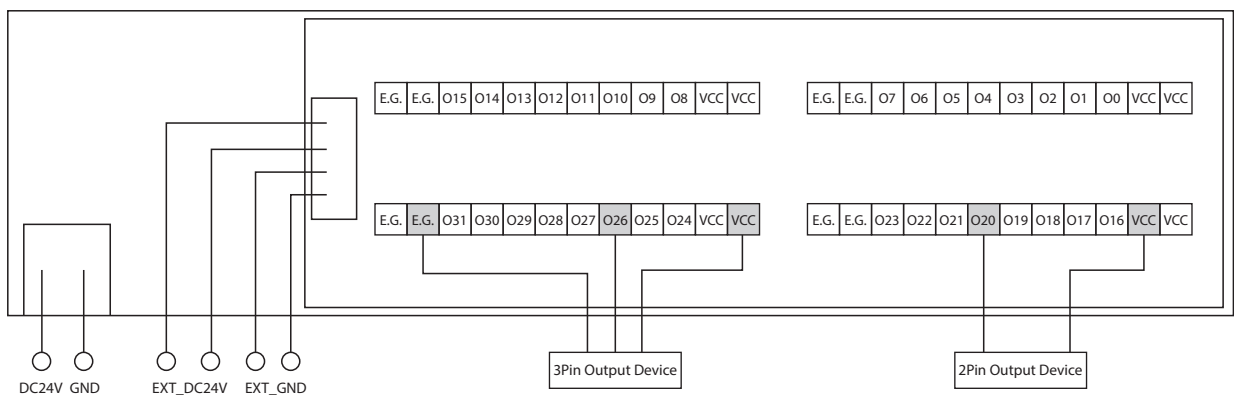

- ※ VCC and E,G are supplied from I/O Power Connector(CN5).
- ※ e.g.)
 - 2Pin Input Sensor : Limit Sensor, etc.
 - 3Pin Input Sensor : Position Sensor, Photo Sensor, Proximity Sensor, etc.
 - 2Pin Output Device : Brake, Solenoid, Photocoupler, etc.

External Wiring Diagram [32CH Terminal Block Type]

4 Ezi-IO-EN-032P-T(PNP)

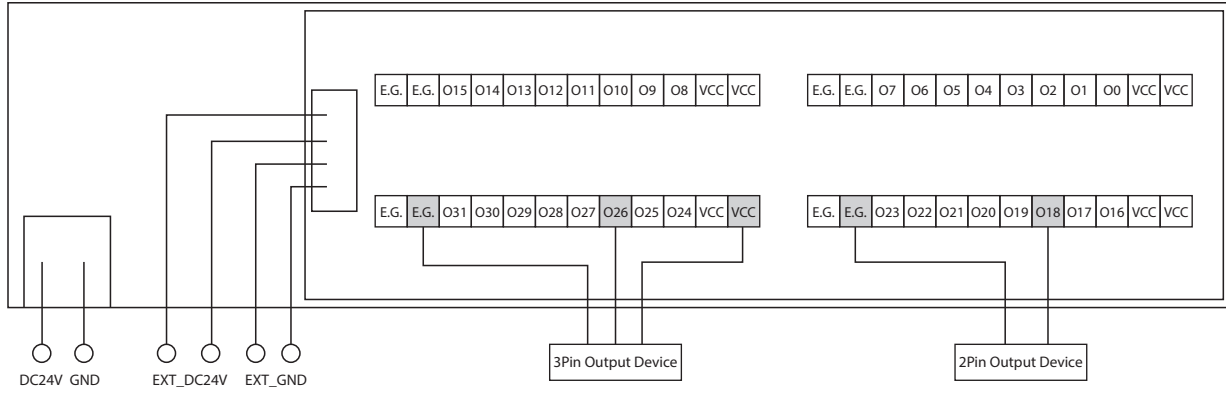

5 Ezi-IO-EN-I16O16N-T(NPN)

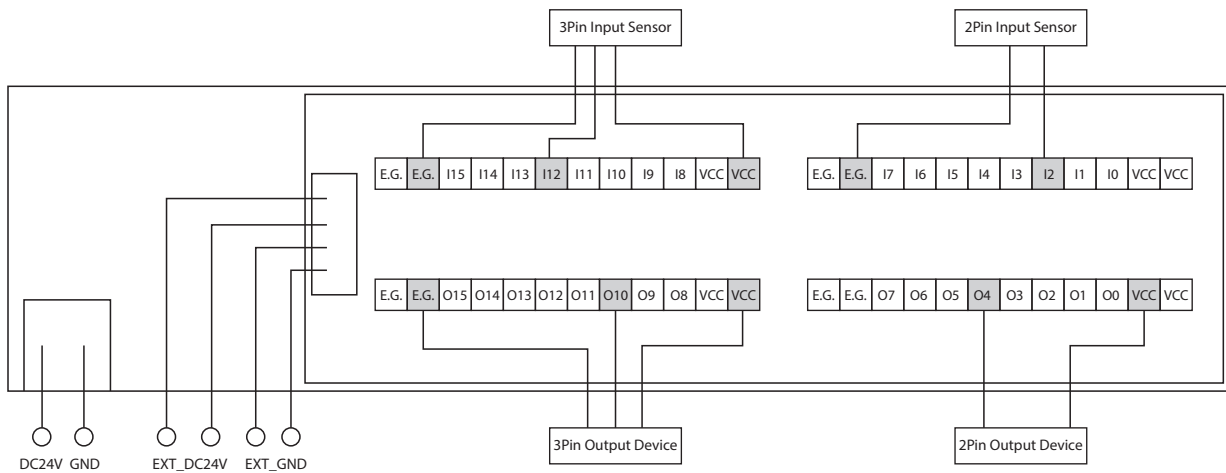

6 Ezi-IO-EN-I16O16P-T(PNP)

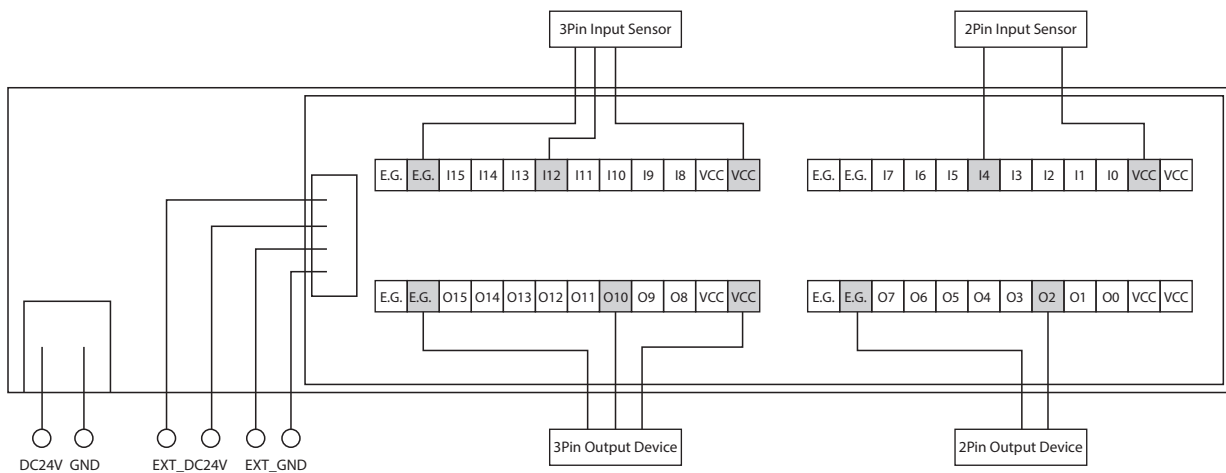

※ VCC and E.G are supplied from I/O Power Connector(CN5).

※ e.g.) · 2Pin Input Sensor : Limit Sensor, etc.

· 3Pin Input Sensor : Position Sensor, Photo Sensor, Proximity Sensor, etc.

· 2Pin Output Device : Brake, Solenoid, Photocoupler, etc.

● GUI(Graphic User Interface) Program

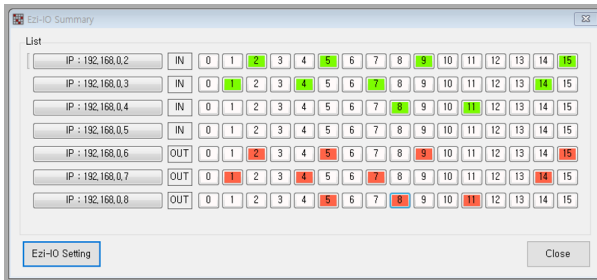

◆ Ezi-I/O Ethernet DIO Summary

The operation status of the connected I/O modules can be monitored at once.

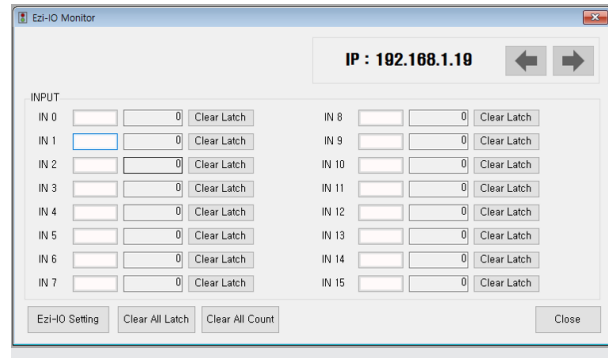

◆ Input Module Monitor

You can check the input status and latch status of each input channels.

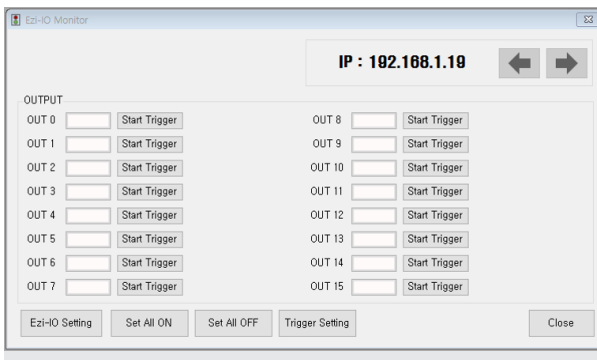

◆ Output Module Monitor

You can check the output status and trigger status of each output channels.

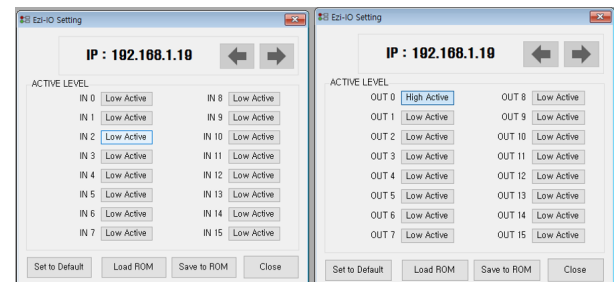

◆ I/O Logic Setting

This function selects the level of the actual signal to recognize the I/O signal as [ON]. All changes can be saved and restored when needed.

※ GUI Program(Ezi-MOTIONLINK Plus-E) can be downloaded from website, (www.fastech-motions.com)

※ GUI Program(Ezi-MOTIONLINK Plus-E) supports Windows 7/8/10.

※ GUI Program(Ezi-MOTIONLINK Plus-E) is subject to change without prior notice for performance improvement.

MEMO



Fast, Accurate, Smooth Motion

FASTECH Co., Ltd.

Rm#1202, 401-dong, Bucheon Techno-Park,
655, Pyeongcheon-ro, Bucheon-si Gyeonggi-do,
Republic of Korea (Postal Code: 14502)
TEL : +82-32-234-6317 FAX : +82-32-234-6302
E-mail : sales@fastech-motions.com
Homepage : www.fastech-motions.com