

Ezi-Robo®

Actuator series Driven by Ezi-SERVO

- Ezi-SERVO + Hollow Rotary Index Table
- Hollow Diameter : Max. Ø85mm
- Permissible Torque : Max. 170N·m
- Permissible Axial Load : Max. 4000N
- Repeatability : ±10arcsec
- EtherCAT, Ethernet, CC-Link Supported

HG

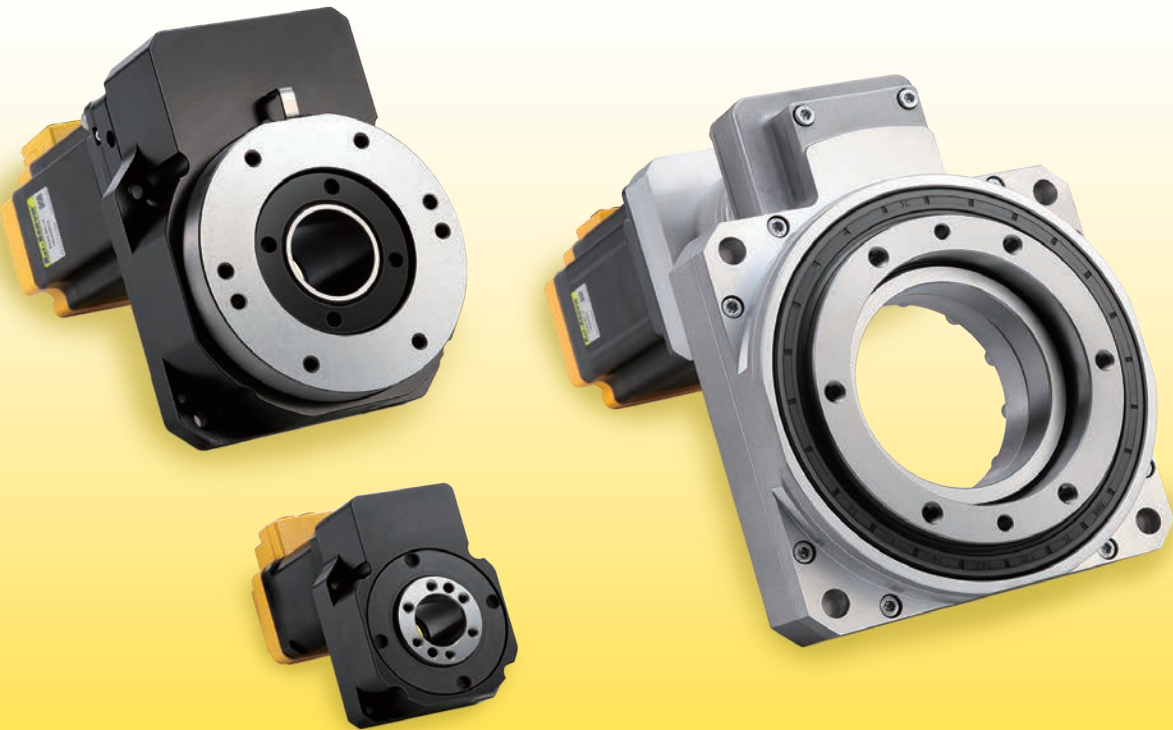

CE



FASTECH

Fast, Accurate, Smooth Motion

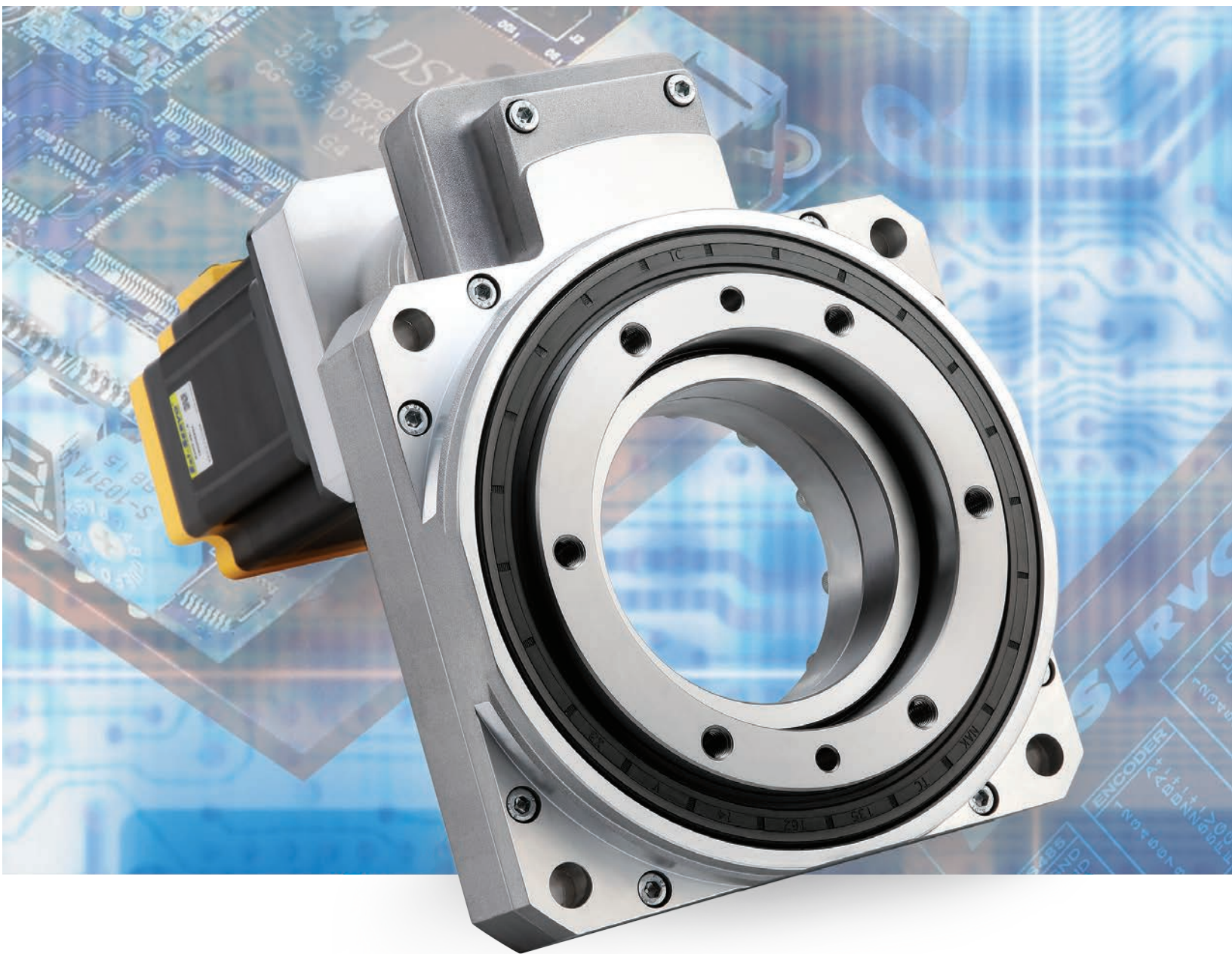

Fast, Accurate, Smooth Motion

Ezi-Robo[®] HG

Actuator series Driven by Ezi-SERVO

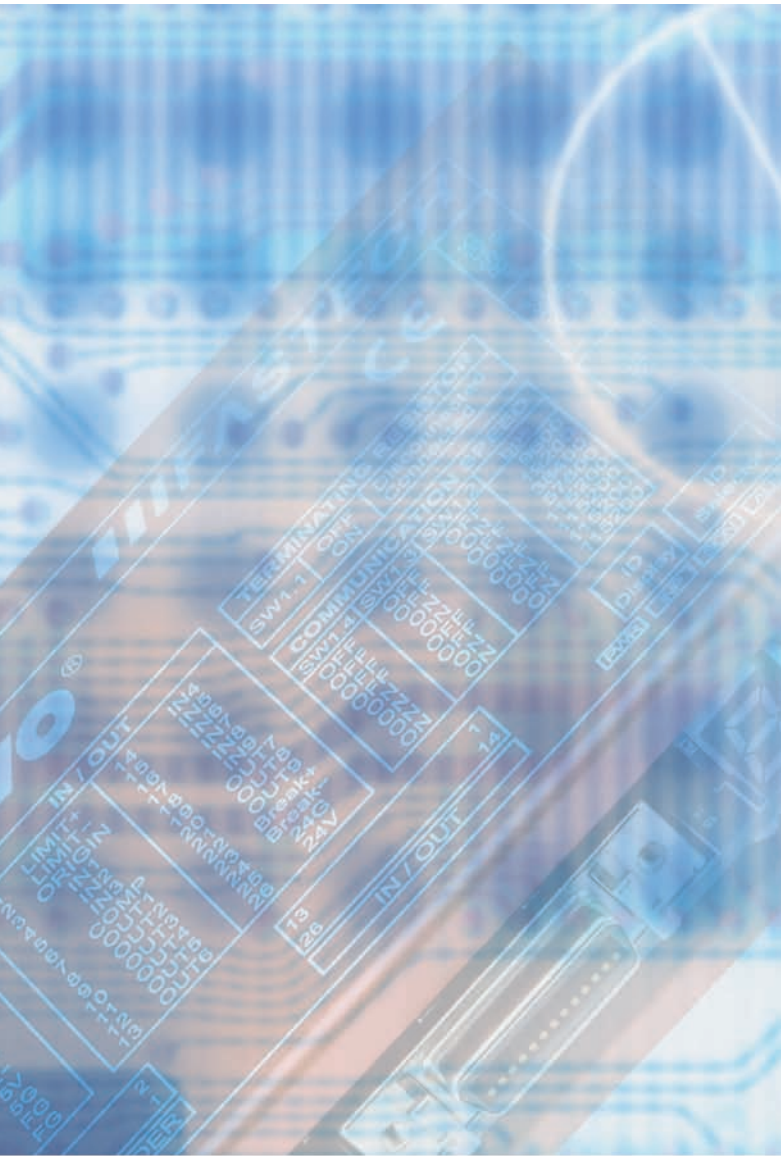

1 Large Diameter Hollow Rotary Actuator

The hollow rotary actuator is a product that integrates a hollow rotary index table and a stepping motor. The large-diameter hollow can be used for wiring and piping with complicated installation, providing flexibility and convenience when designing a machine.

| Model Name | Table Frame Size [mm] | Hollow Shaft [mm] |
|------------|-----------------------|-------------------|
| HG60 | 60 | Ø20 |
| HG100 | 100 | Ø29 |
| HG130S | 130 | Ø56 |
| HG170S | 170 | Ø85 |

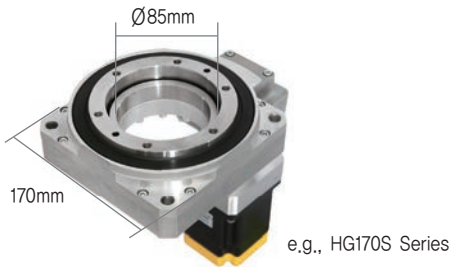

2 High Accuracy Position Control

Because Ezi-Robo HG uses gears with extremely low backlash, it has high repeatability and low lost motion, enabling high accuracy position control. Also, Ezi-Robo HG does not have mechanical parts such as belts and pulleys, there is no need to adjust belt tension, so maintenance is convenient and costs can be greatly reduced.

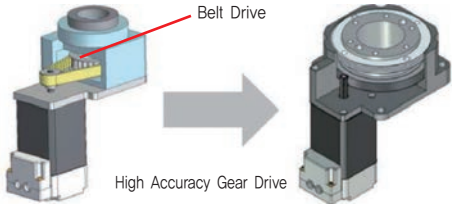

3 High Rigidity · High Load

The hollow rotary index table is integrated with a cross roller bearing to maximize the actuator's rigidity, so it can be applied to various applications requiring high rigidity.

- ※ For HG170S model
- Permissible Axial Load : 4000N
- Permissible Moment Load : 200N · m

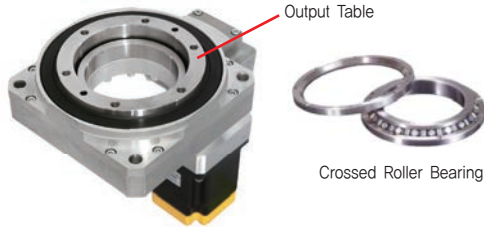

4 Simple Homing

A home sensor set is provided as an option to simplify the homing, which is often used in rotary index tables. This set includes all the parts necessary for homing, saving you the trouble of installing the home sensor.



5 Various Network Supported

Ezi-Robo HG is a unit product that combines a hollow rotary actuator and various drives, and can be connected to a host controller through field networks such as EtherCAT, Ethernet, and CC-Link.

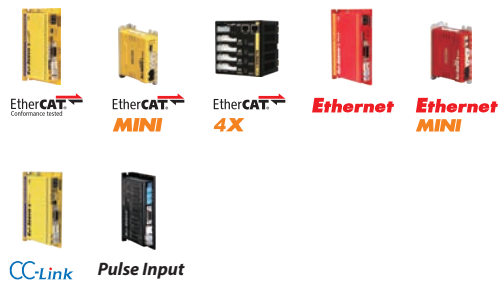

6 High Response

Similar to conventional stepping motors, Ezi-SERVO instantly synchronizes with command pulses providing fast positional response. Ezi-SERVO is the optimal choice when zero-speed stability and rapid motions within a short distance are required. Traditional servo motor systems have a natural delay called settling time between the command input signals and the resultant motion because of the constant monitoring of the current position.

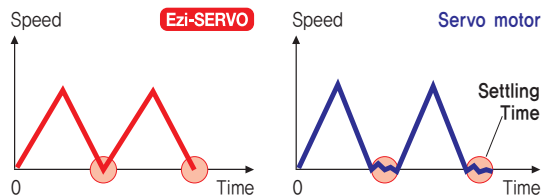

7 Tuning Not Required

To ensure machine performance, conventional servo systems require the adjustment of its servo's gains as an initial crucial step. Even systems that employ auto-tuning require manual tuning after the system is installed. Ezi-SERVO employs the best characteristics of the stepping motor to eliminate the need of tedious gain tuning required for conventional closed-loop servo systems. Ezi-Robo HG does not require gain tuning even with sudden load fluctuation or rapid acceleration because it is operated by Ezi-SERVO.

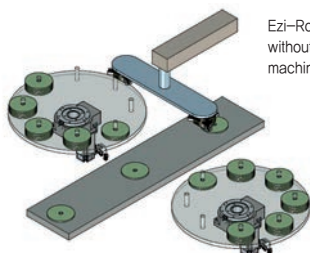

Ezi-Robo HG operates stably without gain tuning in the machine with load fluctuation.

8 No Hunting

Ezi-SERVO utilizes the unique characteristics of stepping motors and locks itself into the desired target position, preventing vibration and eliminating Null Hunt which happens to the conventional servo systems.

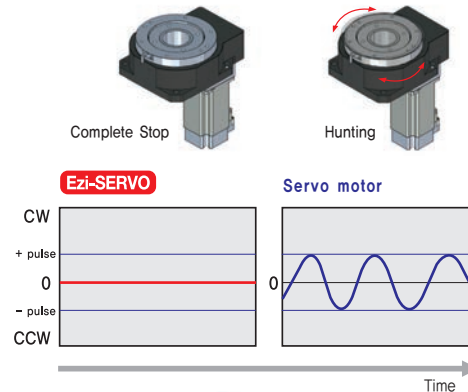

9 Position Table Function

Position Table can be used for motion control by digital input and output signals of host controller. You can operate the motor directly by sending the position table number, start/stop, origin search and other digital input values from a PC.

The PC can monitor the In-Position, origin search, moving/stop, servo ready and other digital output signals from a drive. A maximum of 256 positioning points can be set from PC.

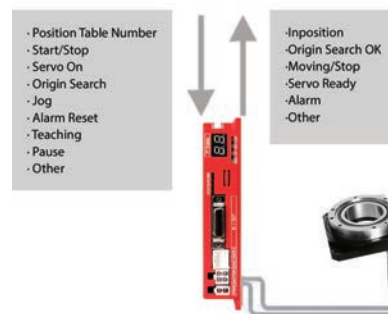

* For Ethernet, CC-Link series only.

10 High Torque

(Motor Voltage Increasing and Motor Current Setting)

Ezi-SERVO boosts the voltage supplied to the motor by internal DC-DC Converter. The torque at the high speed is increased. In addition, it is possible to set the Run Current up to 150%, whereby the torque at low speed is increased.

Torque can be improved by about 30% over the entire speed range.

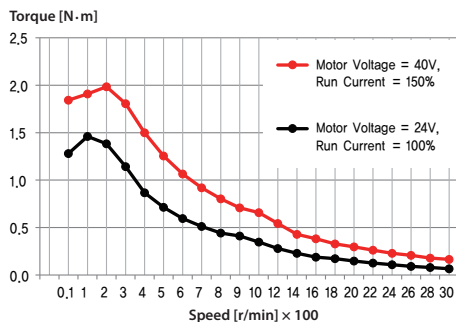

※ The torque at low speed and high speed is improved about 30%.

Measured Condition : Drive = Ezi-SERVO II-PE-56L
 Motor Voltage = DC40V
 Input Voltage = DC24V

12 Smooth and Accurate Operation

Ezi-SERVO is a high-precision servo drive, using a high-resolution encoder. Unlike a conventional Microstep drive, the on-board high performance MCU (Micro Controller Unit) performs vector control and filtering, producing a smooth rotational control with minimum ripples.

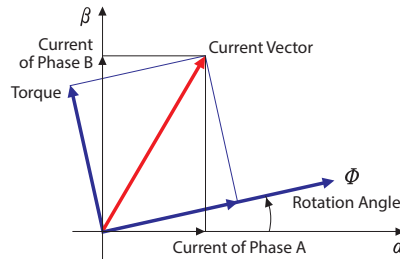

11 Low Heat Generation / Energy Savings

(Motor Current Control according to load)

Ezi-SERVO automatically controls motor current according to load.

Ezi-SERVO reduces motor current when motor load is low and increases motor current when load is high. By optimizing the motor current, motor heat can be minimized and energy can be saved.

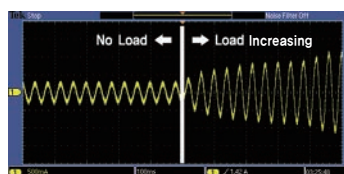
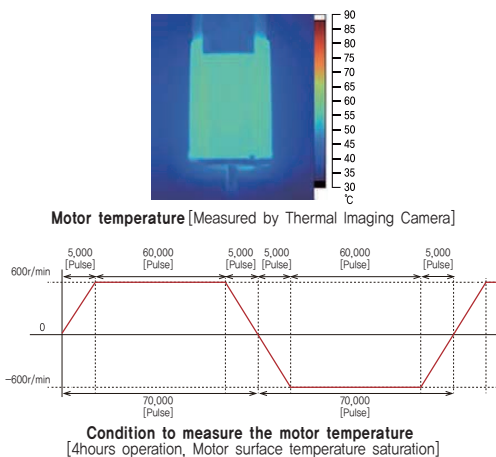

Example of the Motor Current Control according to load

13 Examples

| | |
|------------------------------------------------------------------|---------------------------------------------------|
| <p>Applications Subject to Changing Load Inertia</p> | <p>High Position Accuracy Applications</p> |
| <p>Applications Where a Moment Load is Applied</p> | <p>Optical Applications Using the Hollow Hole</p> |
| <p>High Position Accuracy Applications Using the Hollow Hole</p> | |

● Ezi-Robo HG Part Number

RB-HG130S-18-60L-EC

Product Name
 RB : Robot
 HG : Hollow Gearbox

Frame Size
 60 : 60mm
 100 : 100mm
 130 : 130mm
 170 : 170mm

Grade
 Blank : Standard Type
 S : Premium Type

Gear Ratio
 05 - 1:5
 08 - 1:8
 18 - 1:18
 20 - 1:20
 36 - 1:36

Motor Flange Size
 42 : 42mm
 60 : 60mm
 86 : 86mm

Motor Length
 L : Large
 XL : Extra Large

Drive Series
 EC : EtherCAT
 EC-MI : EtherCAT Mini Type
 EC-4X : EtherCAT 4 Axis Type
 PE : Plus Ethernet
 PE-MI : Plus Ethernet Mini Type
 CL : CC-Link
 ST : Pulse Input

● Applicable Product Series

| Product | Specifications |
|----------------------------|------------------------------------|
| Ezi-SERVO II EtherCAT | EtherCAT Based Product |
| Ezi-SERVO II EtherCAT MINI | EtherCAT Based Mini Type Product |
| Ezi-SERVO II EtherCAT 4X | EtherCAT Based 4 Axis Type Product |
| Ezi-SERVO II Plus-E | Ethernet Based Product |
| Ezi-SERVO II Plus-E MINI | Ethernet Based Mini Type Product |
| Ezi-SERVO II CC-Link | CC-Link Based Product |
| Ezi-SERVO ST | Pulse Input Type Product |



Ezi-SERVO II EtherCAT (EtherCAT)



Ezi-SERVO II EtherCAT MINI (EtherCAT Mini Type)



Ezi-SERVO II EtherCAT 4X (EtherCAT)



Ezi-SERVO II Plus-E (Ethernet)



Ezi-SERVO II Plus-E MINI (Ethernet Mini Type)



Ezi-SERVO II CC-Link (CC-Link)



Ezi-SERVO ST (Pulse Input Type)

● Combination of Actuator and Drive

| Unit Part Number | Gear Part Number | Motor Model Number | Drive Model Number | | | | | | |
|--------------------|------------------|--------------------|--------------------|-----------------------|----------------------------|--------------------------|---------------------|--------------------------|----------------------|
| | | | Ezi-SERVO ST | Ezi-SERVO II EtherCAT | Ezi-SERVO II EtherCAT MINI | Ezi-SERVO II EtherCAT 4X | Ezi-SERVO II Plus-E | Ezi-SERVO II Plus-E MINI | Ezi-SERVO II CC-Link |
| RB-HG60-05-42XL-□ | HG60-05 | EzM2-42XL-A | ○ | ○ | ○ | ○ | ○ | ○ | ○ |
| RB-HG100-08-60L-□ | HG100-08 | EzM2-60L-A | ○ | ○ | ○ | ○ | ○ | ○ | ○ |
| RB-HG130S-18-60L-□ | HG130S-18 | EzM2-60L-A | ○ | ○ | ○ | ○ | ○ | ○ | ○ |
| RB-HG170S-20-60L-□ | HG170S-20 | EzM2-60L-A | ○ | ○ | ○ | ○ | ○ | ○ | ○ |
| RB-HG170S-36-60L-□ | HG170S-36 | EzM2-60L-A | ○ | ○ | ○ | ○ | ○ | ○ | ○ |
| RB-HG170S-20-86L-□ | HG170S-20 | EzM2-86L-A | ● | ● | | | ● | | ● |
| RB-HG170S-36-86L-□ | HG170S-36 | EzM2-86L-A | ● | ● | | | ● | | ● |

※ □ is a type of a drive,

● is for 86mm drives,

● How to Read Specifications

| Model Name | | RB-HG60-05-42XL |
|-------------------------------------------------|----------------------|--------------------------|
| ① Output Table Supporting Bearing | | Ball Bearing |
| ② Permissible Torque | [N·m] | 4.5 |
| ③ Inertia Moment | [kg·m ²] | 2,330 × 10 ⁻⁷ |
| ④ Permissible Speed | [r/min] | 300 |
| ⑤ Gear Ratio | | 1:5 |
| ⑥ Holding Torque* ¹ | [N·m] | 2.2 |
| ⑦ Repeatability | [arcsec] | ±10(±0.0028°) |
| ⑧ Lost Motion | [arcmin] | 2(0.033°) |
| ⑨ Angular Transmission Accuracy | [arcmin] | 4(0.067°) |
| ⑩ Permissible Axial Load | [N] | 100 |
| ⑪ Permissible Moment Load | [N·m] | 2 |
| ⑫ Runout of Output Table Surface | [mm] | 0.015 |
| ⑬ Runout of Output Table Inner (Outer) Diameter | [mm] | 0.015 |
| ⑭ Parallelism of Output Table | [mm] | 0.03 |
| ⑮ Degree of Protection* ² | | P40 |
| ⑯ Mass of Actuator Unit | [kg] | 1.6 |

*1 : When Stop Current is 100%

*2 : IP20 for motor connector

Description of Specification Items

| No. | Item | Description |
|-----|----------------------------------------------------|--------------------------------------------------------------------------------------------------------------------------------------------------------------------------------------------------------------------------------------------------------------------------|
| ① | Output Table Supporting Bearing | The type of the bearing used for the output table. |
| ② | Permissible Torque [N·m] | This is the maximum torque that can be applied to the gear output shaft during acceleration/deceleration. |
| ③ | Inertia Moment [kg·m ²] | The total sum of the rotor inertial moment of the motor and the inertial moment of the speed reduction mechanism converted to a moment on the output table. |
| ④ | Permissible Speed [r/min] | The output table speed that can be tolerated by the mechanical strength of the speed reduction mechanism. |
| ⑤ | Gear Ratio | The rate at which the actuator reduces the rotation speed of the motor. |
| ⑥ | Holding Torque [N·m] | The maximum torque with which to hold the output table in position if it stops while the power is still on. |
| ⑦ | Repeatability [arcsec] | A value indicating the degree of error that generates when positioning is performed repeatedly to the same position in the same direction. |
| ⑧ | Lost Motion [arcmin] | The difference between stopped angles achieved when the output table is positioned to the same position in the forward and reverse directions |
| ⑨ | Angular Transmission Accuracy [arcmin] | The difference between the theoretical rotation angle of the output table as calculated from the input pulse counter, and the actual rotation angle. |
| ⑩ | Permissible Axial Load [N] | The permissible value of thrust load applied to the output table in the axial direction. |
| ⑪ | Permissible Moment Load [N·m] | When a load is applied to a position away from the center of the output table, the output table receives a tilting force. The permissible moment load refers to the permissible value of moment load calculated by the eccentricity from the center by the applied load. |
| ⑫ | Runout of Output Table Surface [mm] | The max. value of runout of the installation surface of the output table when the output table is rotated under no load. |
| ⑬ | Runout of Output Table Inner (Outer) Diameter [mm] | The max. value of runout of the inner diameter or outer diameter of the table when the output table is rotated under no load. |
| ⑭ | Parallelism of Output Table [mm] | The inclination of the installation surface of the output table compared with the actuator installation surface on the equipment side. |
| ⑮ | Degree of Protection | Based on IEC60529 and EN60034-5 (=IEC60034-5), dust resistance and waterproofing regarding the degree of protection of the device is classified using a grade. |
| ⑯ | Mass of Actuator Unit [kg] | The total weight of all parts, including the output table, reduction mechanism, motor and so on that make up the actuator. |

● Specifications [HG60 Series]

| | | |
|-----------------------------------------------|----------------------|----------------------------|
| Model Name | RB-HG60-05-42XL | |
| Output Table Supporting Bearing | Ball Bearing | |
| Permissible Torque | [N·m] | 4.5 |
| Inertia Moment | [kg·m ²] | $2,330 \times 10^{-7}$ |
| Permissible Speed | [r/min] | 300 |
| Gear Ratio | 1:5 | |
| Holding Torque ^{*1} | [N·m] | 2.2 |
| Repeatability | [arcsec] | $\pm 10(\pm 0.0028^\circ)$ |
| Lost Motion | [arcmin] | 2(0.033°) |
| Angular Transmission Accuracy | [arcmin] | 4(0.067°) |
| Permissible Axial Load | [N] | 100 |
| Permissible Moment Load | [N·m] | 2 |
| Runout of Output Table Surface | [mm] | 0.03 |
| Runout of Output Table Inner (Outer) Diameter | [mm] | 0.03 |
| Parallelism of Output Table | [mm] | 0.05 |
| Degree of Protection ^{*2} | IP40 | |
| Mass of Actuator Unit | [kg] | 1.6 |

*1 : When Stop Current is 100%

*2 : IP20 for motor connector

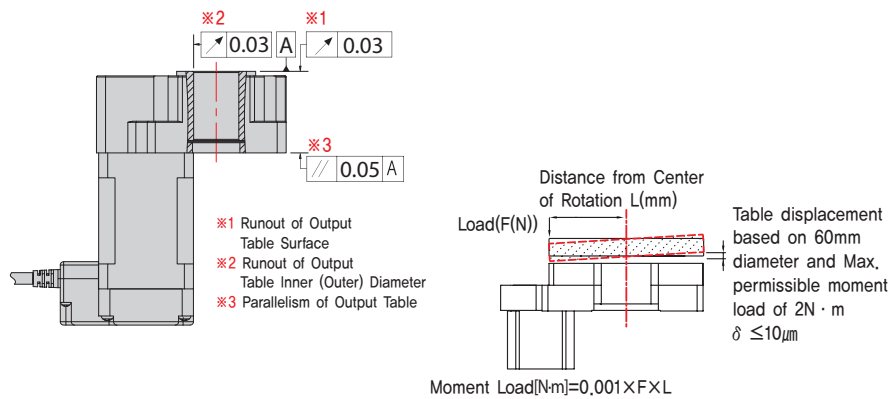

Applicable Model

40V

Ezi-SERVO II EtherCAT

Ezi-SERVO II Plus-E

Ezi-SERVO II CC-Link

Ezi-SERVO ST

24V

Ezi-SERVO II EtherCAT MINI

Ezi-SERVO II EtherCAT 4X

Ezi-SERVO II Plus-E MINI

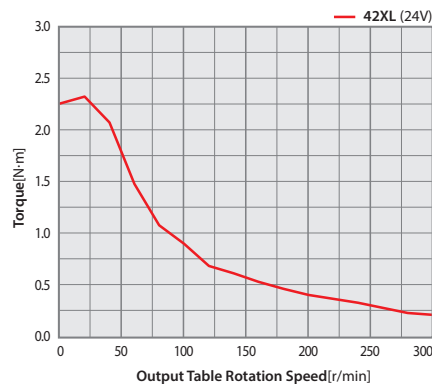
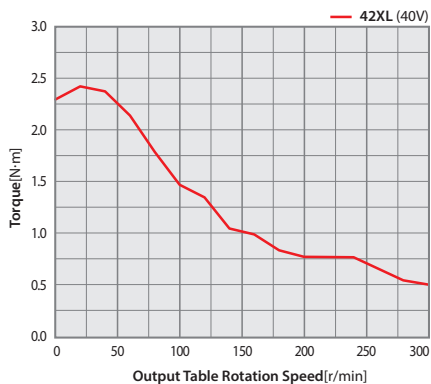

● Specifications [HG100 Series]

| | | |
|-----------------------------------------------|---------------------------------------|------------------------|
| Model Name | RB-HG100-08-60L | |
| Output Table Supporting Bearing | Tapered Roller Bearing + Ball Bearing | |
| Permissible Torque | [N·m] | 12 |
| Inertia Moment | [kg·m ²] | 3,898×10 ⁻⁶ |
| Permissible Speed | [r/min] | 200 |
| Gear Ratio | 1:8 | |
| Holding Torque ^{*1} | [N·m] | 12 |
| Repeatability | [arcsec] | ±10(0,0028°) |
| Lost Motion | [arcmin] | 2(0,033°) |
| Angular Transmission Accuracy | [arcmin] | 4(0,067°) |
| Permissible Axial Load | [N] | 500 |
| Permissible Moment Load | [N·m] | 10 |
| Runout of Output Table Surface | [mm] | 0,015 |
| Runout of Output Table Inner (Outer) Diameter | [mm] | 0,015 |
| Parallelism of Output Table | [mm] | 0,03 |
| Degree of Protection ^{*2} | IP40 | |
| Mass of Actuator Unit | [kg] | 4,0 |

*1 : When Stop Current is 100%

*2 : IP20 for motor connector

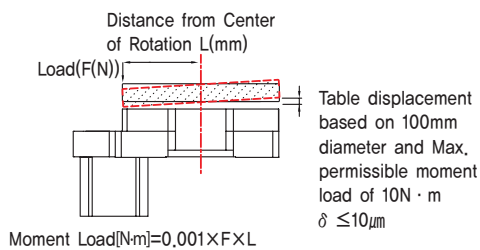
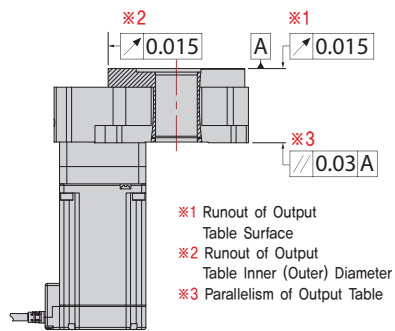

FASTECH Ezi-Robo HG

Applicable Model

40V

| | | | |
|-----------------------|---------------------|----------------------|--------------|
| Ezi-SERVO II EtherCAT | Ezi-SERVO II Plus-E | Ezi-SERVO II CC-Link | Ezi-SERVO ST |
|-----------------------|---------------------|----------------------|--------------|

24V

| | | | |
|----------------------------|--------------------------|--------------------------|--|
| Ezi-SERVO II EtherCAT MINI | Ezi-SERVO II EtherCAT 4X | Ezi-SERVO II Plus-E MINI | |
|----------------------------|--------------------------|--------------------------|--|

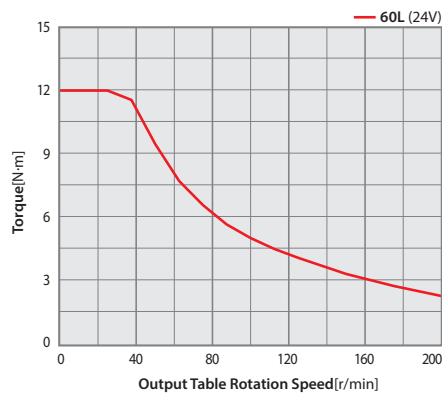
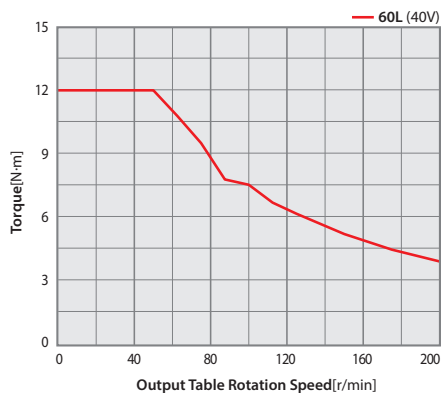

● Specifications [HG130S Series]

| | | |
|-----------------------------------------------|------------------------|------------------------|
| Model Name | RB-HG130S-18-60L | |
| Output Table Supporting Bearing | Crossed Roller Bearing | |
| Permissible Torque | [N·m] | 34 |
| Inertia Moment | [kg·m ²] | 3,127×10 ⁻⁵ |
| Permissible Speed | [r/min] | 200 |
| Gear Ratio | 1:18 | |
| Holding Torque* ¹ | [N·m] | 25,1 |
| Repeatability | [arcsec] | ±10(0,0028°) |
| Lost Motion | [arcmin] | 2(0,033°) |
| Angular Transmission Accuracy | [arcmin] | 4(0,067°) |
| Permissible Axial Load | [N] | 2,000 |
| Permissible Moment Load | [N·m] | 50 |
| Runout of Output Table Surface | [mm] | 0,07 |
| Runout of Output Table Inner (Outer) Diameter | [mm] | 0,04 |
| Parallelism of Output Table | [mm] | 0,07 |
| Degree of Protection* ² | IP40 | |
| Mass of Actuator Unit | [kg] | 6,3 |

*¹ : When Stop Current is 100%

*² : IP20 for motor connector

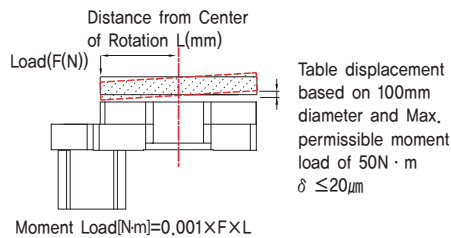
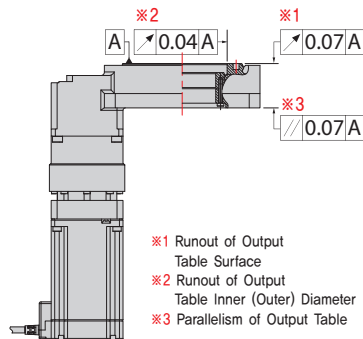

Applicable Model

40V

Ezi-SERVO II EtherCAT

Ezi-SERVO II Plus-E

Ezi-SERVO II CC-Link

Ezi-SERVO ST

24V

Ezi-SERVO II EtherCAT MINI

Ezi-SERVO II EtherCAT 4X

Ezi-SERVO II Plus-E MINI

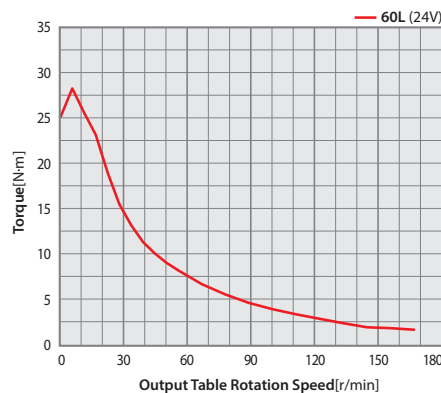
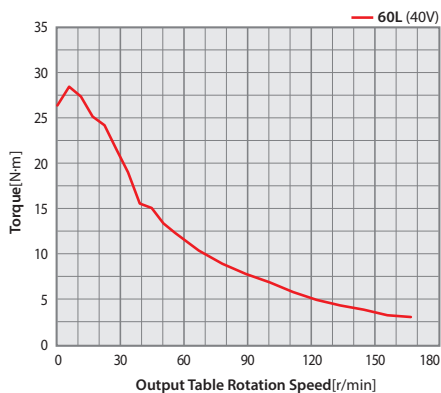

● Specifications [HG170S Series (Gear Ratio 1:20)]

| | | |
|-----------------------------------------------|------------------------|------------------------|
| Model Name | RB-HG170S-20-60L | |
| Output Table Supporting Bearing | Crossed Roller Bearing | |
| Permissible Torque | [N·m] | 170 |
| Inertia Moment | [kg·m ²] | 4,752×10 ⁻⁵ |
| Permissible Speed | [r/min] | 150 |
| Gear Ratio | 1:20 | |
| Holding Torque ^{*1} | [N·m] | 27.8 |
| Repeatability | [arcsec] | ±10(0,0028°) |
| Lost Motion | [arcmin] | 2(0,033°) |
| Angular Transmission Accuracy | [arcmin] | 4(0,067°) |
| Permissible Axial Load | [N] | 3,900 |
| Permissible Moment Load | [N·m] | 152 |
| Runout of Output Table Surface | [mm] | 0,07 |
| Runout of Output Table Inner (Outer) Diameter | [mm] | 0,04 |
| Parallelism of Output Table | [mm] | 0,07 |
| Degree of Protection ^{*2} | IP40 | |
| Mass of Actuator Unit | [kg] | 8,7 |

*1 : When Stop Current is 100%

*2 : IP20 for motor connector

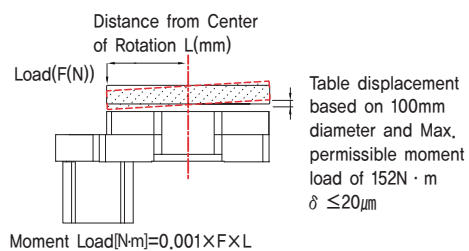
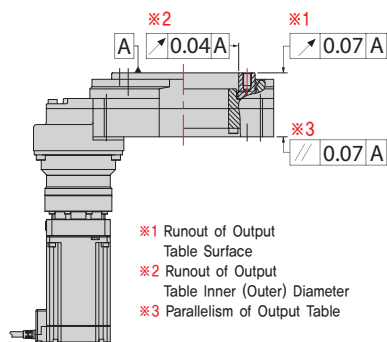

Applicable Model

40V

Ezi-SERVO II EtherCAT

Ezi-SERVO II Plus-E

Ezi-SERVO II CC-Link

Ezi-SERVO ST

24V

Ezi-SERVO II EtherCAT MINI

Ezi-SERVO II EtherCAT 4X

Ezi-SERVO II Plus-E MINI

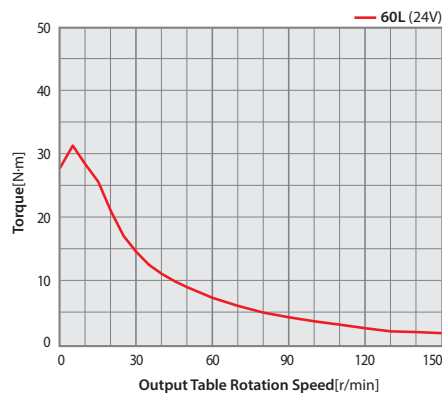
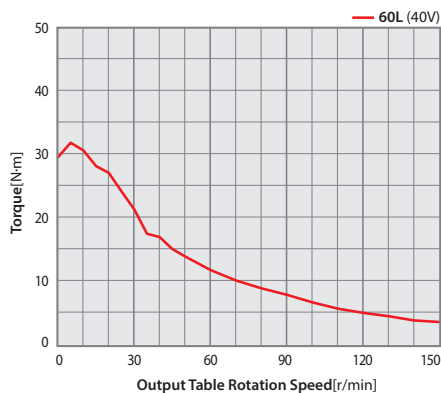

● Specifications [HG170S Series (Gear Ratio 1:20)]

| | | |
|-----------------------------------------------|------------------------|------------------------|
| Model Name | RB-HG170S-20-86L | |
| Output Table Supporting Bearing | Crossed Roller Bearing | |
| Permissible Torque | [N·m] | 170 |
| Inertia Moment | [kg·m ²] | 7,484×10 ⁻⁵ |
| Permissible Speed | [r/min] | 150 |
| Gear Ratio | 1:20 | |
| Holding Torque ^{*1} | [N·m] | 96,1 |
| Repeatability | [arcsec] | ±10(0,0028°) |
| Lost Motion | [arcmin] | 2(0,033°) |
| Angular Transmission Accuracy | [arcmin] | 4(0,067°) |
| Permissible Axial Load | [N] | 3,900 |
| Permissible Moment Load | [N·m] | 152 |
| Runout of Output Table Surface | [mm] | 0,07 |
| Runout of Output Table Inner (Outer) Diameter | [mm] | 0,04 |
| Parallelism of Output Table | [mm] | 0,07 |
| Degree of Protection ^{*2} | IP40 | |
| Mass of Actuator Unit | [kg] | 11,9 |

*1 : When Stop Current is 100%

*2 : IP20 for motor connector

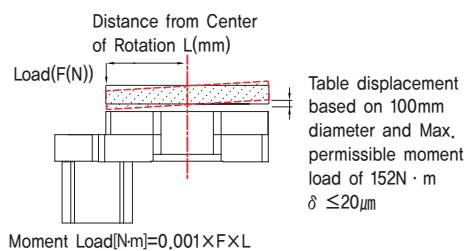
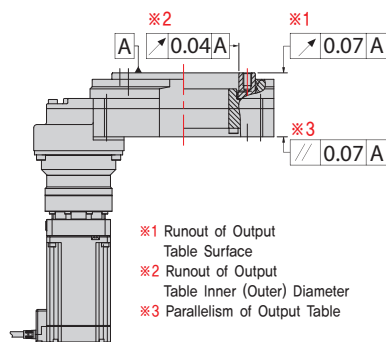

Applicable Model

70V

| | | | |
|-----------------------|---------------------|----------------------|--------------|
| Ezi-SERVO II EtherCAT | Ezi-SERVO II Plus-E | Ezi-SERVO II CC-Link | Ezi-SERVO ST |
|-----------------------|---------------------|----------------------|--------------|

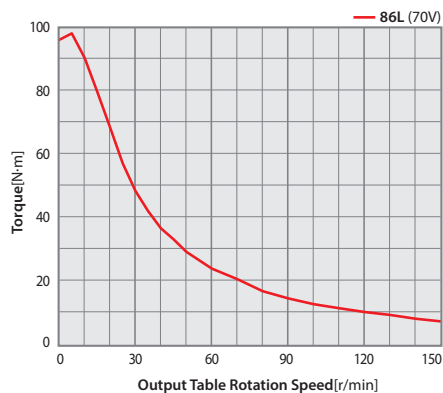

● Specifications [HG170S Series (Gear Ratio 1:36)]

| | | |
|-----------------------------------------------|------------------------|-------------------------|
| Model Name | RB-HG170S-36-60L | |
| Output Table Supporting Bearing | Crossed Roller Bearing | |
| Permissible Torque | [N·m] | 107 |
| Inertia Moment | [kg·m ²] | 12,351×10 ⁻⁵ |
| Permissible Speed | [r/min] | 150 |
| Gear Ratio | 1:36 | |
| Holding Torque ^{*1} | [N·m] | 50,2 |
| Repeatability | [arcsec] | ±10(0,0028°) |
| Lost Motion | [arcmin] | 2(0,033°) |
| Angular Transmission Accuracy | [arcmin] | 4(0,067°) |
| Permissible Axial Load | [N] | 4,000 |
| Permissible Moment Load | [N·m] | 200 |
| Runout of Output Table Surface | [mm] | 0,07 |
| Runout of Output Table Inner (Outer) Diameter | [mm] | 0,04 |
| Parallelism of Output Table | [mm] | 0,07 |
| Degree of Protection ^{*2} | IP40 | |
| Mass of Actuator Unit | [kg] | 8,7 |

*1 : When Stop Current is 100%

*2 : IP20 for motor connector

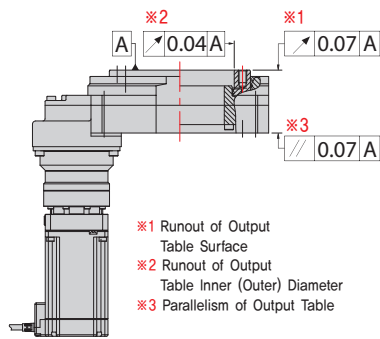

- *1 Runout of Output Table Surface
- *2 Runout of Output Table Inner (Outer) Diameter
- *3 Parallelism of Output Table

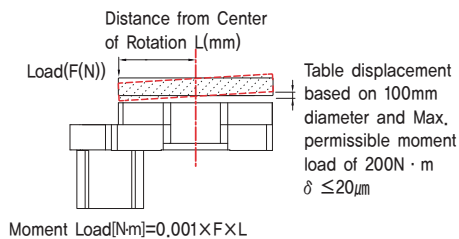

Applicable Model

40V

| | | | |
|-----------------------|---------------------|----------------------|--------------|
| Ezi-SERVO II EtherCAT | Ezi-SERVO II Plus-E | Ezi-SERVO II CC-Link | Ezi-SERVO ST |
|-----------------------|---------------------|----------------------|--------------|

24V

| | | | |
|----------------------------|--------------------------|--------------------------|--|
| Ezi-SERVO II EtherCAT MINI | Ezi-SERVO II EtherCAT 4X | Ezi-SERVO II Plus-E MINI | |
|----------------------------|--------------------------|--------------------------|--|

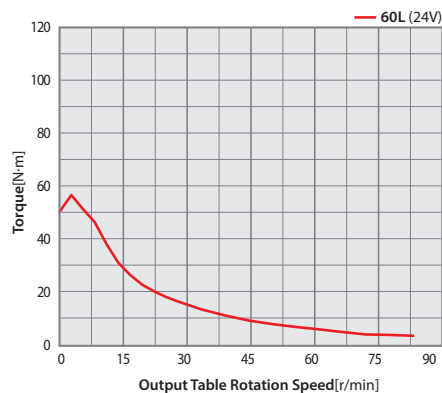
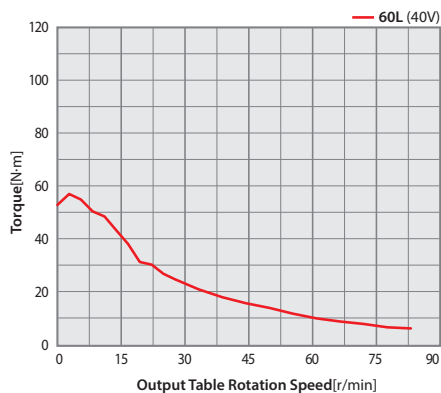

● Specifications [HG170S Series (Gear Ratio 1:36)]

| | | |
|-----------------------------------------------|------------------------|-------------------------|
| Model Name | RB-HG170S-36-86L | |
| Output Table Supporting Bearing | Crossed Roller Bearing | |
| Permissible Torque | [N·m] | 107 |
| Inertia Moment | [kg·m ²] | 21,203×10 ⁻⁵ |
| Permissible Speed | [r/min] | 150 |
| Gear Ratio | 1:36 | |
| Holding Torque* ¹ | [N·m] | 107 |
| Repeatability | [arcsec] | ±10(0,0028°) |
| Lost Motion | [arcmin] | 2(0,033°) |
| Angular Transmission Accuracy | [arcmin] | 4(0,067°) |
| Permissible Axial Load | [N] | 4,000 |
| Permissible Moment Load | [N·m] | 200 |
| Runout of Output Table Surface | [mm] | 0,07 |
| Runout of Output Table Inner (Outer) Diameter | [mm] | 0,04 |
| Parallelism of Output Table | [mm] | 0,07 |
| Degree of Protection* ² | IP40 | |
| Mass of Actuator Unit | [kg] | 11,9 |

*¹ : When Stop Current is 100%

*² : IP20 for motor connector

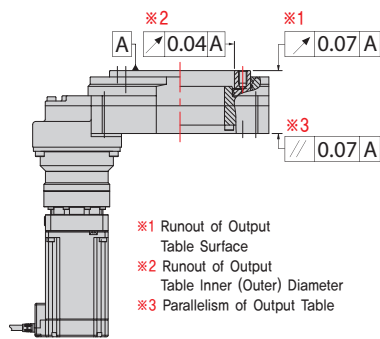

- ※1 Runout of Output Table Surface
- ※2 Runout of Output Table Inner (Outer) Diameter
- ※3 Parallelism of Output Table

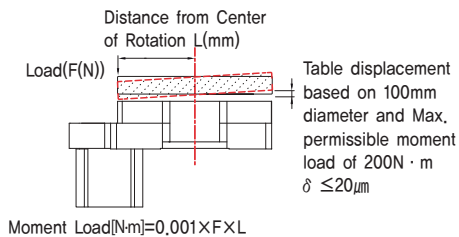

Applicable Model

70V

Ezi-SERVO II EtherCAT

Ezi-SERVO II Plus-E

Ezi-SERVO II CC-Link

Ezi-SERVO ST

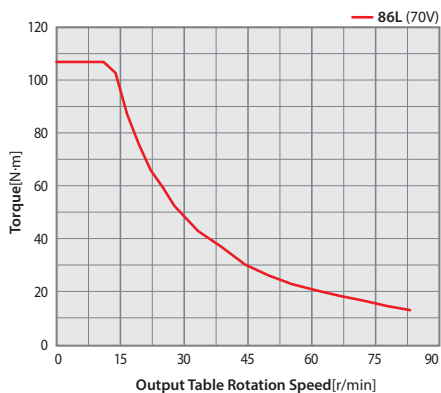

● Dimensions of Product [mm]

RB-HG60-05-42XL-□

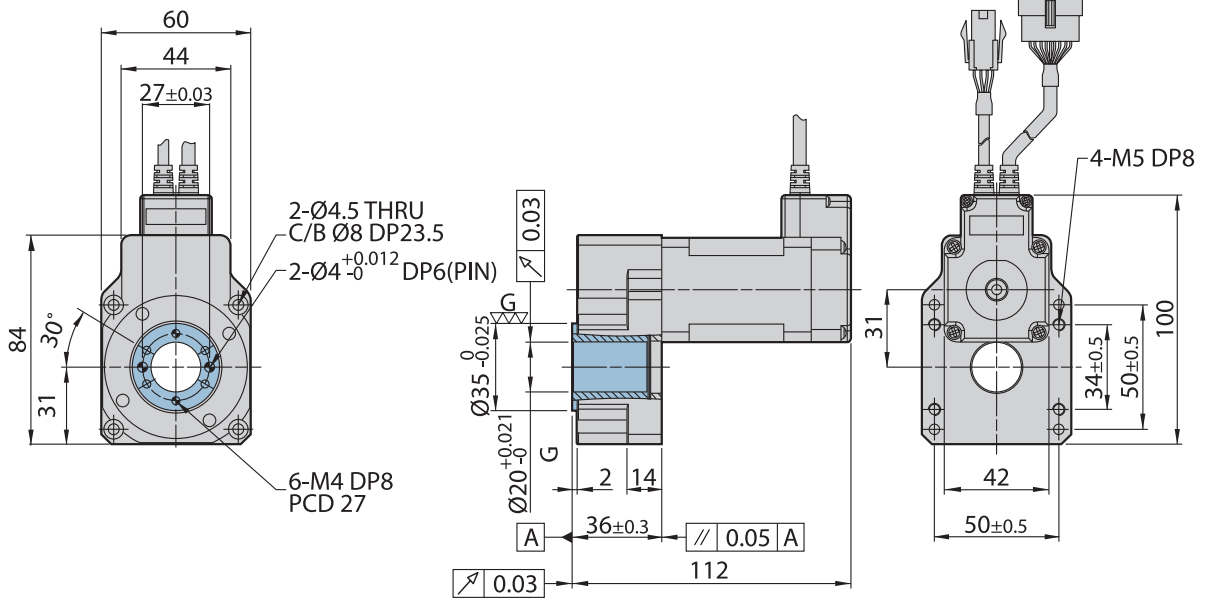

※ □ is a drive type.

FASTECH Ezi-Robo HG

RB-HG100-08-60L-□

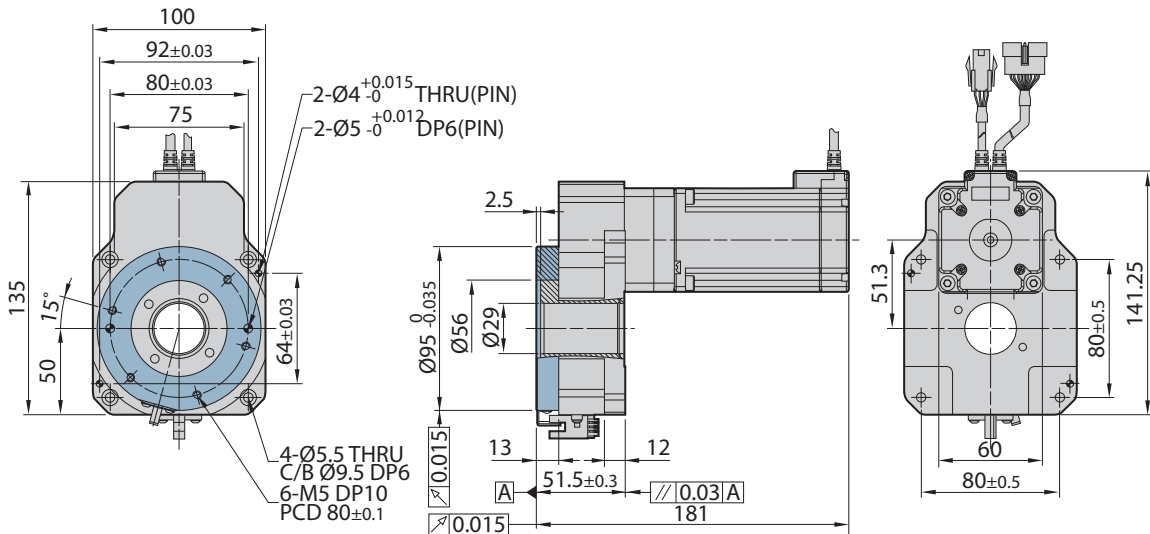

※ □ is a drive type.

● Dimensions of Product [mm]

RB-HG130S-18-60L-□

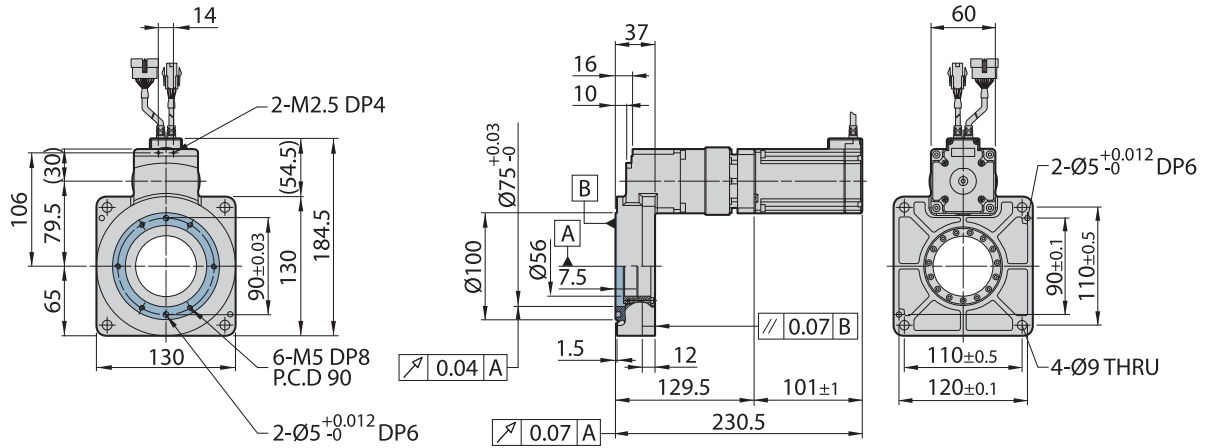

※ □ is a drive type.

RB-HG170S-20-60L-□
RB-HG170S-36-60L-□

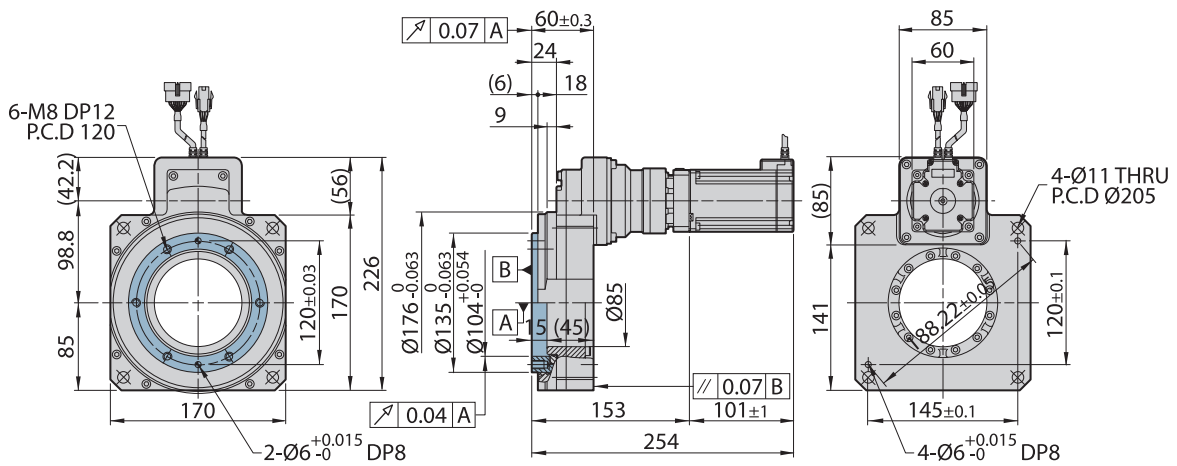

※ □ is a drive type.

● Dimensions of Product [mm]

RB-HG170S-20-86L-□
RB-HG170S-36-86L-□

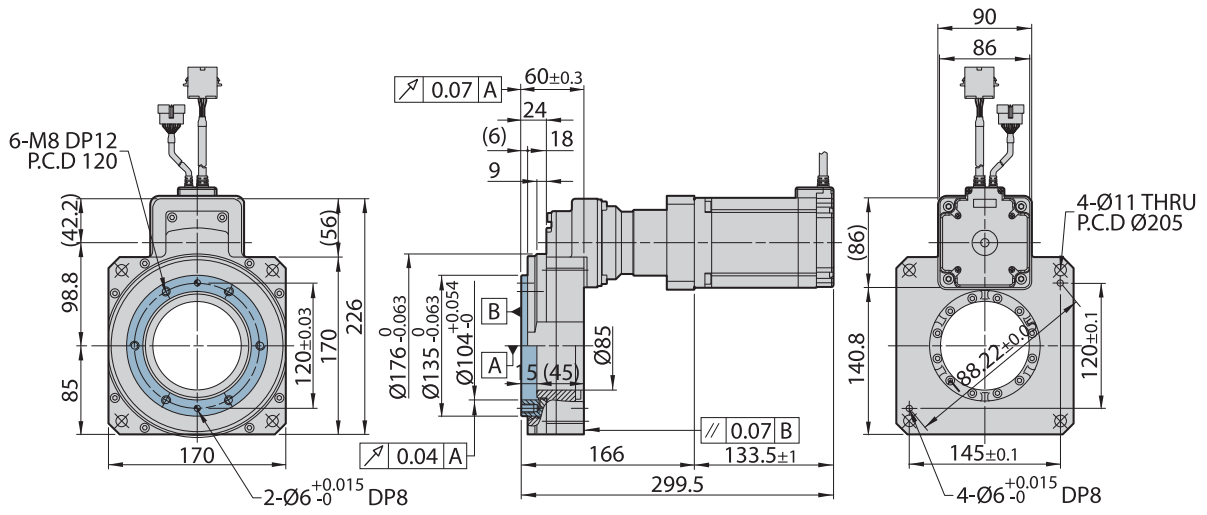

※ □ is a drive type.

● Home Sensor Set

1. Type

| Part Number | Sensor Output | Applicable Product |
|-------------|---------------|-----------------------------|
| OSHG-A | NPN | HG60, HG100, HG130S, HG170S |
| OSHG-AY | PNP | |

2. Components (OSHG-A)



3. Specifications

| Type | NPN Type | PNP Type |
|----------------------|----------------------------------------------------------------------------------------------------------------|----------------------------------------------------------------------------------------------------------------|
| Sensor Part Number | EE-SX672A(OMRON Product) | EE-SX672R(OMRON Product) |
| Power Supply Voltage | DC5~24V±10%, Ripple (P-P) 10% or less | DC5~24V±10%, Ripple (P-P) 10% or less |
| Current Consumption | 35mA or less | 30mA or less |
| Control Output | NPN Open-Collector Output DC5~24V 100mA or less Residual Voltage 0.8V or less (Load current of 100mA) | PNP Open-Collector Output DC5~24V 100mA or less Residual Voltage 1.3V or less (Load current of 100mA) |
| Indicator LED | Detection Display (Red) | Detection Display (Red) |
| Sensor Logic | Normally Open / Normally Closed (Selectable depending on connection) | Normally Open / Normally Closed (Selectable depending on connection) |

4. Cable with Connector(OMRON Robot Code Attached Connector EE1010-R)

· Terminal Layout

| | | |
|---|-----|-------|
| ① | ⊕ | Brown |
| ② | L | Pink |
| ③ | OUT | Black |
| ④ | ⊖ | Blue |

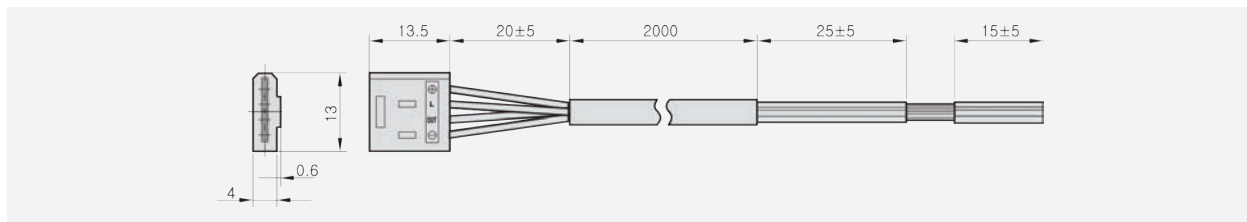

5. When Installing the Home Sensor Set

· Set the operating conditions so that the operating ambient temperature stays under 40°C, and the surface temperature of the actuator motor stays under 90°C.

6. When Extending the Sensor Cable

Use shielded cable when extending the sensor cable 2 m or more, and the cable must be grounded.

● Home Sensor Cable Installation

1. NPN Type

· With User's Controller

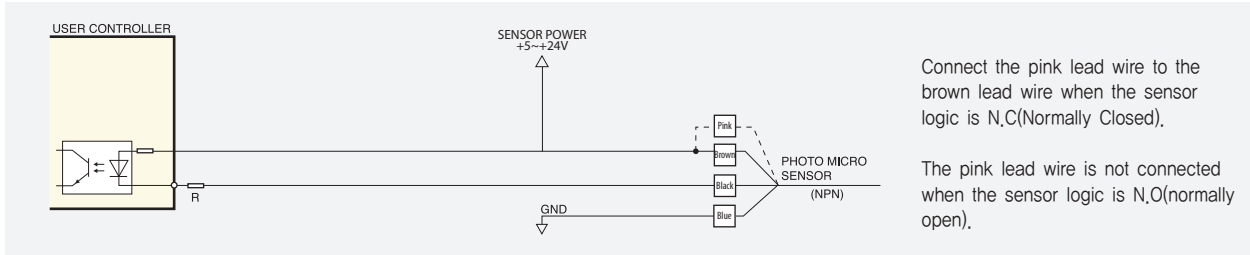

The power supply voltage for the sensor is DC5~24V, and the signal current of the sensor can be used up to 50mA. For details, refer to the controller specifications for wiring. If the signal current of the sensor exceeds the current range of the controller or sensor, connect a current limiting resistor (R).

· With Embedded Motion Controller Type Products (e.g., Ezi-SERVOII Plus-E)

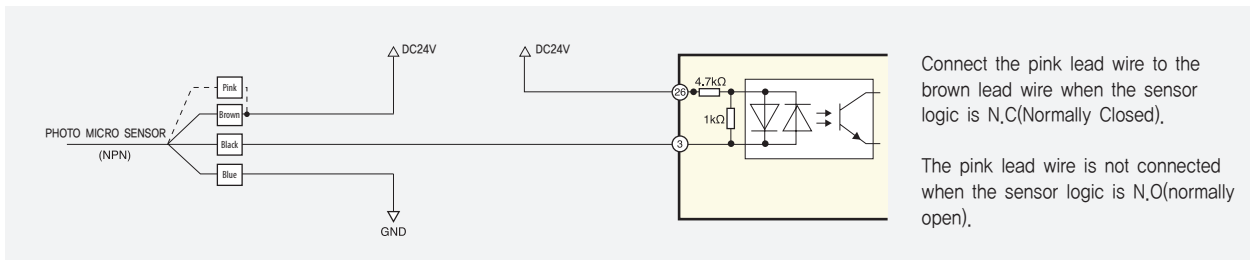

2. PNP Type

· With User's Controller

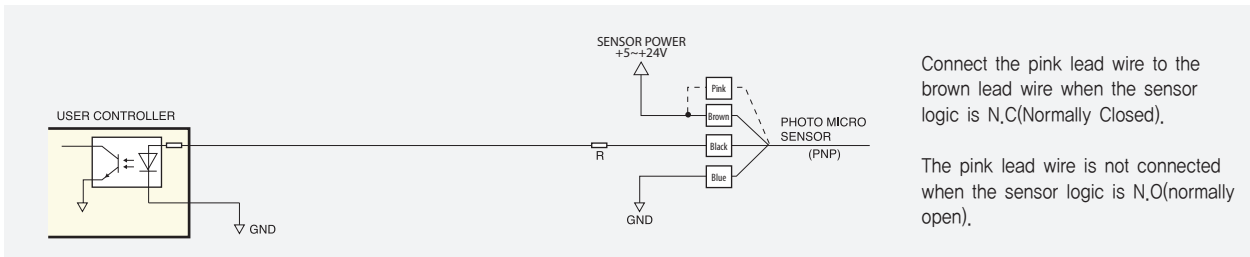

The power supply voltage for the sensor is DC5~24V, and the signal current of the sensor can be used up to 50mA. For details, refer to the controller specifications for wiring. If the signal current of the sensor exceeds the current range of the controller or sensor, connect a current limiting resistor (R).

· With Embedded Motion Controller Type Products (e.g., Ezi-SERVOII Plus-E)

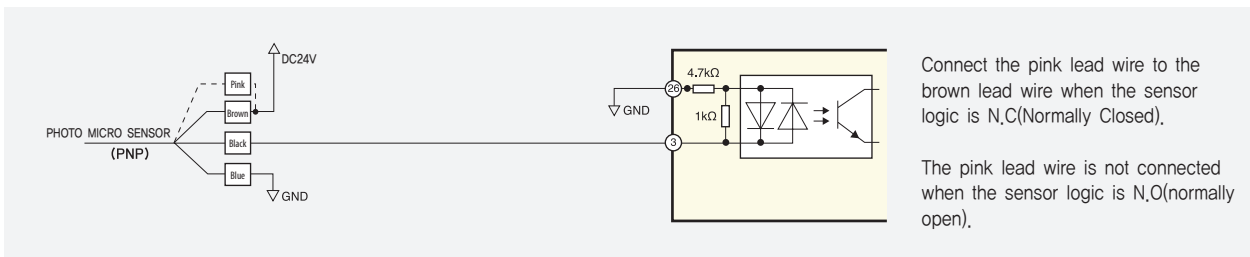

● System Configuration [EtherCAT (Ezi-SERVO II EtherCAT)]

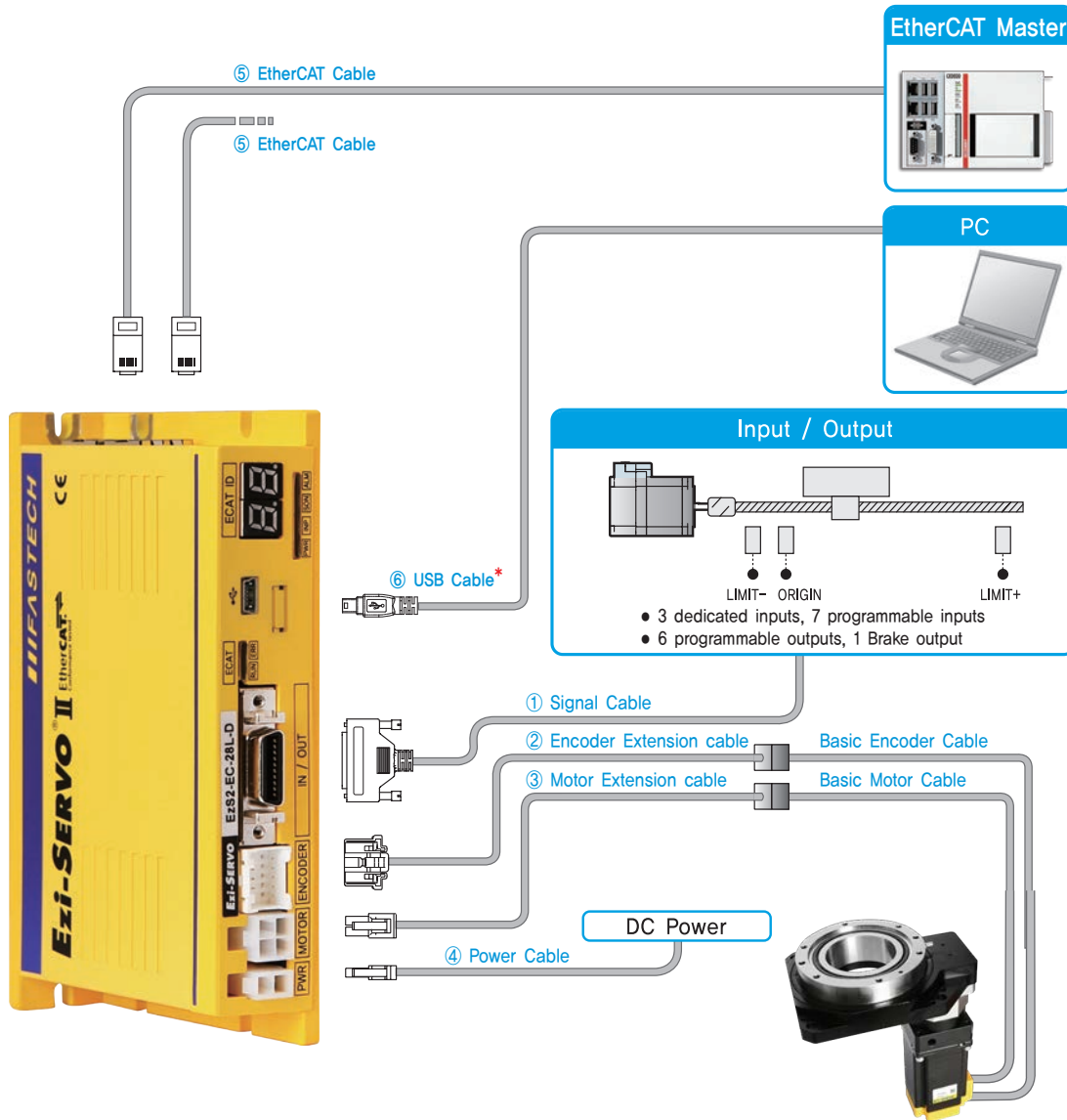

| Cable Type | Max. Length | Remarks |
|---------------------------|---------------------|-------------------------------------------------------------------------------------------------------------|
| ① Signal Cable | 20m | Options (Sold separately) |
| ② Encoder Extension Cable | 20m | |
| ③ Motor Extension Cable | 20m | |
| ④ Power Cable | 2m | |
| ⑤ EtherCAT Cable | 100m | Basic cables are attached to motors. |
| Basic Encoder Cable | 0,3m (Basic length) | |
| Basic Motor Cable | 0,3m (Basic length) | |
| USB Cable | 5m | * USB cables are not provided by FASTECH. We recommend using a standard USB cable (USB 2,0 Mini Type B). |

- Ezi-SERVO II EtherCAT is stepping motor control system using EtherCAT, high speed ethernet (100Mbps Full-Duplex) based fieldbus. Ezi-SERVO II EtherCAT is EtherCAT slave module which supports CAN application layer over EtherCAT (CoE). It employs CiA 402 Drive Profile and supports Profile Position Mode, Homing Mode, Cyclic Synchronous Position Mode.
- Please refer to Ezi-SERVO II EtherCAT catalog for more detailed information about Ezi-SERVO II EtherCAT drive.

● System Configuration [EtherCAT (Ezi-SERVO II EtherCAT 86mm)]

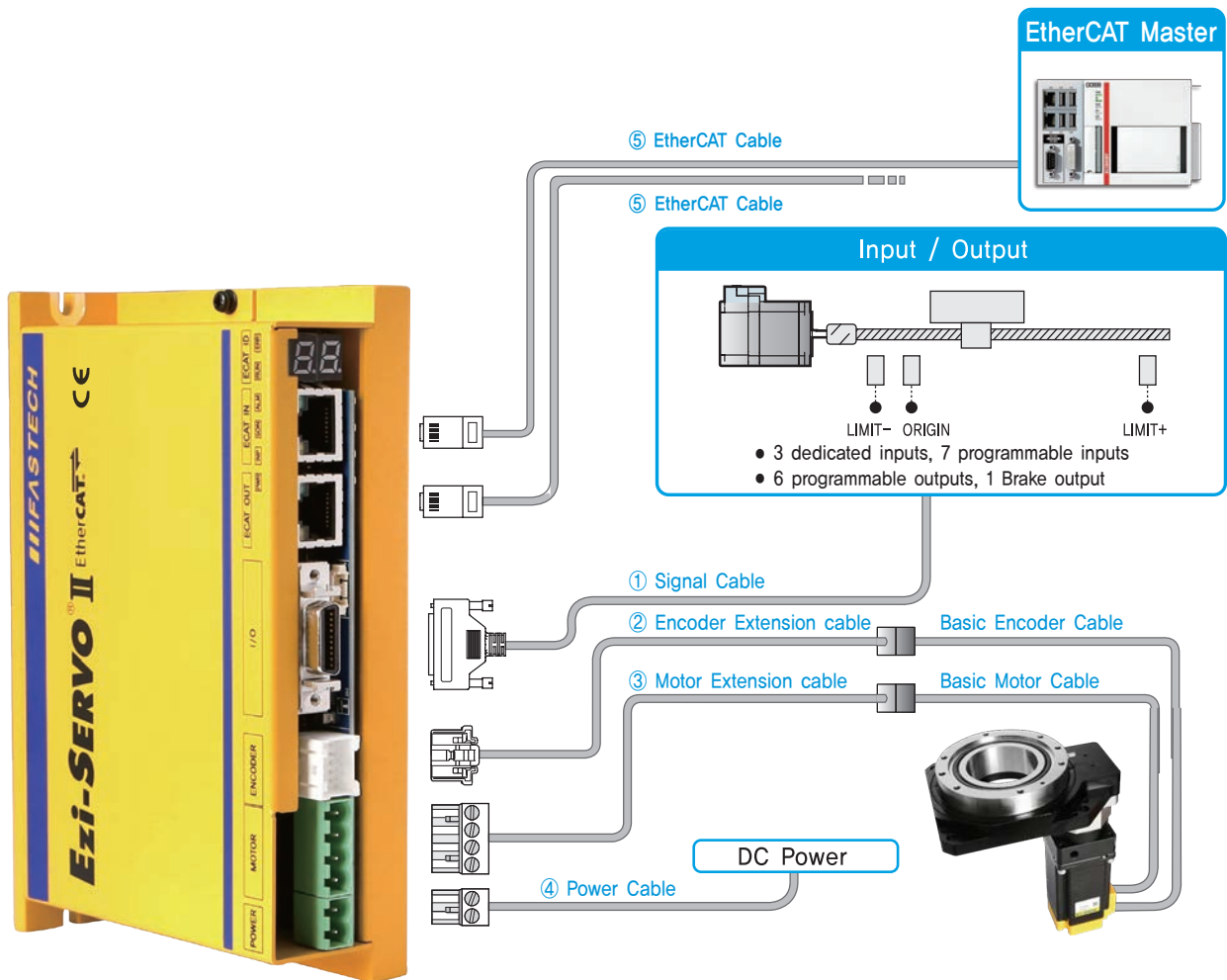

FASTECH Ezi-Robo HG

| Cable Type | Max. Length | Remarks |
|---------------------------|---------------------|--------------------------------------|
| ① Signal Cable | 20m | Options (Sold separately) |
| ② Encoder Extension Cable | 20m | |
| ③ Motor Extension Cable | 20m | |
| ④ Power Cable | 2m | |
| ⑤ EtherCAT Cable | 100m | Basic cables are attached to motors. |
| Basic Encoder Cable | 0,3m (Basic length) | |
| Basic Motor Cable | 0,3m (Basic length) | |

- Ezi-SERVO II EtherCAT is stepping motor control system using EtherCAT, high speed ethernet (100Mbps Full-Duplex) based fieldbus, Ezi-SERVO II EtherCAT is EtherCAT slave module which supports CAN application layer over EtherCAT (CoE). It employs CiA 402 Drive Profile and supports Profile Position Mode, Homing Mode, Cyclic Synchronous Position Mode.
- Please refer to Ezi-SERVO II EtherCAT catalog for more detailed information about Ezi-SERVO II EtherCAT drive.

● System Configuration [EtherCAT Mini Type (Ezi-SERVO II EtherCAT MINI)]

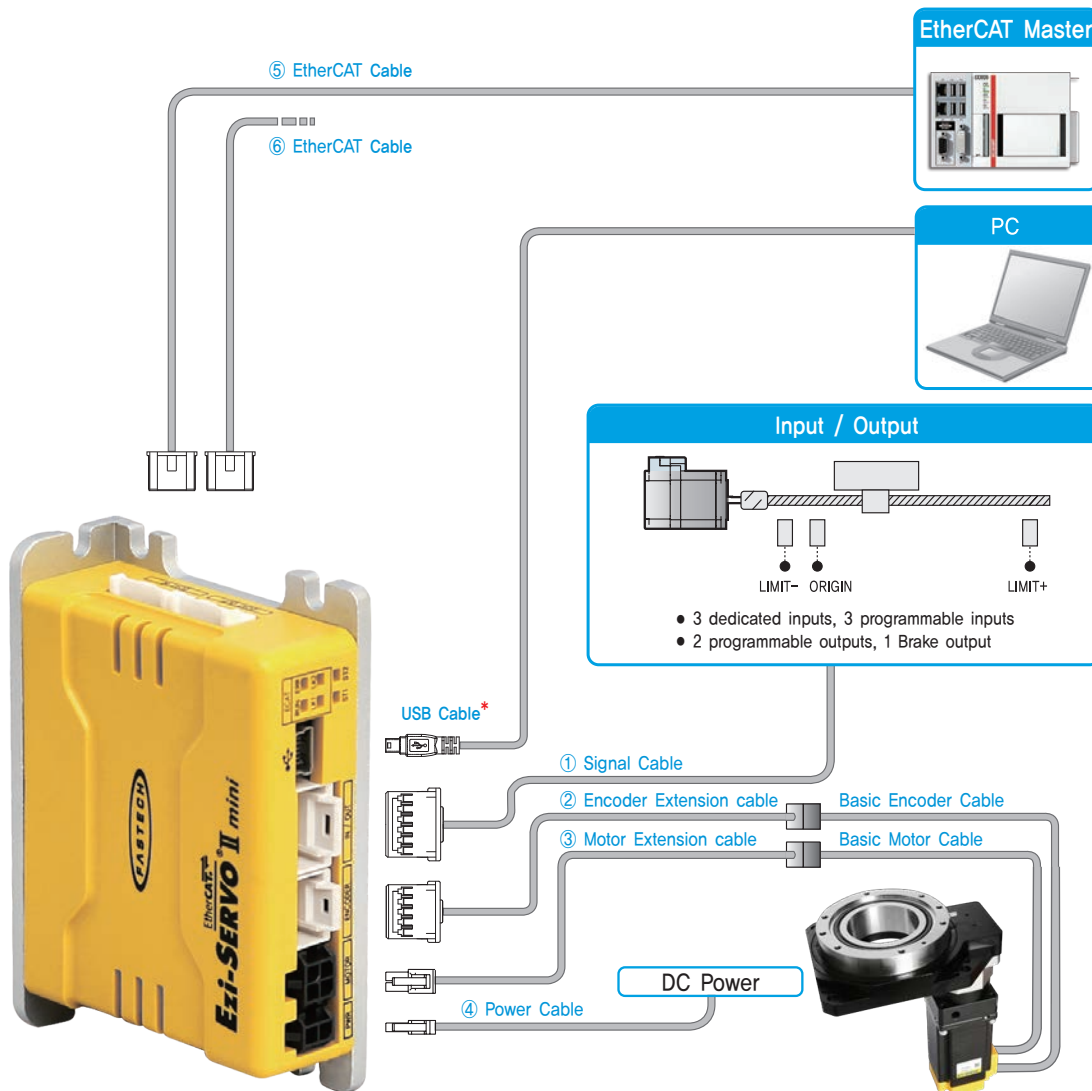

| Cable Type | Max. Length | Remarks |
|---------------------------|---------------------|-------------------------------------------------------------------------------------------------------------|
| ① Signal Cable | 20m | Options (Sold separately) |
| ② Encoder Extension Cable | 20m | |
| ③ Motor Extension Cable | 20m | |
| ④ Power Cable | 2m | |
| ⑤/⑥ EtherCAT Cable | 100m | Basic cables are attached to motors. |
| Basic Encoder Cable | 0,3m (Basic length) | |
| Basic Motor Cable | 0,3m (Basic length) | |
| USB Cable | 5m | * USB cables are not provided by FASTECH. We recommend using a standard USB cable (USB 2,0 Mini Type B). |

● Ezi-SERVO II EtherCAT MINI is stepping motor control system using EtherCAT, high speed ethernet (100Mbps Full-Duplex) based fieldbus. Ezi-SERVO II EtherCAT MINI is EtherCAT slave module which supports CAN application layer over EtherCAT (CoE). It employs CiA 402 Drive Profile and supports Profile Position Mode, Homing Mode, Cyclic Synchronous Position Mode.

● Please refer to Ezi-SERVO II EtherCAT MINI catalog for more detailed information about Ezi-SERVO II EtherCAT MINI drive.

● System Configuration [EtherCAT 4X (Ezi-SERVO|| EtherCAT 4X)]

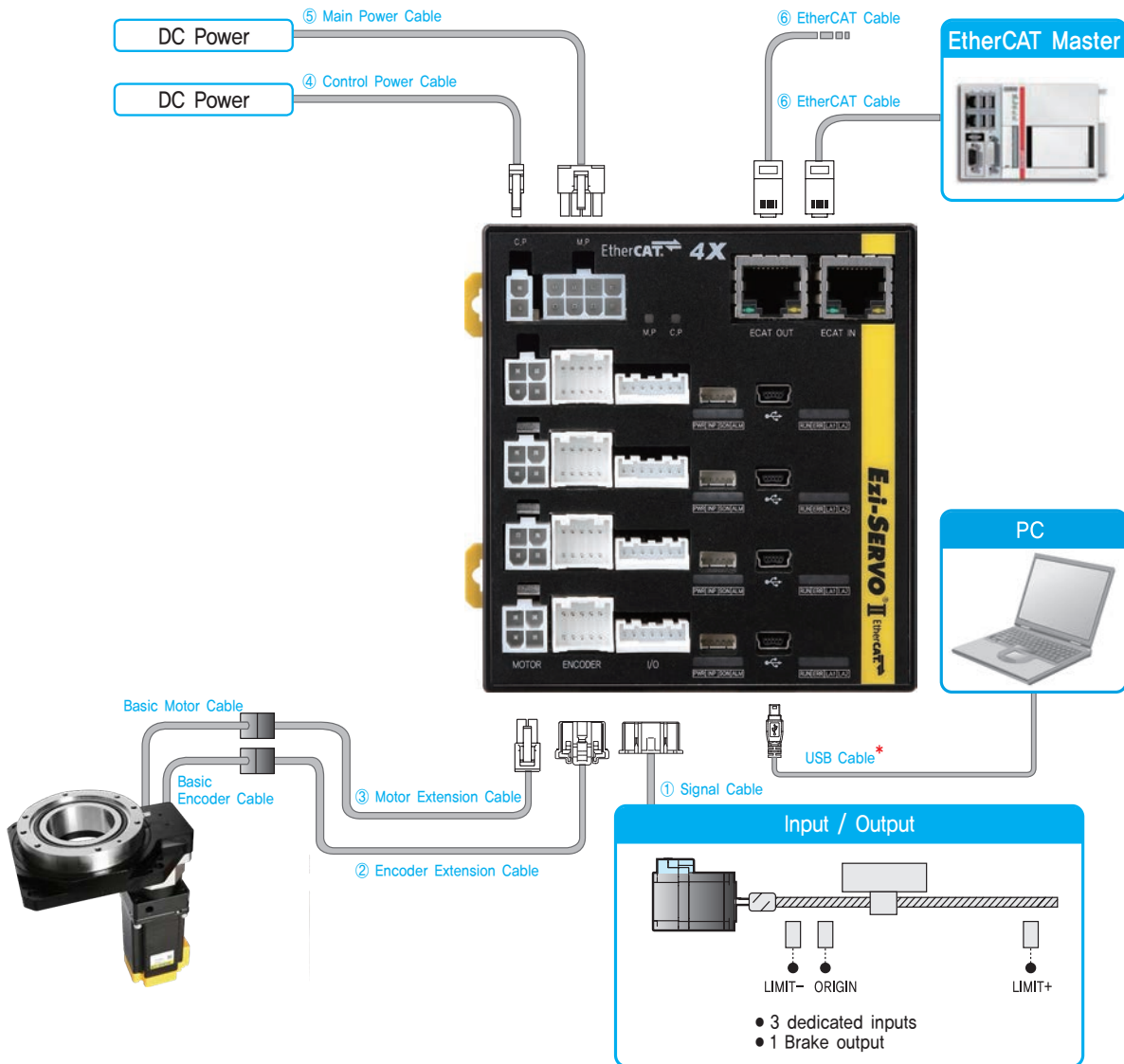

FASTECH Ezi-Robo HG

| Cable Type | Max. Length | Remarks |
|-------------------------|---------------------|-------------------------------------------------------------------------------------------------------------|
| ① Signal Cable | 20m | Options (Sold separately) |
| ② Encoder Cable | 20m | |
| ③ Motor Extension Cable | 20m | |
| ④ Control Power Cable | 2m | |
| ⑤ Main Power Cable | 2m | |
| ⑥ EtherCAT Cable | 100m | Basic cables are attached to motors. |
| Basic Encoder Cable | 0.3m (Basic length) | |
| Basic Motor Cable | 0.3m (Basic length) | |
| USB Cable | 5m | * USB cables are not provided by FASTECH. We recommend using a standard USB cable (USB 2.0 Mini Type B). |

- Ezi-SERVO II EtherCAT 4X is stepping motor control system using EtherCAT, high speed ethernet (100Mbps Full-Duplex) based fieldbus. Ezi-SERVO II EtherCAT 4X is EtherCAT slave module which supports CAN application layer over EtherCAT (CoE). It employs CiA 402 Drive Profile and supports Profile Position Mode, Homing Mode, Cyclic Synchronous Position Mode.
- Please refer to Ezi-SERVO II EtherCAT 4X catalog for more detailed information about Ezi-SERVO II EtherCAT 4X drive.

● System Configuration [Ethernet (Ezi-SERVO II Plus-E)]

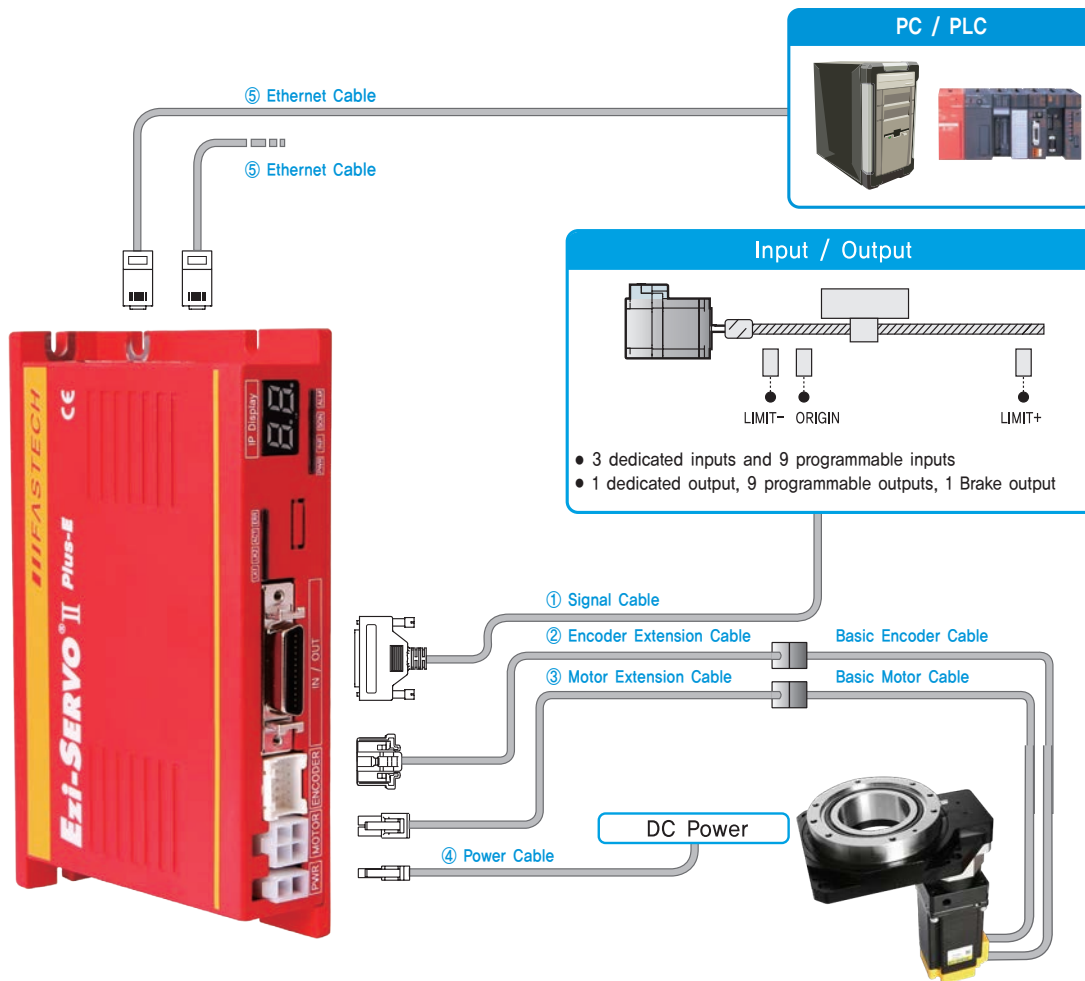

| Cable Type | Max. Length | Remarks |
|---------------------------|---------------------|--------------------------------------|
| ① Signal Cable | 20m | Options (Sold separately) |
| ② Encoder Extension Cable | 20m | |
| ③ Motor Extension Cable | 20m | |
| ④ Power Cable | 2m | |
| ⑤ Ethernet Cable | 100m | Basic cables are attached to motors. |
| Basic Encoder Cable | 0,3m (Basic length) | |
| Basic Motor Cable | 0,3m (Basic length) | |

● Ezi-SERVO II Plus-E is a stepping motor control system that can drive up to 254 axis through Ethernet. It has a built-in Ethernet switch, so the system can be built in a daisy chain method. All motions can be controlled by Ethernet communication, and the conditions related to motions are stored in ROM as parameters. In addition, Ezi-SERVO II Plus-E provides a motion library(API) for programming in Windows 7/8/10.

● Please refer to Ezi-SERVO II Plus-E catalog for more detailed information about Ezi-SERVO II Plus-E drive.

● System Configuration [Ethernet (Ezi-SERVO II Plus-E 86mm)]

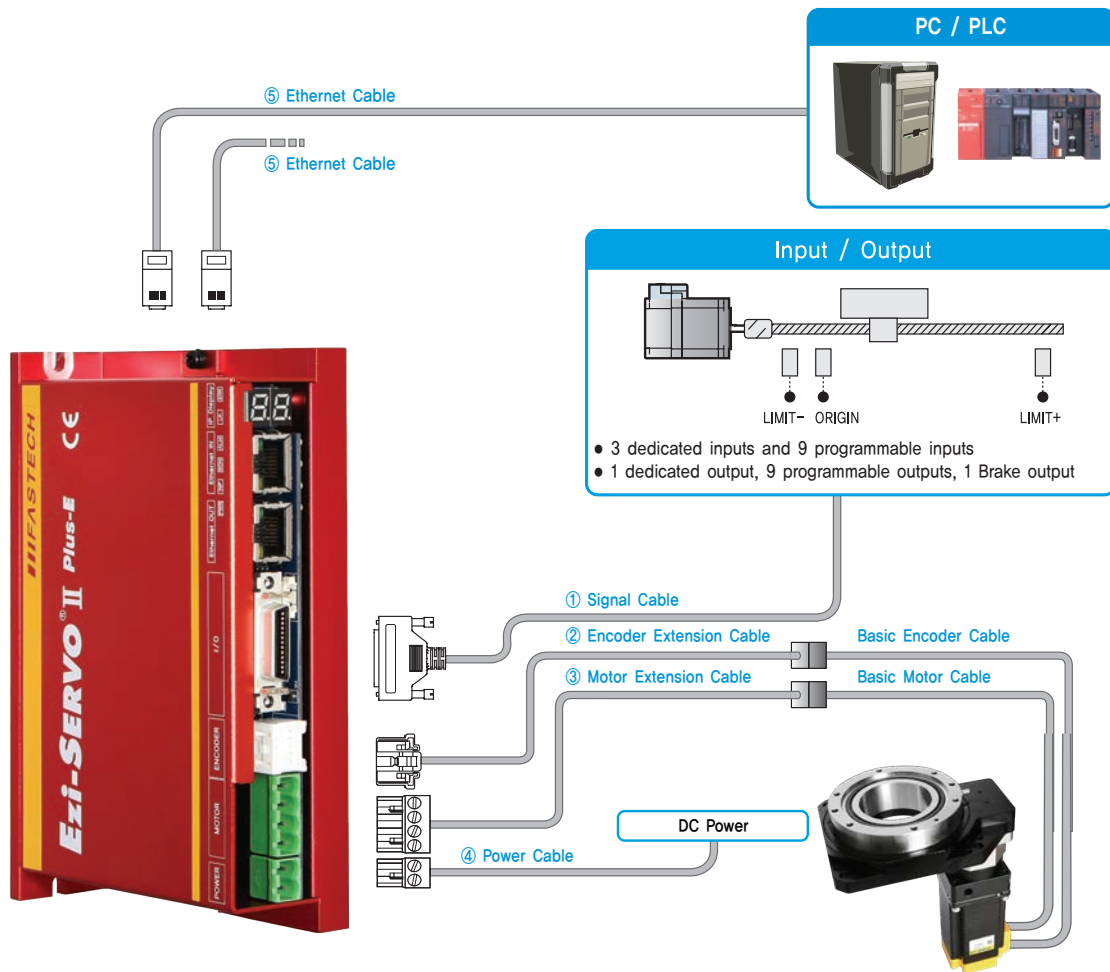

| Cable Type | Max. Length | Remarks |
|---------------------------|---------------------|--------------------------------------|
| ① Signal Cable | 20m | Options (Sold separately) |
| ② Encoder Extension Cable | 20m | |
| ③ Motor Extension Cable | 20m | |
| ④ Power Cable | 2m | |
| ⑤ Ethernet Cable | 100m | Basic cables are attached to motors. |
| Basic Encoder Cable | 0,3m (Basic length) | |
| Basic Motor Cable | 0,3m (Basic length) | |

● Ezi-SERVO II Plus-E is a stepping motor control system that can drive up to 254 axis through Ethernet. It has a built-in Ethernet switch, so the system can be built in a daisy chain method. All motions can be controlled by Ethernet communication, and the conditions related to motions are stored in ROM as parameters. In addition, Ezi-SERVO II Plus-E provides a motion library(API) for programming in Windows 7/8/10.

● Please refer to Ezi-SERVO II Plus-E catalog for more detailed information about Ezi-SERVO II Plus-E drive.

● System Configuration [Ethernet Mini Type (Ezi-SERVO II Plus-E MINI)]

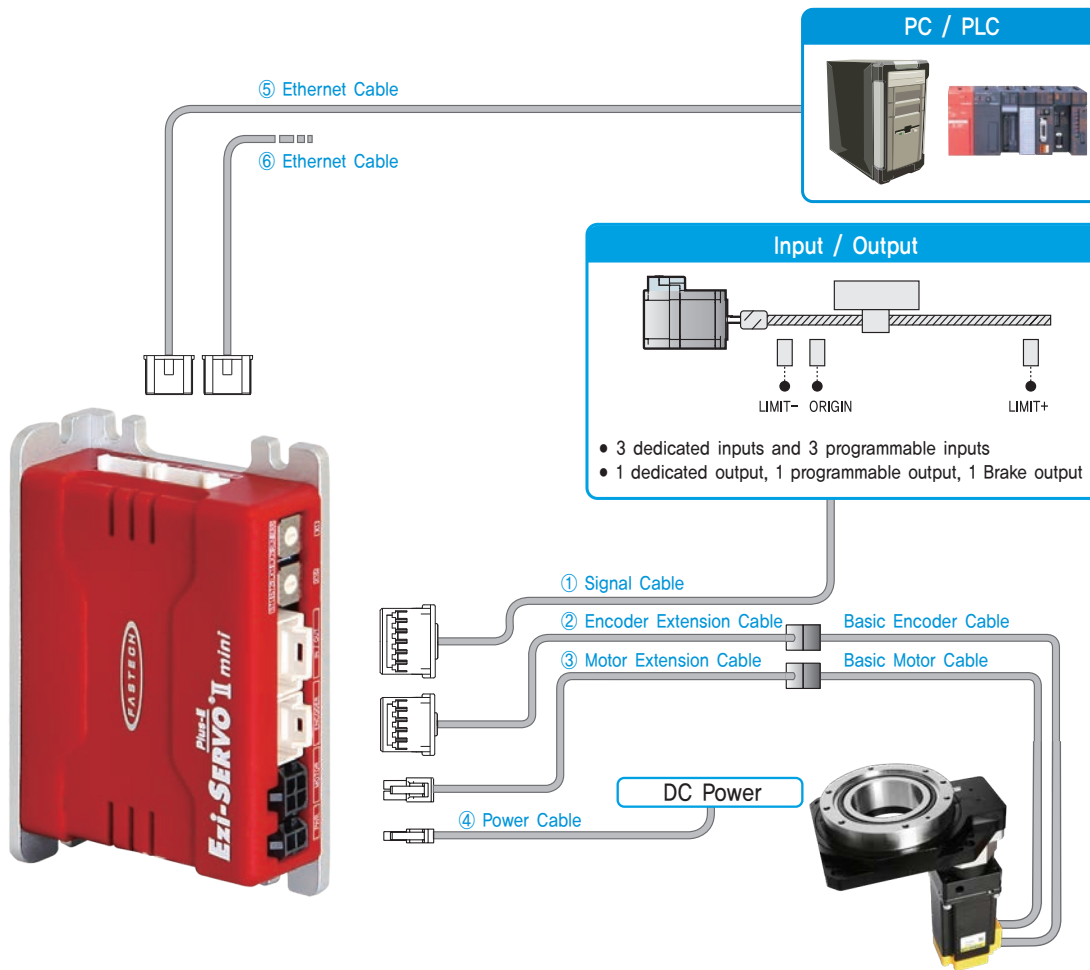

| Cable Type | Max. Length | Remarks |
|---------------------------|---------------------|--------------------------------------|
| ① Signal Cable | 20m | Options (Sold separately) |
| ② Encoder Extension Cable | 20m | |
| ③ Motor Extension Cable | 20m | |
| ④ Power Cable | 2m | |
| ⑤/⑥ Ethernet Cable | 100m | Basic cables are attached to motors. |
| Basic Encoder Cable | 0,3m (Basic length) | |
| Basic Motor Cable | 0,3m (Basic length) | |

● Ezi-SERVO II Plus-E MINI is a stepping motor control system that can drive up to 254 axis through Ethernet. It has a built-in Ethernet switch, so the system can be built in a daisy chain method. All motions can be controlled by Ethernet communication, and the conditions related to motions are stored in ROM as parameters. In addition, Ezi-SERVO II Plus-E MINI provides a motion library(API) for programming in Windows 7/8/10.

● Please refer to Ezi-SERVO II Plus-E MINI catalog for more detailed information about Ezi-SERVO II Plus-E MINI drive.

● System Configuration [CC-Link (Ezi-SERVO II CC-Link)]

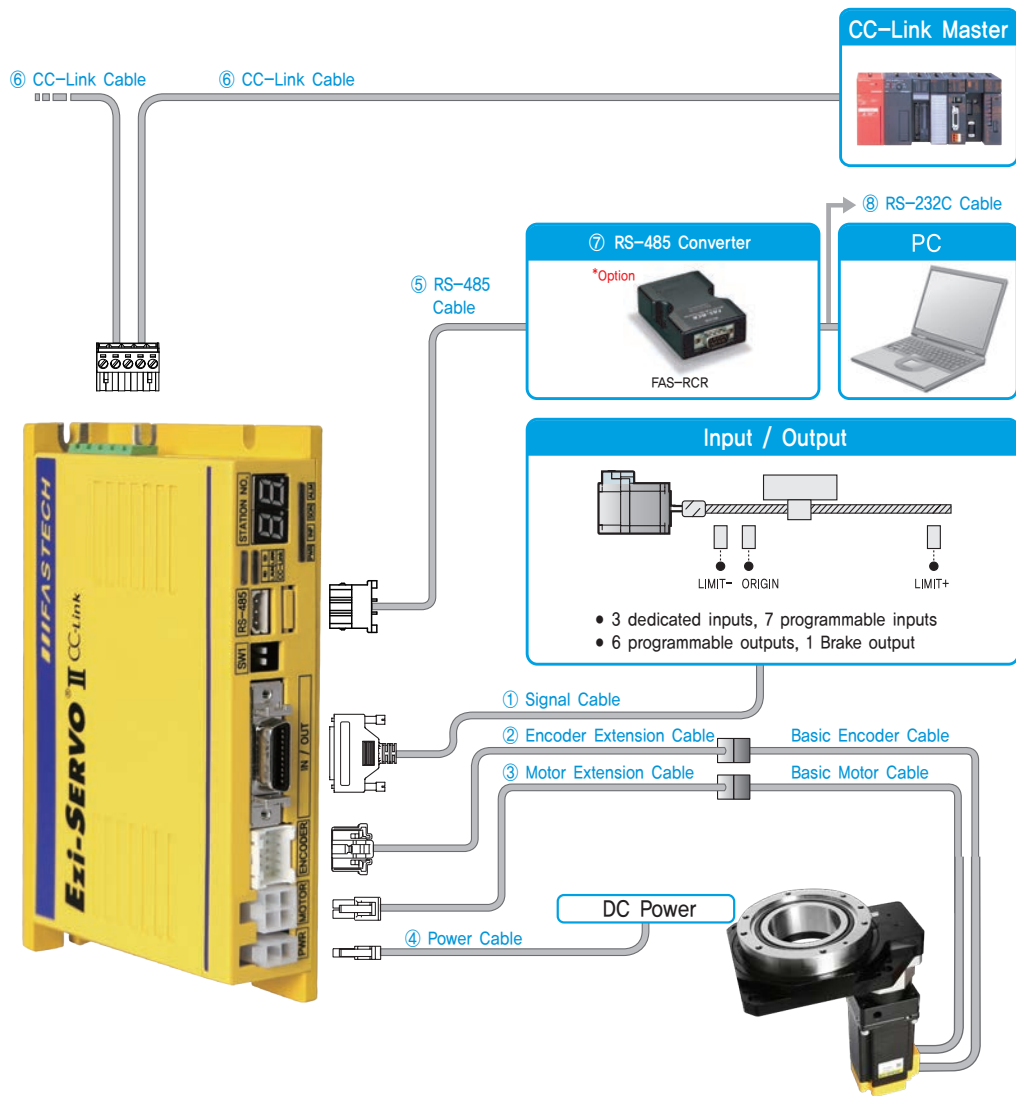

FASTECH Ezi-Robo HG

| Cable Type | Max. Length | Remarks |
|---------------------------|---------------------|--------------------------------------|
| ① Signal Cable | 20m | Options (Sold separately) |
| ② Encoder Extension Cable | 20m | |
| ③ Motor Extension Cable | 20m | |
| ④ Power Cable | 2m | |
| ⑤ RS-485 Cable | 2m | Basic cables are attached to motors. |
| ⑥ CC-Link Cable | 100m | |
| Basic Encoder Cable | 0.3m (Basic length) | |
| Basic Motor Cable | 0.3m (Basic length) | |

- Ezi-SERVO II CC-Link is a remote device module that supports high speed Fieldbus(Max, 10Mbps) network. It occupies 1 to 3 station in CC-Link, enabling multi-function control, and processes motion and monitoring functions with device commands.
- Please refer to Ezi-SERVO II CC-Link catalog for more detailed information about Ezi-SERVO II CC-Link drive.

● System Configuration [CC-Link (Ezi-SERVO II CC-Link 86mm)]

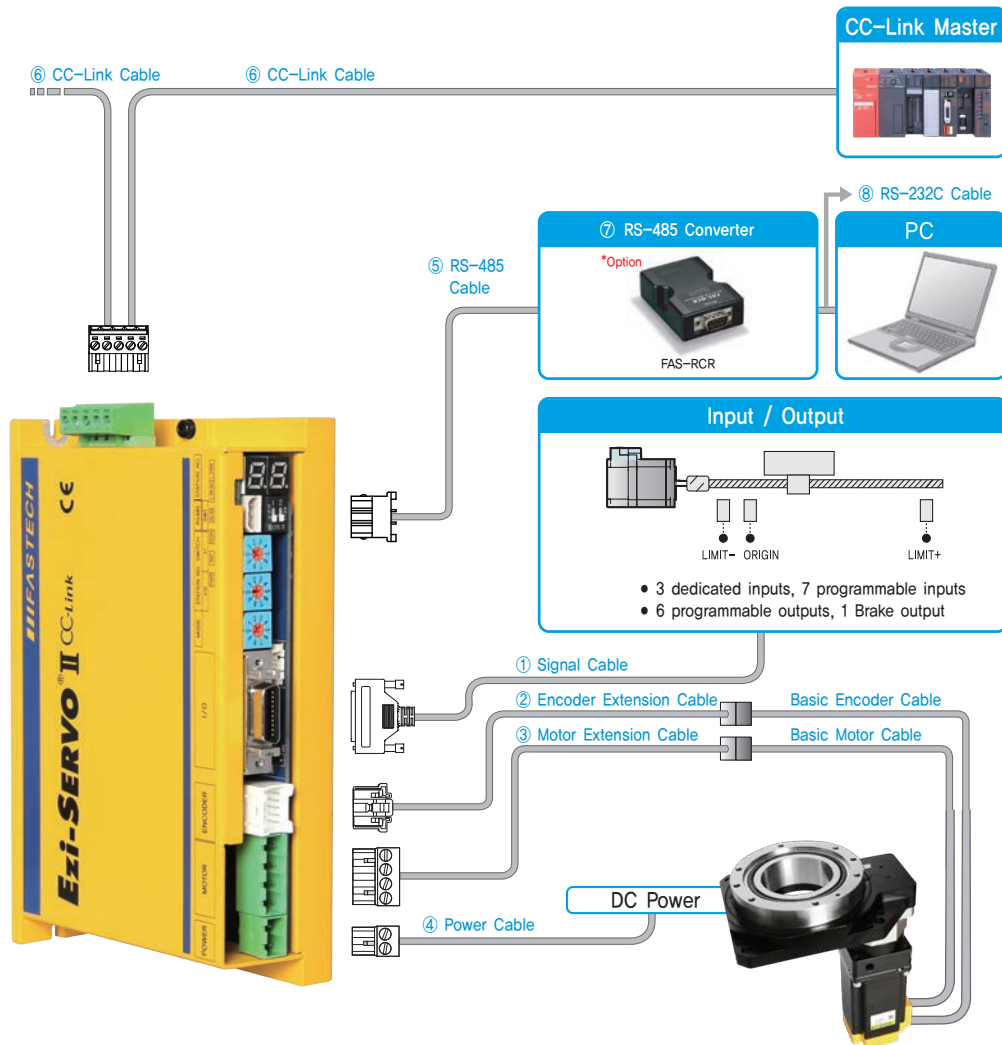

| Cable Type | Max. Length | Remarks |
|---------------------------|---------------------|--------------------------------------|
| ① Signal Cable | 20m | Options (Sold separately) |
| ② Encoder Extension Cable | 20m | |
| ③ Motor Extension Cable | 20m | |
| ④ Power Cable | 2m | |
| ⑤ RS-485 Cable | 2m | |
| ⑥ CC-Link Cable | 100m | Basic cables are attached to motors. |
| Basic Encoder Cable | 0,3m (Basic length) | |
| Basic Motor Cable | 0,3m (Basic length) | |

- Ezi-SERVO II CC-Link is a remote device module that supports high speed Fieldbus(Max. 10Mbps) network. It occupies 1 to 3 station in CC-Link, enabling multi-function control, and processes motion and monitoring functions with device commands.
- Please refer to Ezi-SERVO II CC-Link catalog for more detailed information about Ezi-SERVO II CC-Link drive.

● System Configuration [Pulse Input Type (Ezi-SERVO ST)]

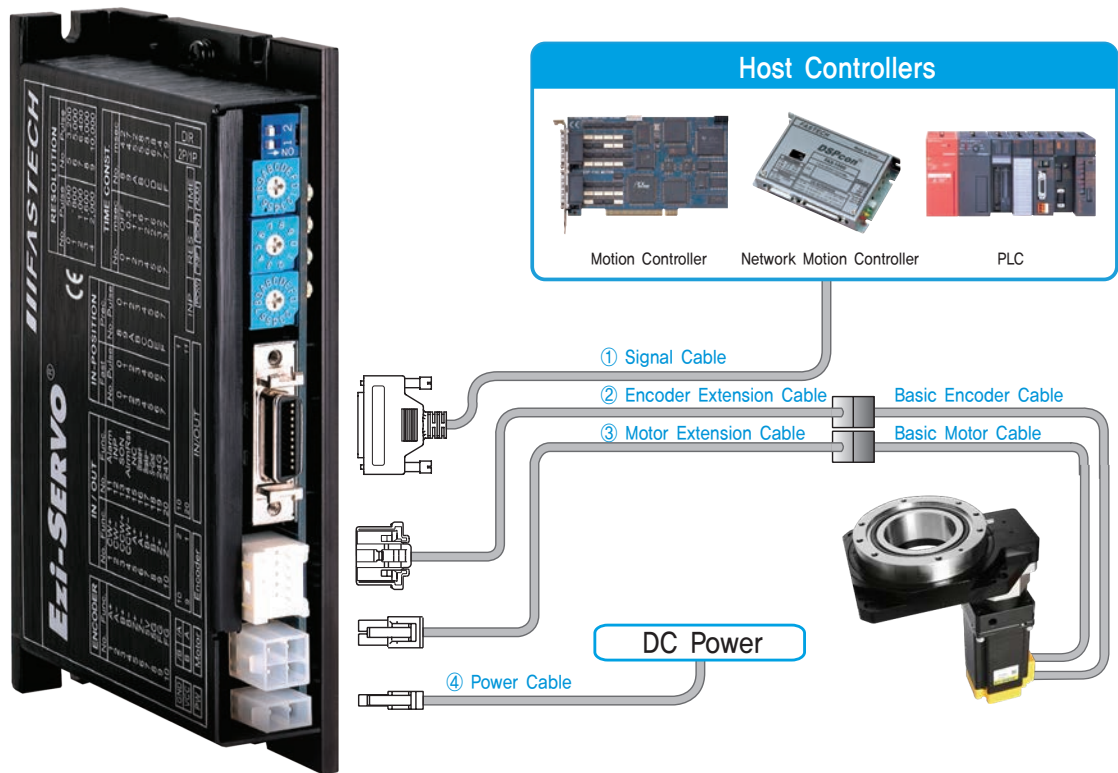

| Cable Type | Max. Length | Remarks |
|---------------------------|---------------------|--------------------------------------|
| ① Signal Cable | 20m | Options (Sold separately) |
| ② Encoder Extension Cable | 20m | |
| ③ Motor Extension Cable | 20m | |
| ④ Power Cable | 2m | |
| Basic Encoder Cable | 0.3m (Basic length) | Basic cables are attached to motors. |
| Basic Motor Cable | 0.3m (Basic length) | |

- Ezi-SERVO ST is a pulse input type drive.
- Please refer to Ezi-SERVO ST catalog for more detailed information about Ezi-SERVO ST drive.

● System Configuration [Pulse Input Type (Ezi-SERVO ST 86mm)]

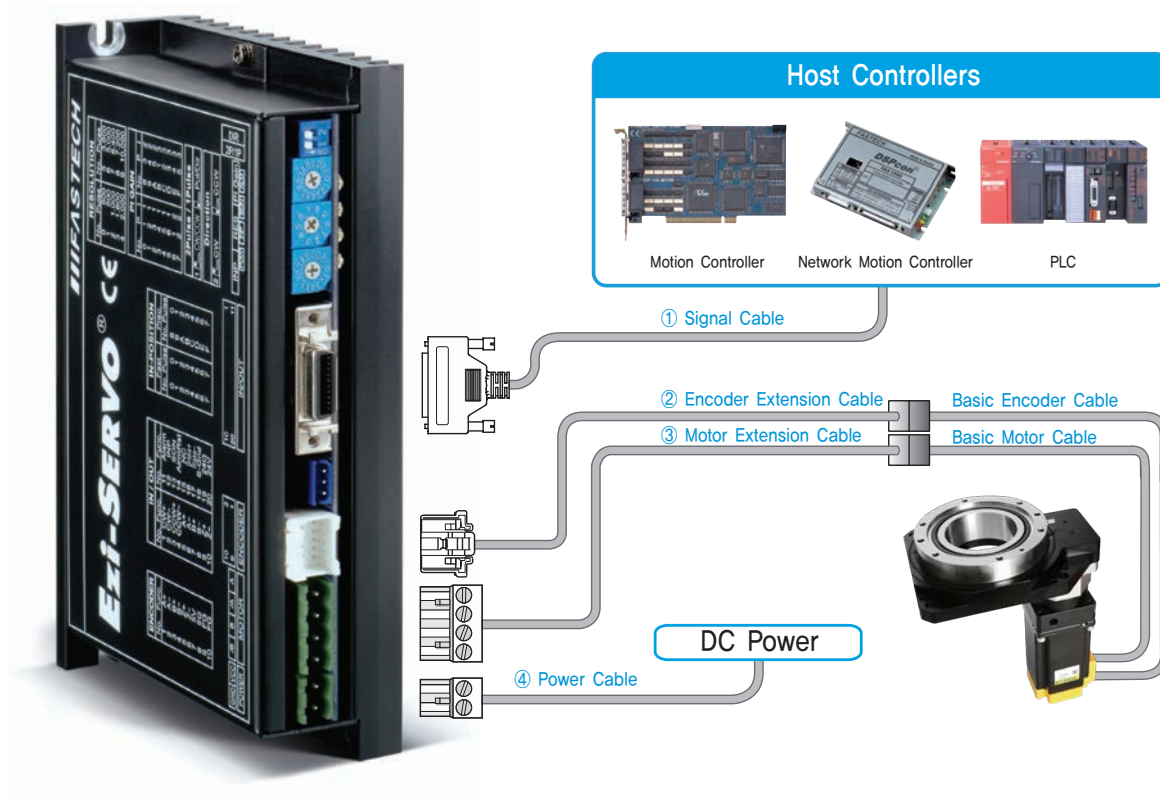

| Cable Type | Max. Length | Remarks |
|---------------------------|---------------------|--------------------------------------|
| ① Signal Cable | 20m | Options (Sold separately) |
| ② Encoder Extension Cable | 20m | |
| ③ Motor Extension Cable | 20m | |
| ④ Power Cable | 2m | Basic cables are attached to motors. |
| Basic Encoder Cable | 0,3m (Basic length) | |
| Basic Motor Cable | 0,3m (Basic length) | |

- Ezi-SERVO ST is a pulse input type drive.
- Please refer to Ezi-SERVO ST catalog for more detailed information about Ezi-SERVO ST drive.

● Home Sensor Installation Dimensions [RB-HG60]

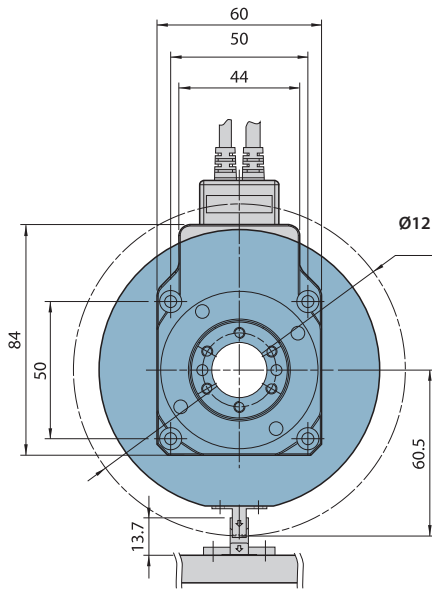

Ø121 (Rotating Diameter of Shielding Plate)

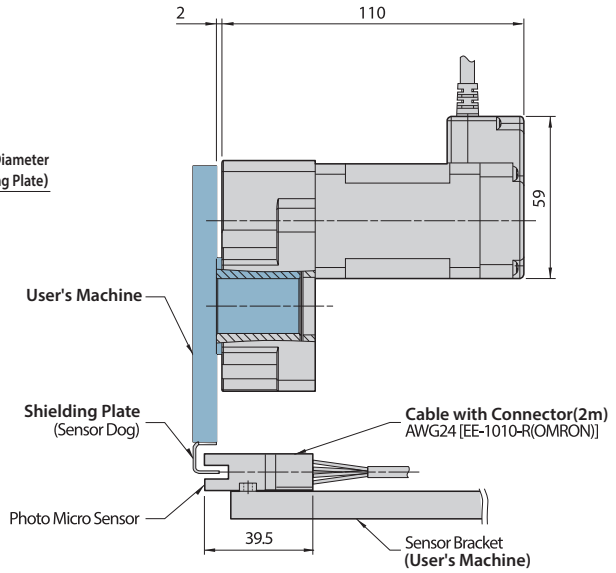

Shielding Plate Dimensions

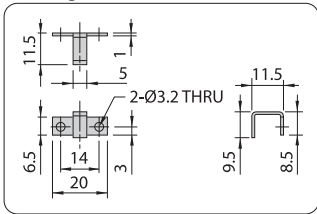

● Home Sensor Installation Dimensions [RB-HG100]

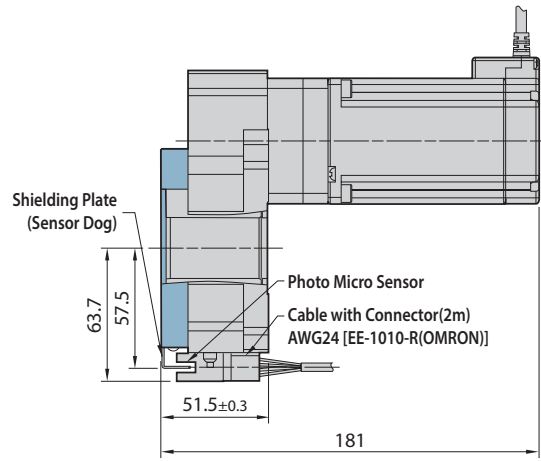
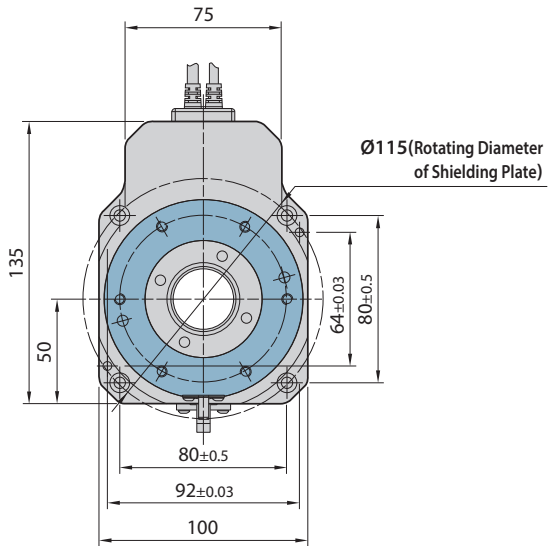

Shielding Plate Dimensions

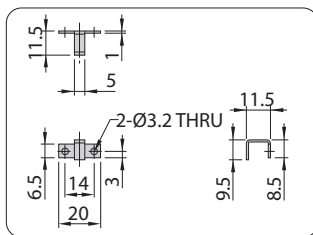

● Home Sensor Installation Dimensions [RB-HG130S]

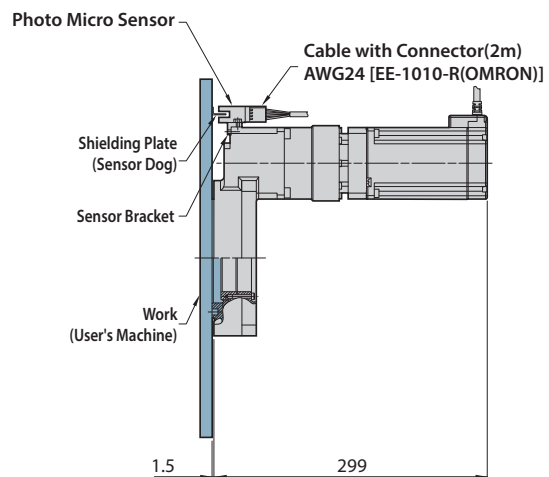
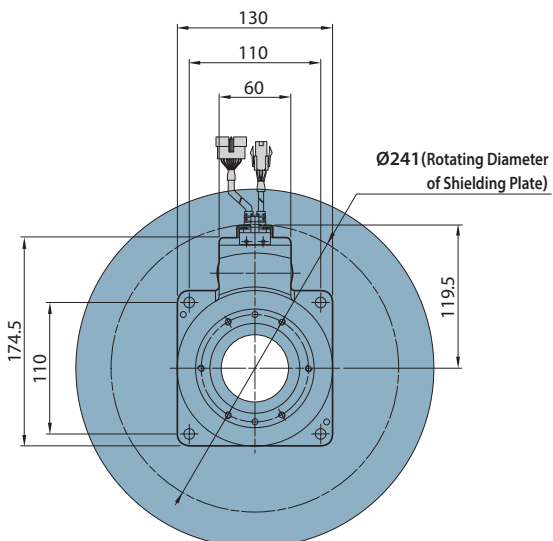

● Home Sensor Installation Dimensions [RB-HG170S-60L]

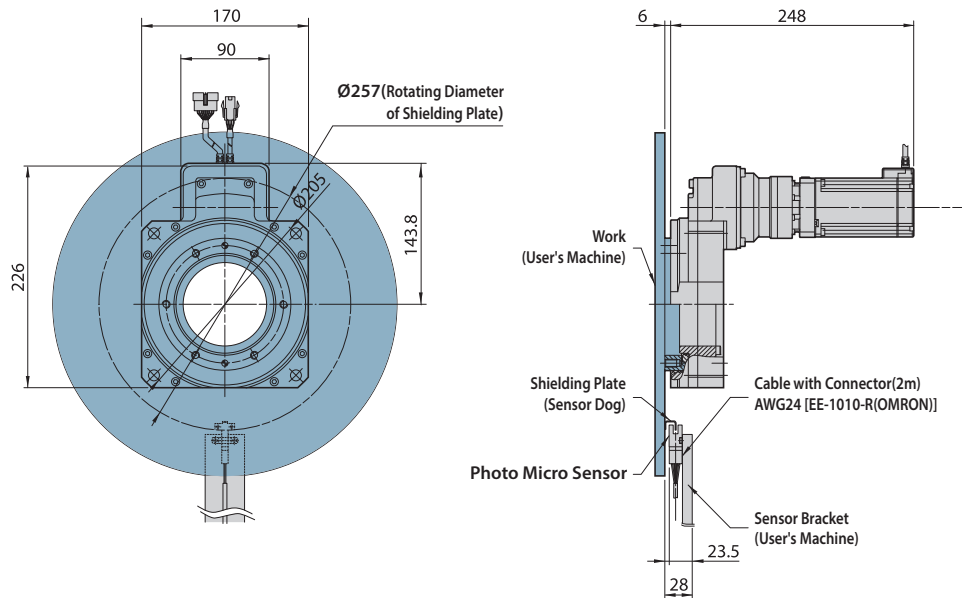

● Home Sensor Installation Dimensions [RB-HG170S-86L]

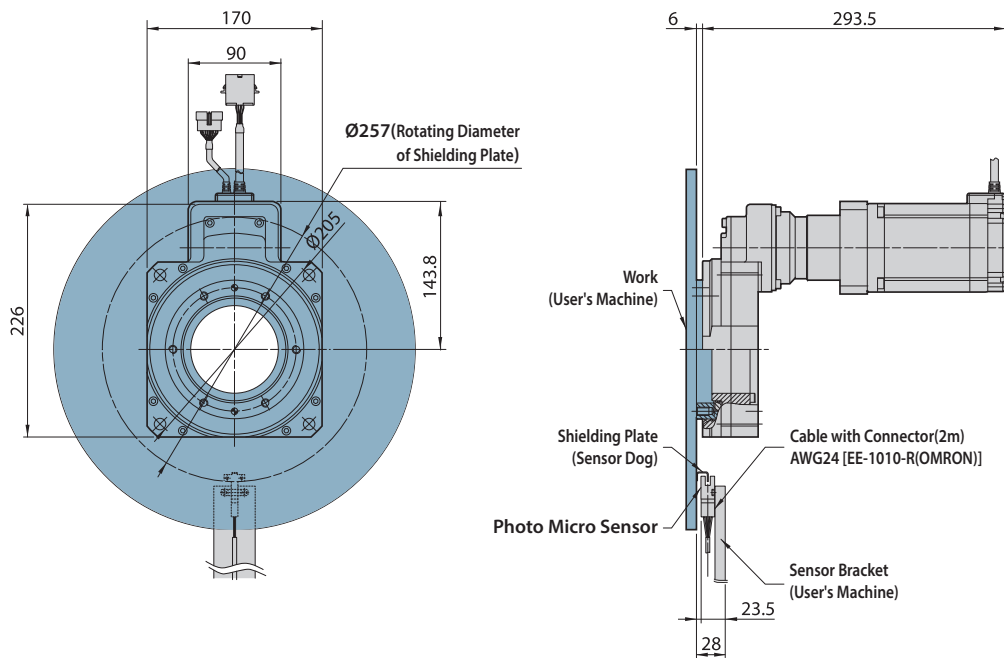

MEMO



Fast, Accurate, Smooth Motion

FASTECH Co., Ltd.

Rm#1202, 401-dong, Bucheon Techno-Park,
655, Pyeongcheon-ro, Bucheon-si Gyeonggi-do,
Republic of Korea (Postal Code: 14502)
TEL : +82-32-234-6317 FAX : +82-32-234-6302
E-mail : sales@fastech-motions.com
Homepage : www.fastech-motions.com