

**DYNAMIK DURCH
WIDERSTAND**

***DYNAMICS
THROUGH RESISTANCE***

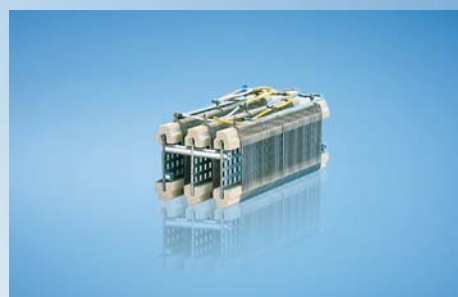

FRIZLEN
LEISTUNGSWIDERSTÄNDE
POWER RESISTORS

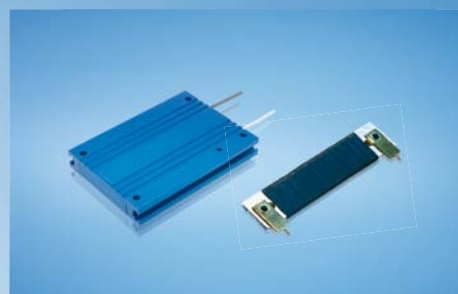

DYNAMIK DURCH WIDERSTAND

Wir über uns

DYNAMICS THROUGH RESISTANCE

About us

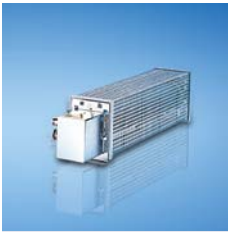

DIE KLASSIKER

Drahtgewickelte Rohrfestwiderstände
10 bis 6000 Watt

THE ORIGINAL ONES

Wirewound tubular fixed resistors
10 up to 6000 Watt



DIE FLEXIBLEN

**Zementierte
Drahtdrehwiderstände**
16 bis 1500 Watt

THE FLEXIBLE ONES

**Cement coated wirewound
variable resistors**
16 up to 1500 Watt

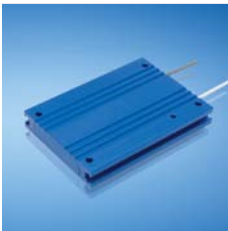

DIE INNOVATIVEN

**Drahtgewickelte Flachwiderstände,
auch gekapselt und in wassergekühlter
Ausführung**
5 bis 40000 Watt

THE INNOVATIVE ONES

**Wirewound flat resistors,
also enclosed and
watercooled**
5 up to 40000 Watt



DIE BELASTBAREN

Last- und Prüfwiderstände
0,01 bis 250 Kilowatt

THE LOADABLE ONES

Load- and test resistors
0.01 up to 250 Kilowatt



DIE MODULAREN

**Drahtgewickelte
Lamellenfestwiderstände**
0,15 bis 30 Kilowatt

THE MODULAR ONES

**Wirewound lamina type
fixed resistors**
0,15 up to 30 Kilowatt



DIE ROBUSTEN

Stahlgitterfestwiderstände
0,5 bis 250 Kilowatt

THE ROBUST ONES

Steel-grid fixed resistors
0,5 up to 250 Kilowatt



FRIZLEN SONDERGERÄTE

DC-POWERSWITCH
Kundenspezifische Widerstandsgeräte

FRIZLEN SPECIAL DEVICES

DC-POWERSWITCH
Customised resistor units

Das richtige Produkt für Ihre Anwendung

Suitable products for your application

Anwendungen	Application	Typleistung [kW]		Produktgruppe					
		min.	max.	T 100	T 200	T 300	T 400	T 500	T 600
Bremswiderstände für Frequenzumrichter- und Gleichstromantriebe	<i>Braking resistors for frequency converters and DC drives</i>	0,01	40,0			X		X	
		0,01	6,0	X				X	X
		6,0	30,0					X	X
		30,0	250						X
Belastungswiderstände für Spannungsquellen, Batterien, USV-Geräte, Generatoren und Netzgeräte	<i>Load resistors for supply units, power packs, batteries, UPS units and generators</i>	0,01	250				X		
Stufenlose Drehzahlverstellung von kleinen Gleich- und Wechselstrommotoren	<i>Stepless variable speed adjustment for small AC and DC motors</i>	0,01	1,5		X		X		
Feldsteller für Generatoren, Widerstände zur Strom- und Spannungsbegrenzung	<i>Field rheostats for generators, resistors for current and voltage limitation</i>	0,01	3,8	X	X				
Motorische Potentiometer als fernbetätigte Sollwertgeber	<i>Motorised potentiometers as nominal value setters</i>	0,01	1,5		X				
Widerstandsbaugruppen für Einbau in leistungselektronische Geräte	<i>Resistor modules fitting into electronic power devices</i>	0,01	0,75	X		X		X	
		0,3	2,0					X	
Anlass- und Stellwiderstände für Schleifringläufer- und Gleichstrommotoren	<i>Starting and regulating resistors for slip-ring rotor and DC motors</i>	0,15	30,0					X	
		0,5	250						X
Ständer-Vorschaltwiderstände für Kurzschlussläufermotoren	<i>Stator series resistors for squirrel-cage motors</i>	0,5	250						X
Strombegrenzungswiderstände zur Ladung und Entladung von Kondensatoren	<i>Resistors for current limitation e.g. for charging and discharging of capacitors</i>	0,01	1,0	X		X		X	
Experimentier- und Prüfwiderstände in Laboratorien, Schulen und Universitäten	<i>Resistors for experimenting and testing in laboratories, schools and universities</i>	0,01	50				X		
Widerstände zur Schutzbeschaltung, Filterwiderstände	<i>Protective resistors, filter resistors</i>	0,01	0,75	X		X		X	
		0,75	6,0	X				X	
		1,5	22,0						X



Wir über uns

Mit FRIZLEN Leistungswiderständen haben Sie elektrische Leistung voll im Griff.



Unser umfassendes Know-how zeigt sich im kompletten Spektrum vom Einzelstück bis zur Serie, für Leistungen von 5 Watt bis 250 Kilowatt.



Einsatz- und Anwendungsgebiete stellen die Anforderungen, die Lösungen entwickeln wir.

Ihrem Anforderungsprofil entsprechend berechnen und fertigen wir Widerstände und Widerstandskombinationen unter Berücksichtigung Ihrer Vorgaben. Natürlich beraten wir Sie gern und ermitteln auf Wunsch die Widerstandsdimensionierung mit Hilfe EDV-gestützter Berechnung und Simulation.

Hochwertige Standard- sowie Sonderlösungen von FRIZLEN sorgen für Dynamik im Verbund mit leistungselektronischen Geräten in Maschinen und Anlagen. Bewegung zu stoppen, konstant zu halten und exakte Abläufe zu ermöglichen – dabei unterstützen wir die elektrische Antriebstechnik und verbessern so die Dynamik Ihrer Antriebe.

About us

Keep your electric power under control with FRIZLEN power resistors.

Our extensive know-how is demonstrated in a complete spectrum from single item up to series production, for power values from 5 watts up to 250 kilowatts.

Different ranges of use and application set the requirements, we provide the solutions.

We design and produce resistors and resistor combinations exactly to meet your requirements. We are, of course, happy to advise you according to your specification. Upon request, we can determine resistor dimensioning using our computer-supported calculation and simulation system.

High-quality standard and special solutions from FRIZLEN ensure dynamics when you are dealing with high performance electrical equipment in machines and processes. We support electrically driven power engineering by stopping movement, keeping it constant and ensuring exact sequences, which improves the dynamics of your drive systems.

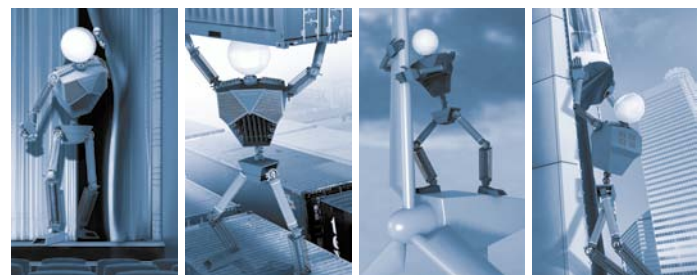



Drahtgewickelte Flachwiderstände

5 bis 40000 Watt

Drahtgewickelte Flachwiderstände als Einzelelemente, die einbaufähig sind und im Aluminiumgehäuse gekapselte Festwiderstände in verschiedenen Schutz- und Befestigungsarten.

- Anschluss an Litzen oder Lötpins, bei Einbau im Gehäuse auch an Klemmen
- Einzelwiderstände zu Baugruppen kombiniert für spezielle Einbaulösungen in Schutzart IP00
- Für waagerechte oder senkrechte Befestigung im Aluminiumgehäuse bis Schutzart IP67, auch in Mehrfachanordnung
- Für größere Leistungen in wassergekühlter Ausführung bei Schutzarten bis IP54

Wirewound flat resistors

5 up to 40000 Watt

Wirewound flat resistors as individual components in an open design that can be integrated into other units and composed to encapsulated flat resistor units in different degrees of protection and mounting types.

- With wires or soldering lugs, if enclosed connection to wires or terminals
- In degree of protection IP00 single elements can be combined to units for special requirements
- Up to degree of protection IP67 for horizontal and vertical mounting, also in multiple configuration
- Watercooled for higher continuous dissipation up to degree of protection IP54

Contents

This list comprises our wirewound flat resistors as individual components in an open design in type series GU and GZ, which can be integrated into other units and encapsulated flat resistor composed to different protection degrees and mounting solutions, further fixed resistors in multiple configurations and also water cooled.

<i>maximum power</i>	<i>characteristics, protection degree survey</i>	<i>units in maximum voltage</i>	<i>type series</i>	<i>page</i>
	technical details			T302E
				T304E
300 W	IP00, wires/lugs	848 VDC	GU./GZ.	T310E
960 W	IP40	800 VDC	GXTD.	T311E
165 W	IP40	800 VDC	GL./GM.	T312E
500 W	IP40	848 VDC	GL. /GM. /GN. /GP.	T313E
300 W	IP40	1100 VDC	GXAD./GXMD.	T314E
450 W	IP40	1100 VDC	GXAD./GXMD.	T315E
500 W	IP54	848 VDC	GH. /GV. /GA. /GB.	T316E
750 W	IP54 and IP67	848 VDC	GWAD. /GYAD.	T317E
500 W	IP54	848 VDC	GWAE.	T318E
1575 W	IP54 and IP67	848 VDC	KWAD. /KYAD.	T319E
1050 W	IP54	848 VDC	KWAE.	T320E
500 W	IP54	1100 VDC	GAMD./GBMD.	T321E
750 W	IP54 and IP67	1100 VDC	GWMD./GYMD.	T322E
1575 W	IP54 and IP67	1100 VDC	KWMD./KYMD.	T323E
500 W	IP54 and IP67	1400 VDC	GAND./GBND.	T324E
200 W	IP54	4200 VDC	GAPD./GBPD.	T325E
	type series in multiple configuration			
750 W	IP20, with terminals	848 VDC	GXHM./GXUM.	T340E
2520 W	IP54 and IP65	848 VDC	FDWZ./FYWZ.	T341E
4800 W	IP54 and IP65	848 VDC	FDAZ./FYAZ.	T342E
40000 W	IP54, water cooled	848 VDC	WPAZQ.	T343E
	Mounting kits for type series GX../GW../GY../KW../KY..			T350E – T353E
	Application example			T360E – T361E

Properties

- **short-circuit proof and self-extinguishing** (all type series except for GU / GZ)
⇒ therefore big operating safety
- **form- or force-locking fixation**
⇒ overload resistant at short time load
- **flat construction form, various lengths and widths**
⇒ can be integrated (nearly any length and width possible within max. dimensions), various possibilities for connection and mounting (type series GU / GZ)
- **enclosure from aluminium cast material, protection degree up to IP 67**
⇒ various types of protection and mounting (all type series except GU / GZ and GKTD)
- **heat sink mounting possible**
⇒ higher continuous dissipation, more specific heat dissipation (except GU / GZ)
- **UL-Recognition for the American and Canadian market (E212934)**
⇒ on request for the signed type series, pls. look on page T305



Applications

- braking resistors for frequency converters and DC drives
- load resistors for supply units, power packs, batteries, UPS units and generators
- current limiting resistors for loading and disloading of capacitors
- protective resistors







T 300 – survey – single resistors up to 1100 V DC

type series		GU + GZ	GXTD	GLAD + GMAD	GLAD GMAD GNAD GPAD	GXAD GXMD	GHAD GVAD GAAD GBAD	GWAD GYAD	GWAE	KWAD + KYAD	KWAE
	characteristics	page symbol	T310E	T311E	T312E	T313E	T314E + T315E	T316E	T317E	T318E	T319E
typical power from [W]		5	30	40	50	100	50	100	100	150	150
typical power up to [W]		300	960	165	500	450	500	750	500	1575	1050
degree of protection IP00	IP 00	X									
degree of protection IP40	IP 40		X	X	X	X					
degree of protection IP54	IP 54						X	X	X	X	X
degree of protection IP67	IP 67							X		X	
horizontal mounting			X	X	X	X	X	X	X	X	X
vertical mounting			X	X	X	X	X	X	X	X	X
can be integrated	E	X	X	X	X	X	X	X	X	X	X
temperature switch (optional)					X	X	X	X		X	
max. voltage 800 VDC	800V DC		X	X							
max. voltage 848 VDC	848V DC	X			X	X	X	X	X	X	X
max. voltage 1100 VDC	1100V DC					X					
max. voltage 1400 VDC	1400V DC										
max. voltage 4200 VDC	4200V DC										
with Recognition		X		X	X	X	X	X	X		X
with Recognition						X					

Rights for improvements and modifications of our products reserved.
 Modifications, errors and misprints justify no claim for damages.
 We refer to our terms of sales and delivery.

T 300 – survey – single resistors up to 4,2 kV DC and in multiple configurations

type series		GAMD + GBMD	GWMD + GYMD	KWMD + KYMD	GAND + GBND	GAPD + GBPD	GXHM + GXUM	FDWZ + FYWZ	FDAZ + FYAZ	WPAZQ
	characteristics	page symbol	T321E	T322E	T323E	T324E	T325E	T340E	T341E	T342E
typical power from [W]		110	100	150	110	200	100	225	160	10k
typical power up to [W]		500	750	1575	500	300	750	2520	4800	40k
degree of protection IP40	IP 40						X			
degree of protection IP54	IP 54	X	X	X	X	X		X	X	X
degree of protection IP65	IP 65							X	X	
degree of protection IP67	IP 67		X	X						
horizontal mounting		X	X	X	X	X	X	X	X	X
vertical mounting		X	X	X	X	X	X	X	X	X
can be integrated	E	X	X	X	X	X	X			X
temperature switch (optional)		X	X	X	X		X	X	X	X
max. voltage 800 VDC	800V DC									
max. voltage 848 VDC	848V DC						X	X	X	X
max. voltage 1100 VDC	1100V DC	X	X	X						
max. voltage 1400 VDC	1400V DC				X					
max. voltage 4200 VDC	4200V DC					X				
with  Recognition							X			
with  Recognition		X	X	X	X					

Rights for improvements and modifications of our products reserved.
 Modifications, errors and misprints justify no claim for damages.
 We refer to our terms of sales and delivery.



Technical details

Construction

Wirewound flat resistors consist of support straps and wiring. As standard version the support strap is made of mica. For resistor windings we use round wires consist of alloy CuNi 44 according to DIN 17471, 46460-1 and 46461 or of NiCr 3020 or CrAl 25 5 according to DIN 17470. We either wind an oxidized wire without gap (type GU) or fix them by non-slip strip cementing (type GZ), even if they lengthen a little when heated.

We surround the resistor installations of our encapsulated flat resistors with quartz sand. Then the wire will not slip and the heat transfer to the aluminium enclosure is reliable.

Resistance values/ Production tolerance/ Temperature dependency

The resistance values in the column "production range" refer to the standard production program, further values on request. The normal tolerance is $\pm 10\%$, restricted tolerance on request.

The resistance value slightly changes in dependency of the winding temperature. The temperature rise at the winding is $\Delta T \approx 300 \text{ K}$ when the rated power is operating continuously. Compared to the cooled off condition you have the following changes of resistance value: with wires made of CuNi 44 approx. $\pm 1\%$, of CrAl 25 5 approx. $+1\%$ and of NiCr 3020 approx. $+10\%$.

Degrees of protection

Correlation of type series and degrees of protection according to EN 60529 and/or DIN VDE 0470 part 1.

Type series	Degree of protection	First digit: Degree of protection against access & against solid foreign objects	Second digit: Degree of protection against water
GU GZ	IP 00	Non-protected – i.e. depending upon integration the user must provide a protection	Non-protected
GLAD GMAD GNAD GPAD GX..	IP 40	Protected against access to hazardous parts with a wire and against solid foreign objects of 1 mm \varnothing and greater.	Non-protected
GA.. GB.. GHAD GVAD GW.. KW..	IP 54	Protected against access to hazardous parts with a wire and against dust	Protected against splashing water. Water splashed against the enclosure from any direction shall have no harmful effects
GY.. KY..	IP 67	Protected against access to hazardous parts with a wire and dust-tight	Protected against the effects of temporary immersion in water. Ingress of water in quantities causing harmful effects shall not be possible when the enclosure is temporarily immersed in water under standardized conditions of pressure and time

IP
00

IP
40

IP
54

IP
67

CE

Devices with degrees of protection IP 20 or higher comply with the CE low voltage directive. Power resistors being passive electrical or electrical units are not affected by the specific EMC standards. They do not produce any interfering radiation nor are they affected.

Time constant

The average thermal time constant is 360 sec. under the condition of free mounting and cooling.

Wiring / Connections





All our encapsulated resistors in standard version have UL recognized FEP/PTFE-wires, that are partially also wired on terminals.
(Special wire insulations on request). If the wiring is accomplished by the customer, make sure that a heat resistant wire is used!

*Air- and creepage distances/
UL-Recognition*

All standard type series can be delivered in a version with UL-Recognition and are rated for the overvoltage category III, the air and creepage distances are rated according to IEC 664 (DIN VDE 0110 part 1). For protection degree IP40 the resistors are rated for pollution level 2, versions with protection degree IP 54 and higher are for pollution level 3.

These data are valid for all devices that are connected with mains voltage and derived voltages, as for example the intermediate circuit voltage of frequency converters.

The type of authorisation and the underlained three-phase main voltage are given in the survey.

Type of authorisation (E212934)	Authorisation up to	Grounded three-phase mains up to	Grounded and ungrounded three-phase mains up to	Testing voltage
 (CSA C22.2 No.14)	800 VDC	3 x 277/400 VAC	3 x 277 VAC	4,2 kV DC
 (CSA C22.2 No.14)	848 VDC	3 x 347/600 VAC	3 x 600 VAC	4,2 kV DC
	1100 VDC	3 x 400/690 VAC	3 x 690 VAC	4,2 kV DC
	1400 VDC	3 x 480/830 VAC	3 x 1000 VAC	4,2 kV DC

(Please ask for it or download it: www.frizlen.com).

Excess temperature protection



A version of the excess temperature monitoring particularly suited for long-term overloading is to equip with a temperature switch with two wires. It opens a signal contact when the set temperature is exceeded. The resistor is not switched off.

You can inform yourselves about function and restrictions by our data sheet „Tripping of monitoring device“.

Contact ratings

Contact ratings of the signal contact:

- 6,3 A / 230 VAC (cos phi = 0,6) resp. 2,0 A / 24 VDC

*Storage temperature/
Operation temperature/
Installation altitude*

Storage temperature: - 40° C to 80° C
 Operation temperature: - 30° C to 40° C. If the ambient temperature is higher than 40°C, you have to decrease the continuous dissipation by 4% per 10 K temperature rise!
 Installation altitude: 2000 m above sea level, you have to decrease the continuous dissipation for 10% per 1000 m altitude, maximum altitude 5000 m above sea level

*Typical power/
Continuous dissipation/
Ventilation/
Temperatures*

The given typical power values are valid for 100% duty cycle factor (DCF) (continuous dissipation) under the following conditions:

- temperature rise of 200 K at the surface of fixed resistors (degree of protection > IP00)
- temperature rise of 300 K at the surface of fixed resistor elements (degree of protection IP00).
- unhindered access of cooling air
- unhindered diverting of warmed up air (keep a minimum separation distance of approx. 200 mm to neighbouring components/walls and of approx. 300 mm to components above/ceiling)



Ventilation / temperatures

Since electrical energy is converted into heat, it is inevitable that the exhaust air will be heated up, as well as the section of enclosure at the surface. The highest temperature with typical power may be maximum 200°C above the ambient temperature. Since the cooling of the devices is accomplished by convection, the above mentioned aspects have absolutely to be considered.



In case of insufficient cooling or false mounting the resistor or the surrounding devices could be overheated or ruined.

Depending upon use it can be possible, to increase the continuous dissipation of the resistors, if higher temperatures are accepted. With increase e.g. of 130% of the typical power you will have a rise in temperature of 350K at the surface of the resistor. In other cases of applications the continuous dissipation must be reduced, for example with temperature sensitive devices in the surrounding. The dependence between temperature rise and actual continuous dissipation is shown in the diagram below.

Excess temperature in dependence of continuous dissipation

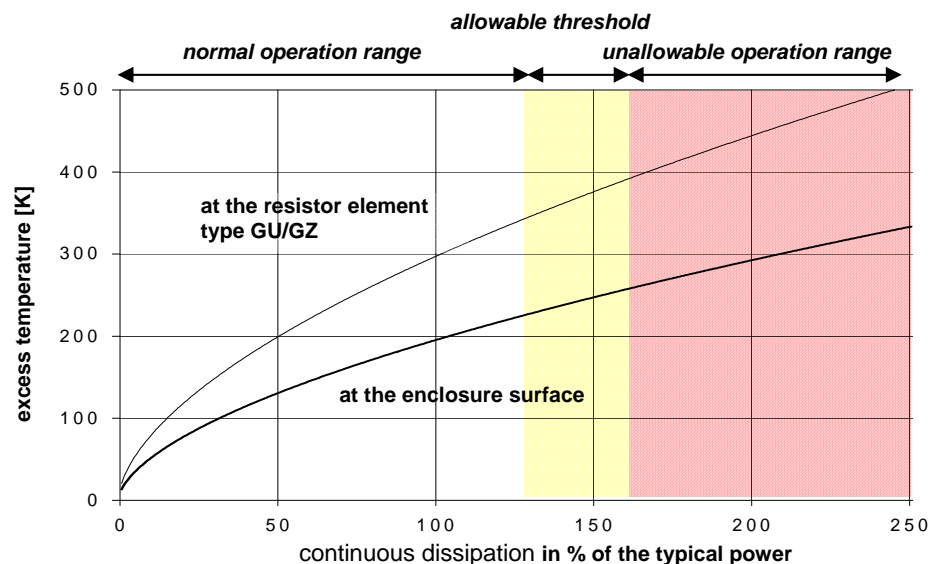

Normal operation range (up to 130%):

Recommended operation range for maximum product life and failure free operation

Allowable threshold (up to 160%):

Allowable operation range, danger of shorter product life and higher failure probability

Unallowable operation range (more than 160%):

Danger of excessive heat and destruction of resistor and neighbouring components

Short time dissipation/
Total cycle time/
Duty cycle factor(DCF)

In many applications resistors are not loaded in continuous but in short time operation. In the following you will find indications, how to calculate the allowable short time dissipation with the help of the duty cycle factor (DCF) and the overload factor (OLF). If the DCF factor is not known, it can be calculated as follows:

$$\text{Duty cycle factor(DCF)} = \frac{\text{Switch on time}(t_{on})}{\text{Total cycle time}}$$

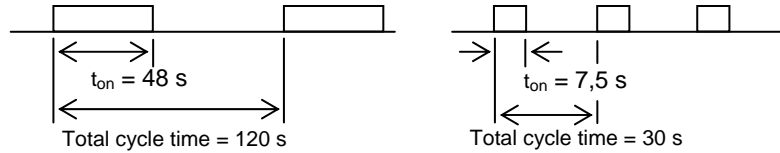

$$DCF_1 = \frac{48s}{120s} = 0,4 = 40\%$$

$$DCF_2 = \frac{7,5s}{30s} = 0,25 = 25\%$$

Warning: The total cycle time may be maximum 120 s - shorter total cycle times are possible. The total cycle times for motors are mostly higher than 120 s

Overload factor(OLF)

By comparison of the known DCF-factor with the following diagram or table you can work out the overload factor (OLF) and/or the continuous and the short time dissipation.

Overload factor (OLF) in dependence of duty cycle factor (DCF)
(Total cycle time 120s)

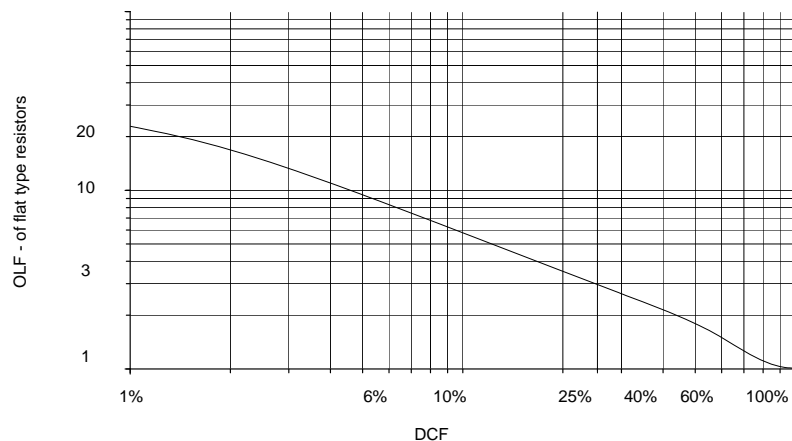

DCF	1%	3 %	6%	15%	25%	40%	60%	80%	100%
OLF	22	13	8,2	4,2	3,0	2,2	1,5	1,12	1,0

$$\text{Short time dissipation} = \text{Continuous dissipation} \times \text{OLF}$$

$$\text{Continuous dissipation} = \frac{\text{Short time dissipation}}{\text{Overload factor(OLF)}}$$

Calculation example
given:

wanted:
continuous dissipation

The continuous and the short time dissipation can be calculated as follows:

- Resistor with a short time dissipation of 2,5 kW for 7 s and a total cycle time of 120s
 - The duty cycle factor (DCF) is 7 s : 120 s x 100% = 6%
 - Overload factor (OLF) for 6% DCF, according to table it is 8,2
 - The continuous dissipation is 2,5 kW : 8,2 = 305 W;
 - You need a resistor with a continuous dissipation of at least 300W
- e.g. type GWAD/GYAD 320x80**



Terminal details/ wire cross-section

Rated current and cross section of terminals:

Type	Abbreviation	Rated current in A with 100% DCF	Rated current in A up to 40% DCF	Maximum cross section
porcelain-terminal	PK	16		up to 2,5 mm ²
Device terminals out of polyamid (PA)	G 5	30	38	0,5 – 2,5 (4) mm ² AWG 24 - 12
	G 10	60	75	0,5 – 10 (16) mm ² AWG 20 - 6
cage clamp terminal out of PA	ST2,5	20	25	up to 2,5 (4) mm ² ; AWG 28 - 12
	ST 4	30	38	up to 4,0 (6) mm ² ; AWG 28 – 10
	ST 6	41	52	up to 6 (10) mm ² ; AWG 24 - 8
	ST 10	57	72	up to 10 (16) mm ² ; AWG 24 – 6

The values in brackets are for solid conductors or for single wiring.
More terminal types on request or on demand.

The rated current is calculated in each case due to the Ohm`s law as follows:

$$I = \sqrt{\frac{P}{R}}$$

whereas
P is the power of the resistor and
R is the value of the resistance

Mounting

Please mind the mounting indications in the respective series!
You will find these icons in the data sheets:



Allowable: On horizontal surfaces



Allowable: On vertical surfaces terminals/wires at the bottom



Not allowable: On vertical surfaces terminals/wires at the top, left or right.

Type series GU.. / GZ..

5 – 300 W, IP 00, connection at wires or soldering lugs



GZ 100x33 L



Wirewound mica flat resistor, degree of protection IP00. Maximum width up to 115 mm, maximum length up to 300 mm. Depending upon version either wired with blank (GZ..) or with insulating-oxidized wire (GU..). We fix the blank wire of the standard version by an additional strip of cementing.

③ optional, type designation would be GZU.. or GUU, e.g. GZU 110x40 - 20

Technologies

- superflat construction form
- practically any length or width possible within maximum dimensions
- extremely adjustable to the given space
- outstandingly appropriate for integration
- high pulse power ratings of versions with insulating oxidized wire

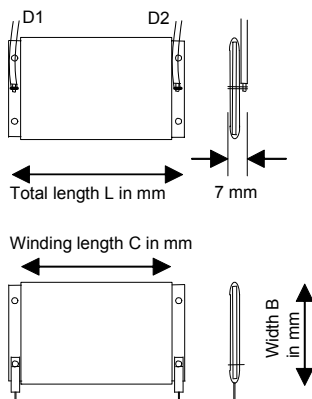

Connection types and versions

Version G...x.. D; (Illustr. s. middle left column, illustr. above) mica flat resistor with connection at 2 hard soldered wires D1 and D2.

Version G...x.. L; (Illustr. s. middle left column, illustr. below) mica flat resistor with 2 soldering lugs (optionally double soldering lugs) as connection points, prepared to be soldered into a printed circuit board.

Dimensioning

Power per wire wound space is valid for a surface excess temperature of 200 K

$$P' = 0,02 \frac{W}{mm^2} = \left(2,0 \frac{W}{cm^2} \right)$$

The total power of a mica flat resistor depends upon the wire wound space.

You can calculate as follows: $A = C \times B$ (dim. in mm)

The total power is therefore $P = P' \times A$ (power in W)

You can calculate the total length as follows :

With $B \geq 33mm$: $L = C + 18mm$, with $B \leq 32mm$: $L = C + 48mm$

The values of P' for short time operation (depending upon DCF) amount to:

DCF	100%	60%	40%	25%	15%	6%
P' (W/mm ²)	0,02	0,03	0,044	0,06	0,084	0,164

These overload factors are valid for a total cycle time of maximum 120 s!

Application

An important application is the use as internal braking resistors as well as series resistors for current limiting when charging the intermediate circuit capacitors of frequency converters.

These resistors are fitting extremely well into the given space. Further application as load or protective resistor.

Special designs

- low noise and low induction
- with centre taps, i.e.. with several partial resistors on one strap

Example of dimensioning and selection of a specific unit:

braking resistor for frequency converter for integration into an enclosure, connection at wires; for short time operation of 180 W at 25% DCF and a total cycle time of 120 s; resistance value 100 Ω; calculation of the necessary space: $A = 180 W : 0,06 W/mm^2 = 3000 mm^2$; the winding length at a supposed width of 50 mm is 60 mm ($3000 mm^2 : 50 mm$). The total length would be 78 mm (60+18 mm distance from edge); type designation would be: GZ 78x50D-100; connection at 2 wires SIF 1,5 mm², each 200 mm long, equipped with conductor sleeves. Resistor rated for 180 W at 25 % DCF, which complies with a continuous dissipation of 60 W

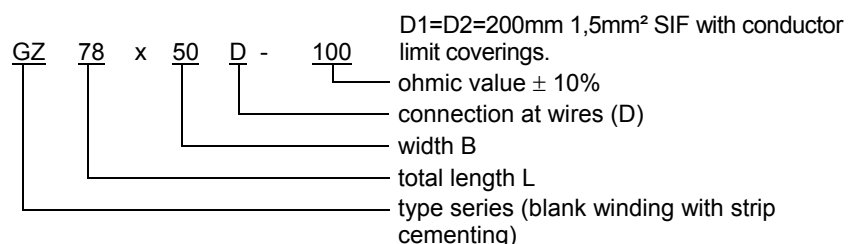



Type series GXTD

30 – 960 W, IP 40, with enclosure

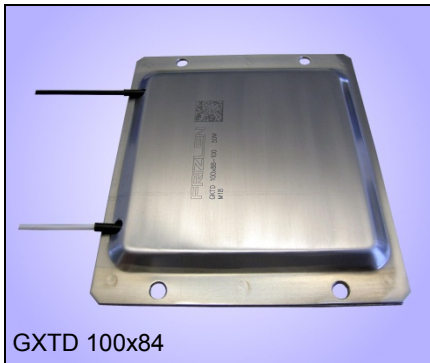

800V
DC

IP
40



Wirewound flat resistor, degree of protection IP 40. Maximum width up to 200 mm, maximum length up to 400 mm. Standard version with aluminium-zink enclosure. With 2 FEP-wires, AWG 18 (0,79 mm²), 0,3 m long.

Technologies

- superflat construction form, max. 5,0 mm
- practically any length or width possible within the maximum dimensions
- extremely adjustable to the given space
- outstandingly appropriate for integration
- higher continuous dissipation by mounting directly onto heat sink or cooling surface
- test voltage for type GXTD is 2,5 kV
- test voltage for optional type GKTD up to 7,7 kV

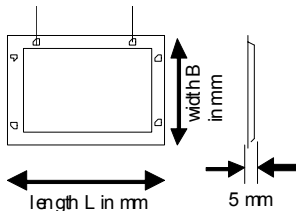

Versions

Standard - design GXTD ..x..

Wirewound mica flat resistor, performed for a test voltage of 2,5 kV, for a DC voltage up to 800 VDC.

At the moment in preparation:

Design GKTD ..x..

Wirewound mica flat resistor, performed for a test voltage of 7,7 kV, for a DC voltage up to 848 VDC.

Dimensioning

The power per space is $P' = 0,012 \frac{W}{mm^2} = \left(1,20 \frac{W}{cm^2} \right)$

The total power of a mica flat resistor depends upon the wire wound space A.

The total power is therefore: $P = P' \times A$ (power in W)
 You can calculate as follows: $A = L \times B$ (dim. in mm)

Application

An important application is the use as internal braking resistors as well as series resistors for current limiting when charging the intermediate circuit capacitors of frequency converters.

These resistors are fitting extremely well into the given space. An additional application is the usage as heat resistor.

Special design

- enclosure made of stainless steel
- connections according to customer wishes, faston receptable, cable lug etc.
- different length of the wires

Example of dimensioning and selection of a specific unit:

Braking resistor for frequency converter for integration into an enclosure, connection with wires; resistance value 100 Ω; continuous dissipation 100 Watt, you can calculate the dimensions: $A = P/P' = 100 W : 0,012 W/mm^2 = 8333 mm^2$. Taking a length with $L=100 mm$, you receive the width $B=A/L = 8333 mm^2 : 100 mm = 83 mm$. So you get the width B 84 mm rounded and a given length L 100 mm.

Type designation for standard-design 2,5 kV test voltage, type is GXTD 100x84-100; connection at 2 wires AWG 18, each 300 mm long.

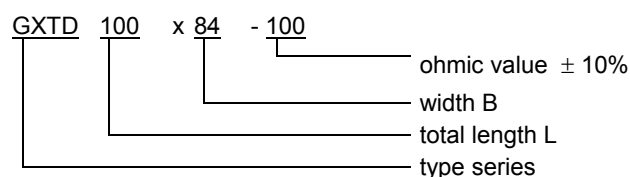

Type series GLAD, GMAD,

40 – 165 W, IP 40, profile x34 and x13

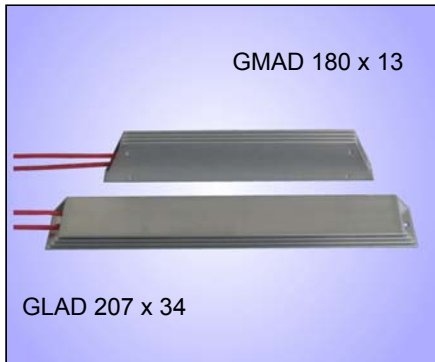

Short-circuit proof wirewound flat resistor, degree of protection IP 40 in blank aluminium enclosure. Design with 2 PTRadox-wires, AWG 18/19 (0,82 mm²), 0,5 m long.

There are 4 versions available: horizontal – type series GLAD
vertical – type series GMAD

③ optionally, type designation would be G.ADU., e.g. GLADU 207x34 - 100

Technologies

- compact construction form in a rectangular profile with rib-shaped cooling
- short-circuit proof
- self-extinguishing
- degree of protection IP 40
- higher continuous dissipation by mounting directly onto heat sink or cooling surface

By mounting directly onto an appropriate cooling surface or onto a heat sink the continuous dissipation can be increased resp. the surface temperature can be lowered. Typical factors for an increase are 1,5 up to 5, depending on type, ventilation and size of the cooling surface or heat sink.

Application

Different applications derive from the various dimensions in width, height and length.

An important application is the use as braking resistor for motor/generator drive of motors with frequency converters. Because of their degree of protection the resistors can perfectly be integrated into frequency converters or switch cabinets.

Electrical and mechanical data

Type	continuous dissipation in W at 40°C, 100% DCF and surface excess temperature of		production range Ω-value		dimensions in mm							weight in g
	200 K typical -power	250 K	from	up to	A	B	C	D	G	H	J	
GLAD 100x34	40	60	1,0	3,3k	100	50	34	13	1,5	88	4,5	100
GLAD 180x34	85	125	1,5	4,7k	180	50	34	13	1,5	168	4,5	150
GLAD 207x34	100	150	2,2	6,8k	207	50	34	13	1,5	195	4,5	180
GLAD 230x34	110	165	3,3	10k	230	50	34	13	1,5	218	4,5	200
GMAD 100x13	40	60	1,0	3,3k	100	65	34	13	1,5	88	4,5	100
GMAD 180x13	85	125	1,5	4,7k	180	65	34	13	1,5	168	4,5	150
GMAD 207x13	100	150	2,2	6,8k	207	65	34	13	1,5	195	4,5	180
GMAD 230x13	110	165	3,3	10k	230	65	34	13	1,5	218	4,5	200

The given power rating values are valid for 100%CD (continuous dissipation). For short time operation you will find the values in the following table as a function of the duty cycle factor (DCF). Just multiply by the corresponding overload factor (OLF). (Also see pages T306E and T307E).

ED	60%	40%	25%	15%	6%	3%	1%
ÜF	1,5	2,2	3,0	4,2	8,2	13	22

These overload factors are valid for a total cycle time of maximum 120 s.

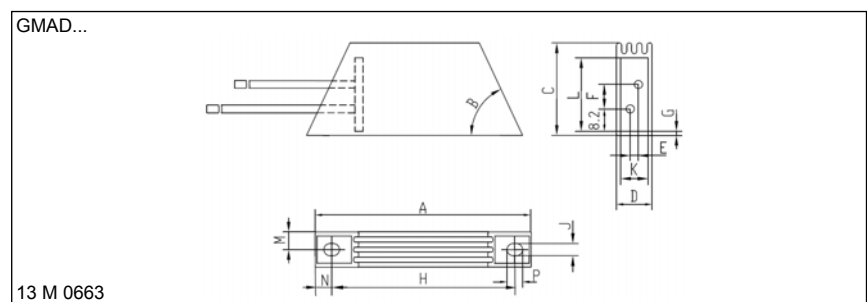
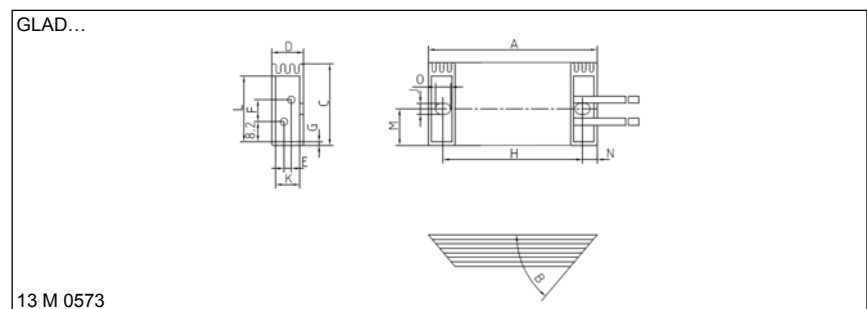

Type series GLAD, GMAD, GNAD, GPAD

50 – 500 W, IP 40, profile x40, x20, x60 and x30

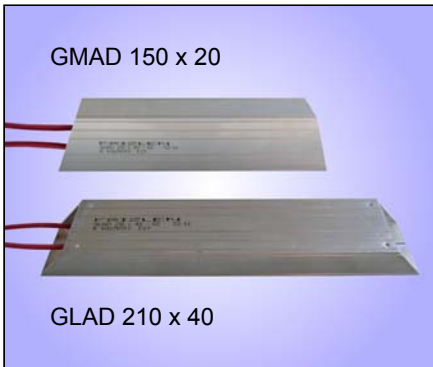

Short-circuit proof wirewound flat resistor, degree of protection IP 40 in blank aluminium enclosure. Design with 2 wires 0,5 m long.

Type series: GLAD, GMAD with 2 Radox-wires, AWG 18/19 (0,82 mm²)

Type series: GNAD, GPAD with 2 FEP-wires, AWG 14/19 (1,9 mm²)

There are 2 versions available: horizontal – type series GLAD, GNAD
vertical – type series GMAD, GPAD

③ optionally, type designation would be G.ADU..., e.g. GLADU 210x40 - 100

Technologies

- compact construction form in a rectangular profile
- short-circuit proof
- self-extinguishing
- degree of protection IP 40
- higher continuous dissipation by mounting directly onto heat sink or cooling surface

By mounting directly onto an appropriate cooling surface or onto a heat sink the continuous dissipation can be increased resp. the surface temperature can be lowered. Typical factors for an increase are 1,5 up to 5, depending on type, ventilation and size of the cooling surface or heat sink.

Option: temperature switch (..Q)

This type can be fitted with a 180° C temperature switch for monitoring, which has 2 connection wires.

Type designation would be: G.ADQ ...

Application

Different applications derive from the various dimensions in width, height and length. We provide e.g. 4 different constructions forms for 155 W.

An important application is the use as braking resistor for motor/generator drive of motors with frequency converters. Because of their degree of protection the resistors can perfectly be integrated into frequency converters or switch cabinets.

Electrical and mechanical data

Type series	continuous dissipation in W at 40°C, 100% DCF and surface excess temperature of 200 K		production range Ω-value		dimensions in mm							weight in g
	typical	250 K	from	up to	A	B	C	D	G	H	J	
GLAD 100x40	50	75	1,0	3,3k	100	45	40	20	2	82	4,3	145
GLAD 150x40	65	100	1,5	4,7k	150	45	40	20	2	132	4,3	215
GLAD 210x40	100	150	2,2	6,8k	210	45	40	20	2	192	4,3	300
GLAD 240x40	120	180	3,3	10k	240	45	40	20	2	222	4,3	340
GLAD 300x40	155	235	4,7	15k	300	45	40	20	2	282	4,3	430
GLAD 360x40	190	285	5,6	18k	360	45	40	20	2	342	4,3	515
GMAD 100x20	50	75	1,0	3,3k	100	65	20	40	2	82	4,3	145
GMAD 150x20	65	100	1,5	4,7k	150	65	20	40	2	132	4,3	215
GMAD 210x20	100	150	2,2	6,8k	210	65	20	40	2	192	4,3	300
GMAD 240x20	120	180	3,3	10k	240	65	20	40	2	222	4,3	340
GMAD 300x20	155	235	4,7	15k	300	65	20	40	2	282	4,3	430
GMAD 360x20	190	285	5,6	18k	360	65	20	40	2	342	4,3	515
GNAD 165x60	110	165	2,2	6,8k	165	60	60	30	3	146	5,3	590
GNAD 215x60	155	235	3,3	10k	215	60	60	30	3	196	5,3	770
GNAD 265x60	200	300	4,7	15k	265	60	60	30	3	246	5,3	950
GNAD 335x60	270	400	6,8	22k	335	60	60	30	3	316	5,3	1200
GNAD 405x60	330	500	8,2	27k	405	60	60	30	3	386	5,3	1450
GPAD 165x30	110	165	2,2	6,8k	165	73	30	60	3	146	5,3	590
GPAD 215x30	155	235	3,3	10k	215	73	30	60	3	196	5,3	770
GPAD 265x30	200	300	4,7	15k	265	73	30	60	3	246	5,3	950
GPAD 335x30	270	400	6,8	22k	335	73	30	60	3	316	5,3	1200
GPAD 405x30	330	500	8,2	27k	405	73	30	60	3	386	5,3	1450

The given power rating values are valid for 100%CD (continuous dissipation). For short time operation you will find the values in the following table as a function of the duty cycle factor (DCF). Just multiply by the corresponding overload factor (OLF). (Also see pages T306E and T307E).

ED	60%	40%	25%	15%	6%	3%	1%
ÜF	1,5	2,2	3,0	4,2	8,2	13	22

These overload factors are valid for a total cycle time of maximum 120 s.

GLAD, GMAD, GNAD, GPAD... (the figure shows the version with temperature switch (Q))

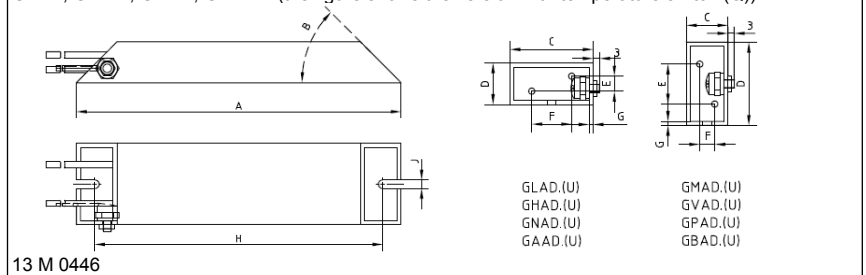

Type series GXAD / GXMD

100 – 300 W, IP 40, profile x70



1100V
DC

848V
DC

IP
40



Short-circuit proof wirewound flat resistor, in blank aluminium enclosure. With different sizes and for different voltages. PT Design with 2 PTFE-wires, AWG 14/19 (mind. 1,9 mm²), 0,5 m long.

Type series: GXAD.. rated voltage max. 848 VDC

Type series: GXMD.. rated voltage max. 1100 VDC

③ optionally with different UL - certification, see page T305E, type designation would be GX.DU..., e.g. GXADU 216x70 - 33

Technologies

- rated voltage max. 1100 VDC
- very flat, compact construction form
- short-circuit proof
- self-extinguishing
- degree of protection IP 40
- higher continuous dissipation by mounting directly onto heat sink or cooling surface
- compact construction form

By mounting directly onto an appropriate cooling surface or onto a heat sink the continuous dissipation can be increased resp. the surface temperature can be lowered. Typical factors for an increase are 1,5 up to 5, depending on type, ventilation and size of the cooling surface or heat sink.

Electrical and mechanical data

Type series	continuous dissipation in W at 40°C, 100% DCF and surface excess temperature of		production range Ω-value		dimensions in mm		weight in g
	200 K typical power	250 K	from	up to	A	B	
GXAD – 848 V GXMD – 1100 V							
GX.D 110 x 70	100	150	2,7	3,3k	110	98	300
GX.D 160 x 70	150	225	4,7	5,6k	160	148	420
GX.D 216 x 70	200	300	6,8	8,2k	216	204	550

The given power rating values are valid for 100%CD (continuous dissipation). For short time operation you will find the values in the following table as a function of the duty cycle factor (DCF). Just multiply by the corresponding overload factor (OLF). (Also see pages T306E and T307E).

ED	60%	40%	25%	15%	6%	3%	1%
ÜF	1,5	2,2	3,0	4,2	8,2	13	22

These overload factors are valid for a total cycle time of maximum 120 s.

Application

E.g. as brake-resistor for frequency converters (fc). Based on the small sizes these resistors can be mounted directly to the housing of a fc.

Special design

- E.g. with higher protection degree IP54/67

You will find further examples on page T317E.

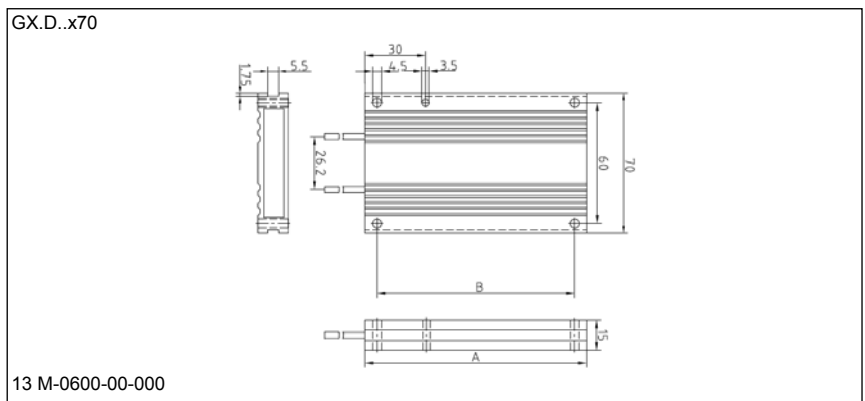

Example of dimensioning and selection of a specific unit:

Braking resistor for frequency converter drive, short time power: 1,2 kW at 6% DCF, total cycle time shorter than 120 s, intermediate voltage circuit 1050 V; resistance value 100 Ω; calculating of continuous dissipation: 1,2 kW : 8,2 = 146 W; degree of protection IP54. Selected: GXMD 160 x 70 – 100 with continuous dissipation 150 W

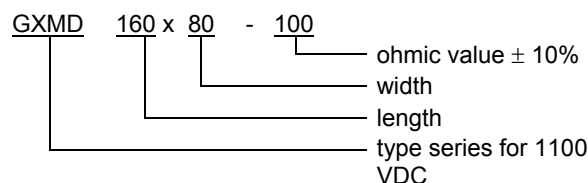



Type series GXAD / GXMD

100 – 450 W, IP 40, profile x80 and x120



1100V
DC

848V
DC

IP
40



Short-circuit proof wirewound flat resistor, in blank aluminium enclosure. With different sizes and for different voltages. PT Design with 2 PTFE-wires, AWG 14/19 (mind. 1,9 mm²), 0,5 m long.

Type series: GXAD.. rated voltage max. 848 VDC

Type series: GXMD.. rated voltage max. 1100 VDC

③ optionally with different UL - certification, on page T305E, type designation would be GX.DU.. or GX.DQU.., e.g. GXADQU 160x80 - 100

Technologies

- rated voltage max. 1100 VDC
- very flat, compact construction form
- short-circuit proof
- self-extinguishing
- degree of protection IP 40
- higher continuous dissipation by mounting directly onto heat sink or cooling surface
- compact construction form

By mounting directly onto an appropriate cooling surface or onto a heat sink the continuous dissipation can be increased resp. the surface temperature can be lowered. Typical factors for an increase are 1,5 up to 5, depending on type, ventilation and size of the cooling surface or heat sink.

We provide various mounting brackets as accessories for different mounting types, see page T350E

Option: temperature switch (..Q)

This type can be fitted with a 180° C temperature switch for monitoring, which has 2 connection wires.

Type designation would be: GX.DQ ...

Application

E.g. as brake-resistor for frequency converters (fc). Based on the small sizes these resistors can be mounted directly to the housing of a fc.

Special design

- E.g. with higher protection degree IP54/67

You will find further examples on page T317E.

Electrical and mechanical data

Type series	continuous dissipation in W at 40°C, 100% DCF and surface excess temperature of		production range Ω-value		dimensions in mm						weight in g	
	200 K typical power	250 K	from	upto	A	B	C	D	E	F		
GXAD – 848V GXMD – 1100V												
GX.D. 110x80	100	150	2,7	3,3k	110	98	60	80	26,2	15	300	
GX.D. 160x80	150	225	4,7	5,6k	160	148	60	80	26,2	15	420	
GX.D. 216x80	200	300	6,8	8,2k	216	204	60	80	26,2	15	550	
GX.D. 216x120	300	450	10,0	12k	216	204	100	120	35,8	20	1100	

The given power rating values are valid for 100%CD (continuous dissipation). For short time operation you will find the values in the following table as a function of the duty cycle factor (DCF). Just multiply by the corresponding overload factor (OLF). (Also see pages T306E and T307E).

ED	60%	40%	25%	15%	6%	3%	1%
ÜF	1,5	2,2	3,0	4,2	8,2	13	22

These overload factors are valid for a total cycle time of maximum 120 s.

GX.D..x80... (the figure shows the version with temperature switch (Q))

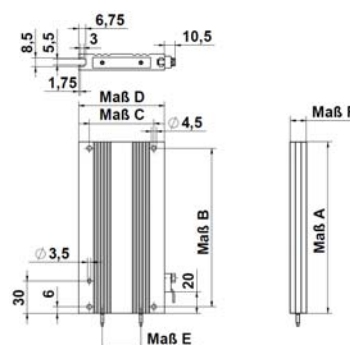

13 M-600-01-000/13 M-0688-02-000

Type series GHAD, GVAD, GAAD, GBAD

50 – 500 W, IP 54, profile x40, x20, x60 and x30

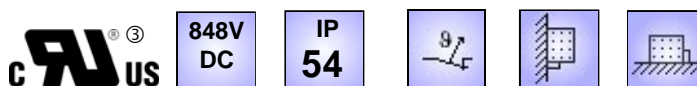
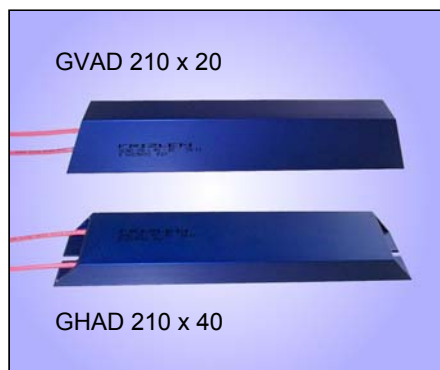

Short-circuit proof wirewound flat resistor, degree of protection IP 54 in blue anodized aluminium enclosure. Design with 2 wires 0,5 m long.

Type series: GHAD, GVAD with 2 Radox-wires, AWG 18/19 (0,82 mm²)

Type series: GAAD, GBAD with 2 FEP-wires, AWG 14/19 (1,9 mm²)

There are 2 versions available: horizontal – type series GHAD, GAAD
vertical – type series GVAD, GBAD

③ optionally, type designation would be G.ADU., e.g. GHADU 240x40-180

Technologies

- compact construction form in a rectangular profile
- short-circuit proof
- self-extinguishing
- degree of protection IP 54
- suited for rough environment
- higher continuous dissipation by mounting directly onto heat sink or cooling surface.

By mounting directly onto an appropriate cooling surface or onto a heat sink the continuous dissipation can be increased resp. the surface temperature can be lowered. Typical factors for an increase are 1,5 up to 5, depending on type, ventilation and size of the cooling surface or heat sink.

Option: Temperature switch (..Q)

This type series can be fitted with a 180°C temperature switch for monitoring, which has 2 connection wires.

Type designation would be: G.ADQ ..

Application

Different applications derive from the various dimensions in width, height and length. We provide e.g. 4 different constructions forms for 155 W.

An important application is the use as braking resistor for motor/generator drive of motors with frequency converters. They are perfectly suited for rough environments because of their high degree of protection. With adequate mechanical protection the resistors can be mounted outside the switch cabinets directly at the fc or motor.

Electrical and mechanical data

Type series	continuous dissipation in W at 40°C, 100%DCF and surface excess temperature of		production range Ω-value		dimensions in mm								weight in g
	200 K typical power-	250 K	from	up to	A	B	C	D	G	H	J		
GHAD. 100x40	50	75	1,0	3,3k	100	45	40	20	2	82	4,3	145	
GHAD. 150x40	65	100	1,5	4,7k	150	45	40	20	2	132	4,3	215	
GHAD. 210x40	100	150	2,2	6,8k	210	45	40	20	2	192	4,3	300	
GHAD. 240x40	120	180	3,3	10k	240	45	40	20	2	222	4,3	340	
GHAD. 300x40	155	235	4,7	15k	300	45	40	20	2	282	4,3	430	
GHAD. 360x40	190	285	5,6	18k	360	45	40	20	2	342	4,3	515	
GVAD. 100x20	50	75	1,0	3,3k	100	45	20	40	2	82	4,3	145	
GVAD. 150x20	65	100	1,5	4,7k	150	65	20	40	2	132	4,3	215	
GVAD. 210x20	100	150	2,2	6,8k	210	65	20	40	2	192	4,3	300	
GVAD. 240x20	120	180	3,3	10k	240	65	20	40	2	222	4,3	340	
GVAD. 300x20	155	235	4,7	15k	300	65	20	40	2	282	4,3	430	
GVAD. 360x20	190	285	5,6	18k	360	65	20	40	2	342	4,3	515	
GAAD. 165x60	110	165	2,2	6,8k	165	60	60	30	3	146	5,3	590	
GAAD. 215x60	155	235	3,3	10k	215	60	60	30	3	196	5,3	770	
GAAD. 265x60	200	300	4,7	15k	265	60	60	30	3	246	5,3	950	
GAAD. 335x60	270	400	6,8	22k	335	60	60	30	3	316	5,3	1200	
GAAD. 405x60	330	500	8,2	27k	405	60	60	30	3	386	5,3	1450	
GBAD. 165x30	110	165	2,2	6,8k	165	73	30	60	3	146	5,3	590	
GBAD. 215x30	155	235	3,3	10k	215	73	30	60	3	196	5,3	770	
GBAD. 265x30	200	300	4,7	15k	265	73	30	60	3	246	5,3	950	
GBAD. 335x30	270	400	6,8	22k	335	73	30	60	3	316	5,3	1200	
GBAD. 405x30	330	500	8,2	27k	405	73	30	60	3	386	5,3	1450	

NOTE: excess temperature values of 200 K should not be exceeded in order not to risk the degree of protection!

The given power rating values are valid for 100%CD (continuous dissipation). For short time operation you will find the values in the following table as a function of the duty cycle factor (DCF). Just multiply by the corresponding overload factor (OLF). (Also see pages T306E and T307E).

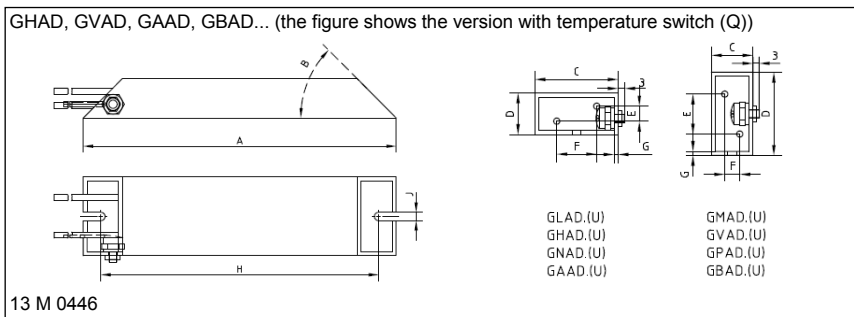



Type series GWAD / GYAD

100 – 750 W, IP 54 or IP 67, profile x80 and x120

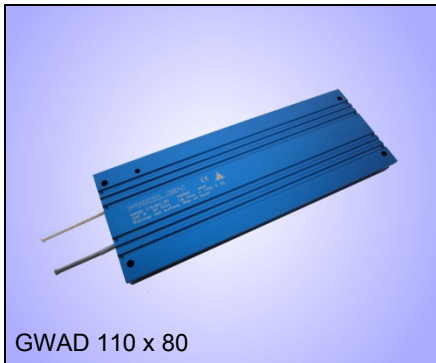

GWAD 110 x 80



Short-circuit proof wirewound flat resistor, in anodized aluminium enclosure. Design with 2 PTFE-wires, AWG 14/19 (1,9 mm²), 0,5 m long.

Version with degree of protection IP 54 – type series GWAD... (standard version)
Version with degree of protection IP 67 – type series GYAD...

© optionally, type designation G.ADU or G.ADQU..., e.g. GWADQU 420x80 - 33

Technologies

- very flat, compact construction form
- short-circuit proof
- self-extinguishing
- degree of protection up to IP 67
- suited for rough environment
- higher continuous dissipation by mounting directly onto heat sink or cooling surface
- easy mounting by T-slot

By mounting directly onto an appropriate cooling surface or onto a heat sink the continuous dissipation can be increased resp. the surface temperature can be lowered. Typical factors for an increase are 1,5 up to 5, depending on type, ventilation and size of the cooling surface or heat sink.

We provide various mounting brackets as accessories for different mounting types, see page T350E.

Option: temperature switch (..Q) (only for type GW..Q.. – not for GY..)

This type can be fitted with a 180° C temperature switch for monitoring which has 2 connection wires.

Type designation would be: GWADQ ...

Application

Braking resistors for frequency converters (fc). They are perfectly suited for rough environments because of their high degree of protection. With adequate mechanical protection of the wires the resistors can be mounted outside the switch cabinets directly at the fc or motor.

Special design

- with terminals, terminal box or screened cable

You will find further examples on page T318E and T340E.

Electrical and mechanical data

Type series	continuous dissipation in W at 40°C, 100% DCF and surface excess temperature of 200 K		production range Ω-value		dimensions in mm						weight in g
	typical power	250 K	from	upto	A	B	C	D	E	F	
GWAD – IP54 GYAD – IP67											
G.AD. 110x80	100	150	2,7	3,3k	110	98	60	80	26,2	15	300
G.AD. 160x80	150	225	4,7	5,6k	160	148	60	80	26,2	15	420
G.AD. 216x80	200	300	6,8	8,2k	216	204	60	80	26,2	15	550
G.AD. 320x80	300	450	10,0	12k	320	2x154	60	80	26,2	15	850
G.AD. 420x80	400	600	12,0	18k	420	2x204	60	80	26,2	15	1100
G.AD. 520x80	500	750	18,0	22k	520	4x127	60	80	26,2	15	1350
G.AD. 216x120	300	450	10,0	12k	216	204	100	120	35,8	20	1100

NOTE: excess temperature values of 200 K should not be exceeded in order not to risk the degree of protection!

The given power rating values are valid for 100%CD (continuous dissipation). For short time operation you will find the values in the following table as a function of the duty cycle factor (DCF). Just multiply by the corresponding overload factor (OLF). (Also see pages T306E and T307E).

	60%	40%	25%	15%	6%	3%	1%
ÜF	1,5	2,2	3,0	4,2	8,2	13	22

These overload factors are valid for a total cycle time of maximum 120 s.

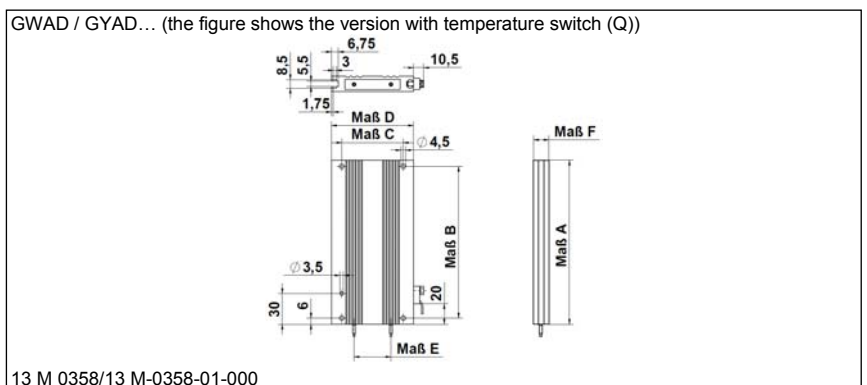

Type series GWAE..

100 – 500 W, IP 54, profile x80,
connection by screened cable

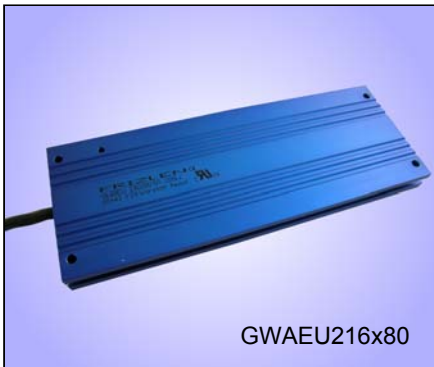

GWAEU216x80



Short-circuit proof wirewound flat resistor with degree of protection IP 54 in blue anodized aluminium enclosure. Design with screened cable PT 3x1,3 mm² (AWG 16/19), 200°C, 0,75 m long.

© optionally, type designation would be GWAEU ...,

Technologies

- very flat, compact construction form
- short-circuit proof
- self-extinguishing
- degree of protection IP 54
- incl. screened cable
- higher continuous dissipation by mounting directly onto heat sink or cooling surface
- easy mounting by T-slot

By mounting directly onto an appropriate cooling surface or onto a heat sink the continuous dissipation can be increased resp. the surface temperature can be lowered. Typical factors for an increase are 1,5 up to 5, depending on type, ventilation and size of the cooling surface or heat sink.

We provide various mounting brackets as accessories for different mounting types; see page T350E for further information.

Application

E.g. as braking resistors for servo- or frequency converters. Due to a screened cable and to the high degree of protection the resistors can also be mounted outside the switch cabinets.

Special design

- longer cable

Electrical and mechanical data

Type series	continuous dissipation in W at 40°C, 100% DCF and surface excess temperature of 200 K	production range Ω-value		dimensions in mm		weight in g
		from	up to	A	B	
GWAE. 110 x 80	100	2,7	3,3k	110	98	380
GWAE. 160 x 80	150	4,7	5,6k	160	148	500
GWAE. 216 x 80	200	6,8	8,2k	216	204	630
GWAE. 320 x 80	300	10,0	12 k	320	2x154	930
GWAE. 420 x 80	400	12,0	18 k	420	2x204	1180
GWAE. 520 x 80	500	18,0	22 k	520	4x127	1430

The given power rating values are valid for 100%CD (continuous dissipation). For short time operation you will find the values in the following table as a function of the duty cycle factor (DCF). Just multiply by the corresponding overload factor (OLF). (Also see pages T306E and T307E).

ED	60%	40%	25%	15%	6%	3%	1%
ÜF	1,5	2,2	3,0	4,2	8,2	13	22

These overload factors are valid for a total cycle time of maximum 120 s.

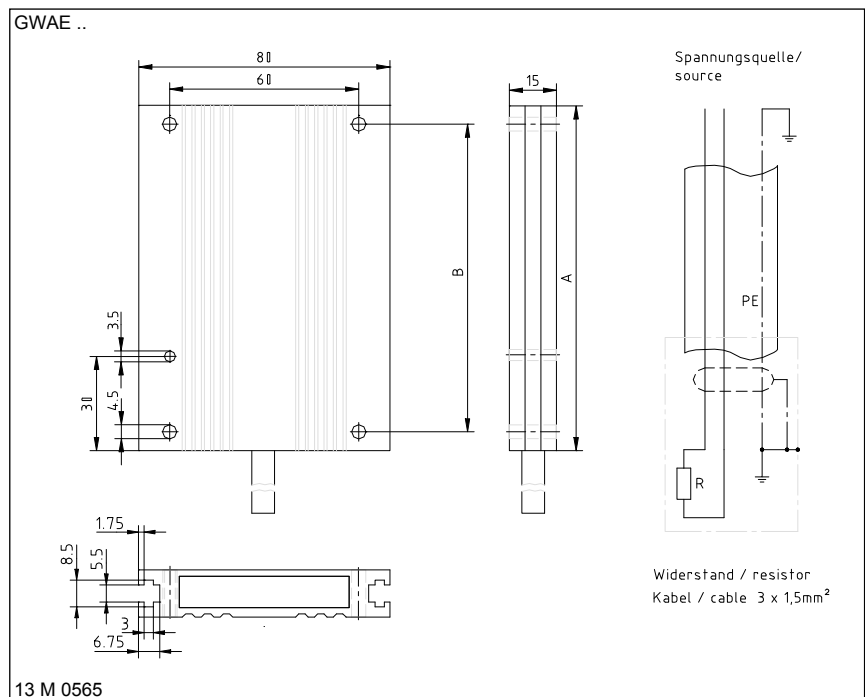



Type series KWAD.. / KYAD..

150 – 1575 W, IP 54 or IP 67,
profile x91

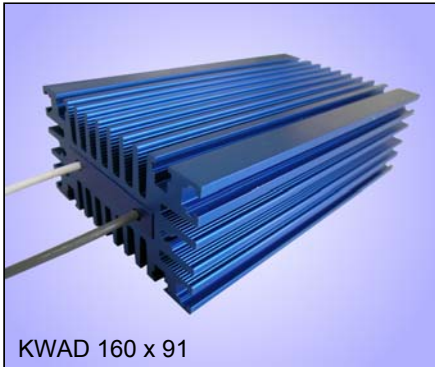

Short-circuit proof wirewound flat resistor in blue anodized aluminium enclosure. Design with 2 PTFE-wires, AWG 14/19 (1,9 mm²), 0,5 m long.

Version with degree of protection IP 54 – type series KWAD.. (standard version)
Version with degree of protection IP 67 – type series KYAD..

③ optionally, type designation would be K.ADU or K.ADQU..., e.g. KWADQU 420x91 - 33

Technologies

- extremely compact construction form
- short-circuit proof
- self-extinguishing
- degree of protection up to IP 67
- suited for rough environment
- easy mounting by T-slot

Please note: The type series K.AD have no mounting holes.

We provide various mounting brackets as accessories for different mounting types; see page T351E – T352 for further information.

Option: Temperature switch (..Q) (only for type KW..Q.. – not for KY..)

This type series can be fitted with a 180°C temperature switch for monitoring which has 2 connection wires.

Type designation would be: KWADQ ...

Application

E.g. as brake resistor for frequency converters (fc). They are perfectly suited for rough environments because of their high degree of protection. With adequate mechanical protection of the wires, the resistors can be mounted outside the switch cabinets directly at the fc or motor.

Special design

- E.g. with terminals, terminal box or screened wiring or in multiple combination for higher dissipation values. See pages T320E and T341E.

Electrical and mechanical data

Type series	continuous dissipation in W at 40°C, 100% DCF and surface excess temperature of		production range Ω-value		dimensions in mm	weight in kg
	200 Ktical power	250 K	from	up to		
KWAD – IP54 KYAD – IP67					A	
K. AD. 110 x 91	150	225	2,7	3,3k	110	0,7
K. AD. 160 x 91	225	340	4,7	5,6k	160	1,0
K. AD. 216 x 91	300	450	6,8	8,2k	216	1,4
K. AD. 320 x 91	450	675	10,0	12 k	320	2,0
K. AD. 420 x 91	600	900	12,0	18 k	420	2,6
K. AD. 520 x 91	750	1125	18,0	22 k	520	3,2
K. AD. 620 x 91	900	1350	22,0	27 k	620	3,8
K. AD. 720 x 91	1050	1575	33,0	33 k	720	4,4

NOTE: excess temperature values of 200 K should not be exceeded in order not to risk the degree of protection!

The given power rating values are valid for 100%CD (continuous dissipation). For short time operation you will find the values in the following table as a function of the duty cycle factor (DCF). Just multiply by the corresponding overload factor (OLF). (Also see pages T306E and T307E).

ED	60%	40%	25%	15%	6%	3%	1%
ÜF	1,5	2,2	3,0	3,6	6,3	9,3	15

These overload factors are valid for a total cycle time of maximum 120 s.

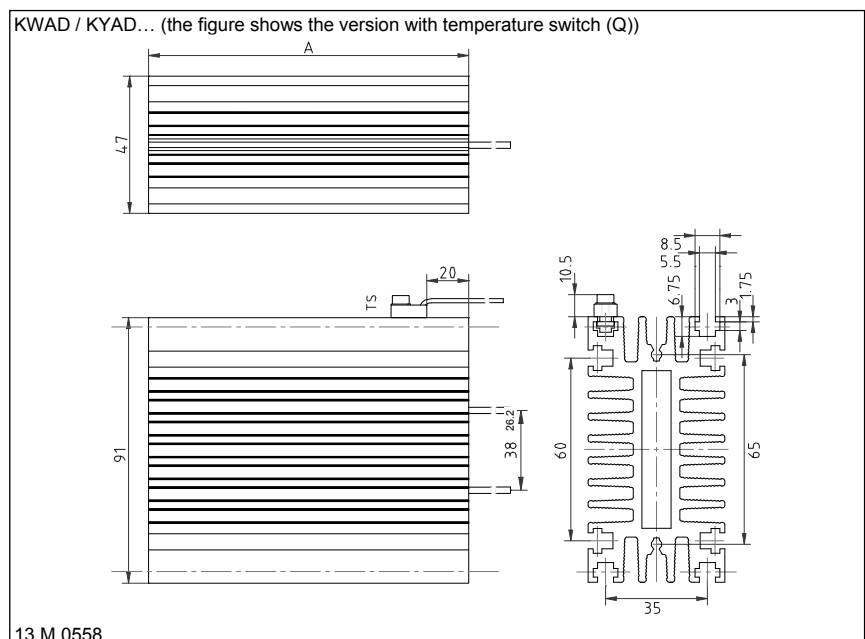

13 M 0558

Type series KWAE..

150 – 1050 W, IP 54, profile x91,
connection by screened cable

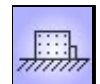
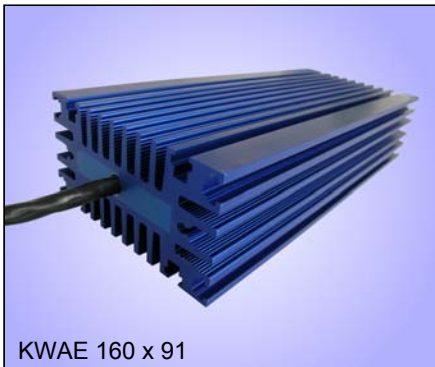

Short-circuit proof wirewound flat resistor with degree of protection 54 in blue anodized aluminium enclosure. Design with screened cable 3x1,3 mm² (AWG 16/19), 200°C, 0,75 m long.

③ optionally, type designation would be KWAEU ...

Technologies

- extremely compact construction form
- short-circuit proof
- self-extinguishing
- degree of protection IP 54
- incl. screened cable
- easy mounting by T-slot

Please note: The type series KWAE have no mounting holes. We provide various mounting brackets as accessories for different mounting types; see page T351E – T352 for further information.

Application

E.g. as brake resistor for servo- or frequency converters. Due to the screened cable and to the high degree of protection the resistors also can be mounted outside of switch cabinets.

Special design

- longer cable

Electrical and mechanical data

Type series	continuous dissipation in W at 40°C, 100%DCF and surface excess temperature of 200 K	production range Ω-value		dimensions in mm A	weight in kg
		from	up to		
KWAE. 110 x 91	150	2,7	3,3k	110	0,8
KWAE. 160 x 91	225	4,7	5,6k	160	1,1
KWAE. 216 x 91	300	6,8	8,2k	216	1,5
KWAE. 320 x 91	450	10,0	12 k	320	2,1
KWAE. 420 x 91	600	12,0	18 k	420	2,7
KWAE. 520 x 91	750	18,0	22 k	520	3,3
KWAE. 620 x 91	900	22,0	27 k	620	3,9
KWAE. 720 x 91	1050	33,0	33 k	720	4,5

The given power rating values are valid for 100%CD (continuous dissipation). For short time operation you will find the values in the following table as a function of the duty cycle factor (DCF). Just multiply by the corresponding overload factor (OLF). (Also see pages T306E and T307E).

ED	60%	40%	25%	15%	6%	3%	1%
ÜF	1,5	2,2	3,0	3,6	6,3	9,3	15

These overload factors are valid for a total cycle time of maximum 120 s.

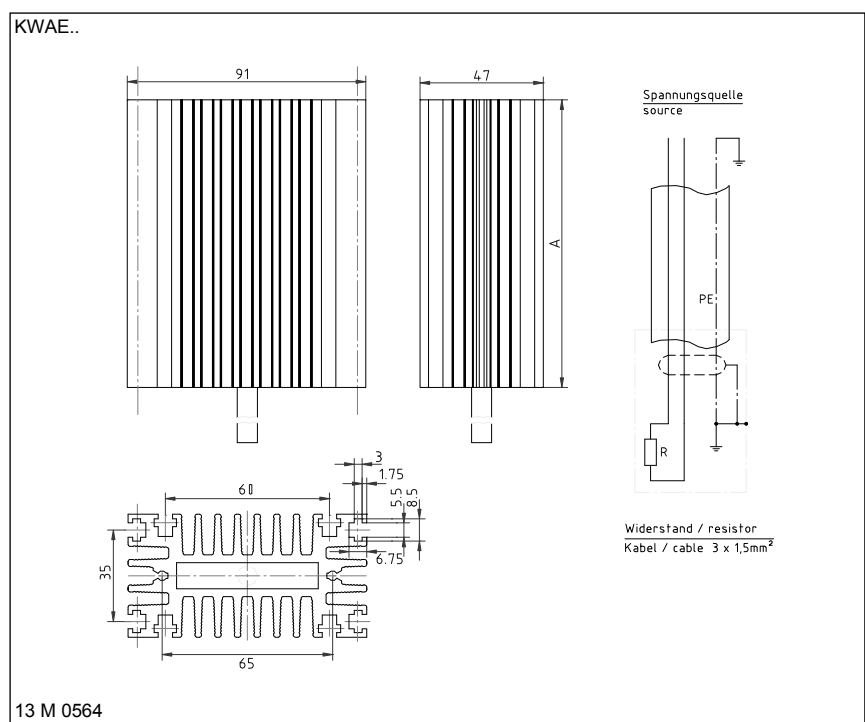

Type series GAMD, GBMD

110 – 500 W, IP 54, profile x60 and x30



Short-circuit proof wirewound flat resistor, degree of protection IP 54 in blue anodized aluminium enclosure. Design with 2 FEP-wires, AWG 14/19 (2,1 mm²), 1000 V, 0,5 m long.

There are 2 versions available: horizontal – type series GAMD
vertical – type series GBMD

③ optionally, type designation would be G.MDU..., e.g. GAMDU 215x60 - 180

Technologies

- rated voltage max. 1100 VDC
- compact construction form in a rectangular profile
- short-circuit proof
- self-extinguishing
- protection degree IP 54
- usable in harsh environment
- higher continuous dissipation by mounting directly onto heat sink or cooling surface

By mounting directly onto an appropriate cooling surface or onto a heat sink the continuous dissipation can be increased resp. the surface temperature can be lowered. Typical factors for an increase are 1,5 up to 5, depending on type, ventilation and size of the cooling surface or heat sink.

Option: temperature switch (..Q)

This type can be fitted with a 180° C temperature switch for monitoring, which has 2 connection wires.

Type designation would be: G.MDQ ...

Application

Different applications derive from the various dimensions in width, height and length.

An important application is the use as braking resistor for motor/generator drive of motors with frequency converters. This type series is for frequency converters with higher voltage. With adequate mechanical protection the resistors can be mounted outside the switch cabinets directly at the fc or motor.

Electrical and mechanical data

Type series	continuous dissipation in W at 40°C, 100% DCF and surface excess temperature of		production range Ω-value		dimensions in mm							weight in g
	200 K Typical power	250 K	from	up to	A	B	C	D	G	H	J	
GAMD. 165x60	110	165	2,2	6,8k	165	60	60	30	3	146	5,3	590
GAMD. 215x60	155	235	3,3	10k	215	60	60	30	3	196	5,3	770
GAMD. 265x60	200	300	4,7	15k	265	60	60	30	3	246	5,3	950
GAMD. 335x60	270	400	6,8	22k	335	60	60	30	3	316	5,3	1200
GAMD. 405x60	330	500	8,2	27k	405	60	60	30	3	386	5,3	1450
GBMD. 165x30	110	165	2,2	6,8k	165	73	30	60	3	146	5,3	590
GBMD. 215x30	155	235	3,3	10k	215	73	30	60	3	196	5,3	770
GBMD. 265x30	200	300	4,7	15k	265	73	30	60	3	246	5,3	950
GBMD. 335x30	270	400	6,8	22k	335	73	30	60	3	316	5,3	1200
GBMD. 405x30	330	500	8,2	27k	405	73	30	60	3	386	5,3	1450

Note: Excess temperature values of 200 K should not be exceeded in order not to risk the degree of protection!

The given power rating values are valid for 100%CD (continuous dissipation). For short time operation you will find the values in the following table as a function of the duty cycle factor (DCF). Just multiply by the corresponding overload factor (OLF). (Also see pages T306E and T307E).

ED	60%	40%	25%	15%	6%	3%	1%
ÜF	1,5	2,2	3,0	4,2	8,2	13	22

These overload factors are valid for a total cycle time of maximum 120 s.

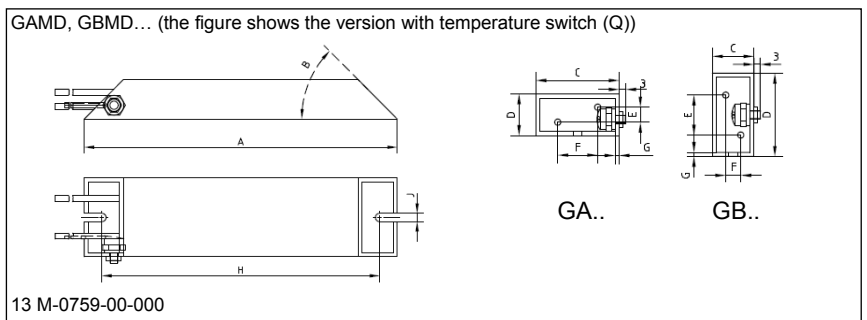

Type series GWMD / GYMD

100 – 750 W, IP 54 or IP 67, profile x80 and x120

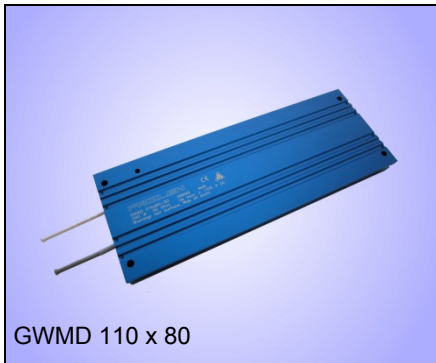

GWMD 110 x 80



Short-circuit proof wirewound flat resistor, design with 2 FEP-wires, AWG 14/19 (2,1 mm²), 1000 V, 0,5 m long.

Version with degree of protection IP 54 – type GWMD... (standard version)
Version with degree of protection IP 67 – type GYMD...

③ optionally, type designation would be G.MDU or GWMDQU...
e.g. GWMDQU 420x80 - 33

Technologies

- rated voltage max. 1100 VDC
- very flat, compact construction form
- short-circuit proof
- self-extinguishing
- degree of protection IP 54
- usable in harsh environment
- higher continuous dissipation by mounting directly onto heat sink or cooling surface
- easy mounting by T-slot

By mounting directly onto an appropriate cooling surface or onto a heat sink the continuous dissipation can be increased resp. the surface temperature can be lowered. Typical factors for an increase are 1,5 up to 5, depending on type, ventilation and size of the cooling surface or heat sink.

We provide various mounting brackets as accessories for different mounting types; see page T350E for further information.

**Option: Temperature switch (..Q)
(only for type GWMDQ.. – not for GYMD)**

This type can be fitted with a 180° C temperature switch for monitoring, which has 2 connection wires.
Type designation would be: GWMDQ ...

Application

E.g. as brake resistor for frequency converters (fc). They are perfectly suited for rough environments because of their high degree of protection. With adequate mechanical protection of the wires the resistors can be mounted outside the switch cabinets directly at the fc or motor.

Electrical and mechanical data

Type series	continuous dissipation in W at 40°C, 100% DCF and surface excess temperature of		production range Ω-value		dimensions in mm						weight in g
	200 K Typical power	250 K	from	up to	A	B	C	D	E	F	
GWMD – IP54 GYMD – IP67											
G.MD. 110x80	100	150	2,7	3,3k	110	98	60	80	26,2	15	300
G.MD. 160x80	150	225	4,7	5,6k	160	148	60	80	26,2	15	420
G.MD. 216x80	200	300	6,8	8,2k	216	204	60	80	26,2	15	550
G.MD. 320x80	300	450	10,0	12k	320	2x154	60	80	26,2	15	850
G.MD. 420x80	400	600	12,0	18k	420	2x204	60	80	26,2	15	1100
G.MD. 520x80	500	750	18,0	22k	520	4x127	60	80	26,2	15	1350
G.MD. 216x120	300	450	10,0	12k	216	204	100	120	35,8	20	1100

Note: Excess temperature values of 200 K should not be exceeded in order not to risk the degree of protection!

The given power rating values are valid for 100%CD (continuous dissipation). For short time operation you will find the values in the following table as a function of the duty cycle factor (DCF). Just multiply by the corresponding overload factor (OLF). (Also see pages T306E and T307E).

ED	60%	40%	25%	15%	6%	3%	1%
ÜF	1,5	2,2	3,0	4,2	8,2	13	22

These overload factors are valid for a total cycle time of maximum 120 s.

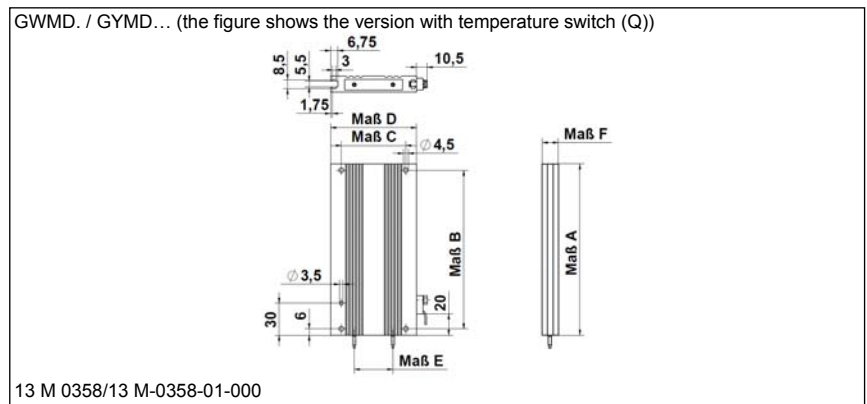



Type series KWMD.. / KYMD..

150 – 1575 W, IP 54 or IP 67,
profile x91

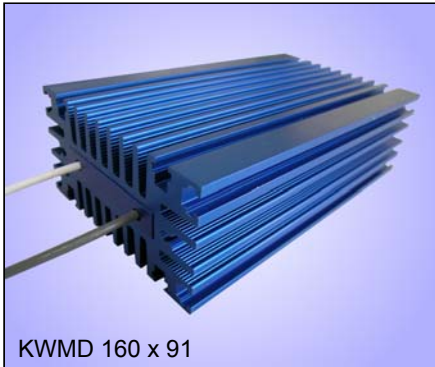

Short-circuit proof wirewound flat resistor, design with 2 FEP-wires, AWG 14/19 (2,1 mm²), 1000 V, 0,5 m long.

Version with degree of protection IP 54 – type KWMD... (standard version)
Version with degree of protection IP 67 – type KYMD...

© optionally, type designation would be K.MDU or KWMDQU..., e.g. KWMDQU 420x91 - 33

Technologies

- rated voltage max. 1100 VDC
- extremely compact construction form
- short-circuit proof
- self-extinguishing
- degree of protection up to IP 67
- suited for rough environment
- easy mounting by T-slot

Please note: The type series K.MD have no mounting holes.

We provide various mounting brackets as accessories for different mounting types; see page T351E – T352 for further information.

Option: Temperature switch (..Q) (only for Type KW..Q.. – not for KY..)

This type can be fitted with a 180° C temperature switch for monitoring, which has 2 connection wires.

Type designation would be: KWMDQ ...

Application

E.g. as brake resistor for frequency converters (fc). They are perfectly suited for rough environments because of their high degree of protection. With adequate mechanical protection of the wires the resistors can be mounted outside the switch cabinets directly at the fc or motor.

Electrical and mechanical data

Type series	continuous dissipation in W at 40°C, 100% DCF and surface excess temperature of		production range Ω-value		dimensions in mm	weight in kg
	200 Kical power	250 K	from	up to		
KWMD – IP54 KYMD – IP67					A	
K. MD. 110 x 91	150	225	2,7	3,3k	110	0,7
K. MD. 160 x 91	225	340	4,7	5,6k	160	1,0
K. MD. 216 x 91	300	450	6,8	8,2k	216	1,4
K. MD. 320 x 91	450	675	10,0	12 k	320	2,0
K. MD. 420 x 91	600	900	12,0	18 k	420	2,6
K. MD. 520 x 91	750	1125	18,0	22 k	520	3,2
K. MD. 620 x 91	900	1350	22,0	27 k	620	3,8
K. MD. 720 x 91	1050	1575	33,0	33 k	720	4,4

Note: Excess temperature values of 200 K should not be exceeded in order not to risk the degree of protection!

The given power rating values are valid for 100%CD (continuous dissipation). For short time operation you will find the values in the following table as a function of the duty cycle factor (DCF). Just multiply by the corresponding overload factor (OLF). (Also see pages T306E and T307E).

ED	60%	40%	25%	15%	6%	3%	1%
ÜF	1,5	2,2	3,0	3,6	6,3	9,3	15

These overload factors are valid for a total cycle time of maximum 120 s.

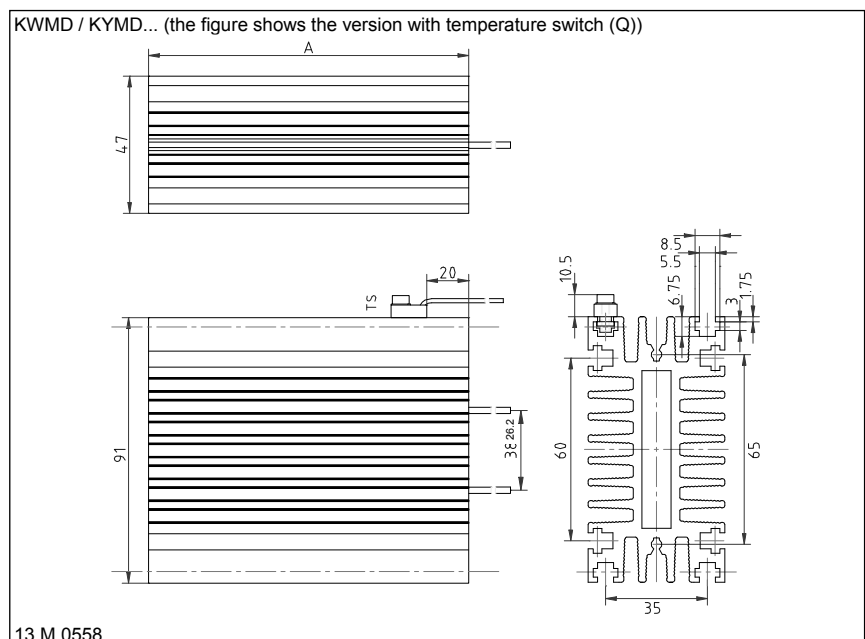

Type series GAND, GBND

110 – 500 W, IP 54, profile x60 and x30



GBND 405 x 30



Short-circuit proof wirewound flat resistor, degree of protection IP 54 in blue anodized aluminium enclosure. Design with 2 FEP-wires, AWG 14/19 (2,1 mm²), 1000 V, 0,5 m long.

There are 2 versions available: horizontal – type series GAND
vertical – type series GBND

③ optionally, type designation would be G.NDU..., e.g. GANDU 215x60 - 82

Besondere Merkmale

- rated voltage max. 1400 VDC
- compact construction form in a rectangular profile
- short-circuit proof
- self-extinguishing
- protection degree IP 54
- usable in harsh environment
- higher continuous dissipation by mounting directly onto heat sink or cooling surface

By mounting directly onto an appropriate cooling surface or onto a heat sink the continuous dissipation can be increased resp. the surface temperature can be lowered. Typical factors for an increase are 1,5 up to 5, depending on type, ventilation and size of the cooling surface or heat sink.

Option: temperature switch (..Q)

This type can be fitted with a 180° C temperature switch for monitoring. which has 2 connection wires.

Type designation would be: G.NDQ ...

Application

Different applications derive from the various dimensions in width, height and length.

An important application is the use as braking resistor for motor/generator drive of motors with frequency converters. This type series is for frequency converters with higher voltage. They are perfectly suited for rough environments because of their high degree of protection. With adequate mechanical protection the resistors can be mounted outside the switch cabinets directly at the fc or motor.

Special design

- Mit Temperaturschalter (Type G.ADQ ..)

Electrical and mechanical data

Type series	continuous dissipation in W at 40°C, 100% DCF and surface excess temperature of 200 K 250 K		production-range Ω-value		dimensions in mm								weight in g
	Typical - power		from	upto	A	B	C	D	G	H	J		
GAND. 165x60	110	165	2,2	6,8k	165	60	60	30	3	146	5,3	590	
GAND. 215x60	155	235	3,3	10k	215	60	60	30	3	196	5,3	770	
GAND. 265x60	200	300	4,7	15k	265	60	60	30	3	246	5,3	950	
GAND. 335x60	270	400	6,8	22k	335	60	60	30	3	316	5,3	1200	
GAND. 405x60	330	500	8,2	27k	405	60	60	30	3	386	5,3	1450	
GBND. 165x30	110	165	2,2	6,8k	165	73	30	60	3	146	5,3	590	
GBND. 215x30	155	235	3,3	10k	215	73	30	60	3	196	5,3	770	
GBND. 265x30	200	300	4,7	15k	265	73	30	60	3	246	5,3	950	
GBND. 335x30	270	400	6,8	22k	335	73	30	60	3	316	5,3	1200	
GBND. 405x30	330	500	8,2	27k	405	73	30	60	3	386	5,3	1450	

Note: Excess temperature values of 200 K should not be exceeded in order not to risk the degree of protection!

The given power rating values are valid for 100%CD (continuous dissipation). For short time operation you will find the values in the following table as a function of the duty cycle factor (DCF). Just multiply by the corresponding overload factor (OLF). (Also see pages T306E and T307E).

ED	60%	40%	25%	15%	6%	3%	1%
ÜF	1,5	2,2	3,0	4,2	8,2	13	22

These overload factors are valid for a total cycle time of maximum 120 s.

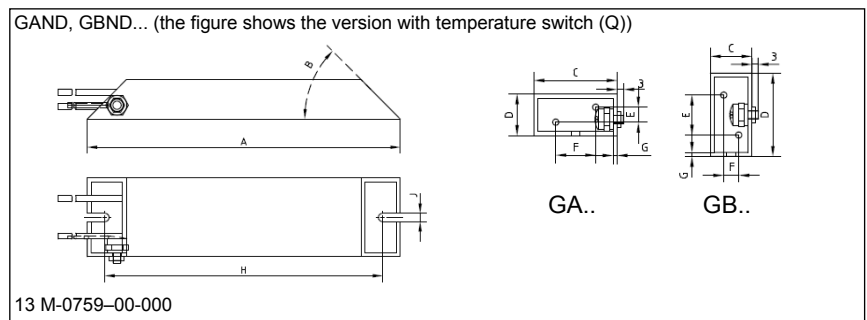



Type series GAPD, GBPD

200 - 300 W, IP 54, profile x60 and x30

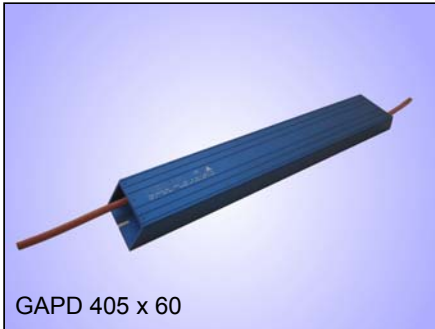

4200V
DC

IP
54



Short-circuit proof wirewound flat resistor, degree of protection IP 54 in blue anodized aluminium enclosure. Design with 0,5 m length of silicone isolated neon cable FZLSi 1,0 mm².

There are 2 versions available:

horizontal – type series GAPD
vertical – type series GBPD

Technologies

- rated voltage max. 4200 VDC
- compact construction form in a rectangular profile
- short-circuit proof
- self-extinguishing
- protection degree IP 54
- usable in harsh environment
- higher continuous dissipation by mounting directly onto heat sink or cooling surface

By mounting directly onto an appropriate cooling surface or onto a heat sink the continuous dissipation can be increased resp. the surface temperature can be lowered. Typical factors for an increase are 1,5 up to 3, depending on type, ventilation and size of the cooling surface or heat sink.

Application

An important application is the use as resistor for charging- and discharging for higher voltage. They are perfectly suited for rough environments because of their high degree of protection. With adequate mechanical protection the resistors can be mounted outside the switch cabinets.

Electrical and mechanical data

Type series	continuous dissipation in W at 40°C, 100% DCF and surface excess temperature of		production-range Ω-value		dimensions in mm								weight in g
	200 K typical-power	250 K	from	upto	A	B	C	D	E	F	H		
GAPD 405x60	200	300	3,9	10k	405	60	60	30	0	13,5	386	1450	
GBPD 405x30	200	300	3,9	10k	405	73	30	60	13,5	0	386	1450	

Note: Excess temperature values of 200 K should not be exceeded in order not to risk the degree of protection!

The given power rating values are valid for 100%CD (continuous dissipation). For short time operation you will find the values in the following table as a function of the duty cycle factor (DCF). Just multiply by the corresponding overload factor (OLF). (Also see pages T306E and T307E).

ED	60%	40%	25%	15%	6%	3%	1%
ÜF	1,5	2,2	3,0	4,2	8,2	13	22

These overload factors are valid for a total cycle time of maximum 120 s.

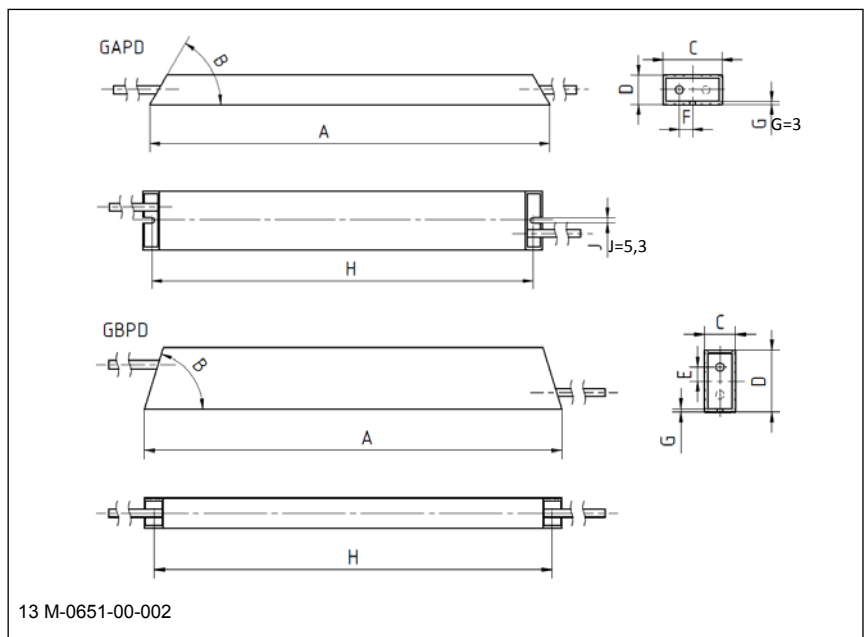

Type series GXHM../GXUM..

100 – 750 W, up to IP 40 in aluminium enclosure, connection at terminals



GXHMQ216x80



Short-circuit proof wirewound flat resistor in blue anodized aluminium enclosure. Prepared to connect screened cable on porcelain terminal. Design with strain relief and ground connection.

GXHM.. for integration into switch cabinet

Resistor with degree of protection IP 40, terminals protected against access according to BGV A2

GXUM.. for mounting outside the switch cabinet

Design as GXHM but terminals in terminal box, degree of protection IP 20

③ optionally, type designation would be GXHM(Q)U.., e.g. GXHMQU 420x80-33 (version with terminals G10/G5)

Technologies

- very flat, compact construction form
- short-circuit proof
- self-extinguishing
- connection option for screened wiring
- GXUM.. with covered terminal box
- higher continuous dissipation by mounting direct up onto heat sink or cooling surface
- easy mounting by T-slot

By mounting directly onto an appropriate cooling surface or onto a heat sink the continuous dissipation can be increased resp. the surface temperature can be lowered. Typical factors for an increase are 1,5 up to 5, depending on type, ventilation and size of the cooling surface or heat sink.

We provide various mounting brackets as accessories for different mounting types; see page T350E for further information.

Option: temperature switch (..Q)

Both type series can be fitted with a 180°C temperature switch for monitoring which is connected to 2 terminals.

Type designation would be: GXHMQ ... or GXUMQ..

Application

e.g. as braking resistors for servo- or frequency converters. Due to optional screened wiring and to space saving construction form protection against access to hazardous parts is ensured also at limited mounting spaces.

Special design

- Resistor with degree of protection IP 54 (GW...)

Electrical and mechanical data

type series	continuous dissipation in W at 40°C, 100% DCF and surface excess temperature of		production range Ω-value		dimensions in mm			weight in g
	200 K typical power	250 K	from	up to	A	B	C _{max}	
GX. M. 110 x 80	100	150	2,7	3,3k	110	98	185	300
GX. M. 160 x 80	150	225	4,7	5,6k	160	148	255	420
GX. M. 216 x 80	200	300	6,8	8,2k	216	204	291	550
GX. M. 320 x 80	300	450	10,0	12 k	320	2x154	395	850
GX. M. 420 x 80	400	600	12,0	18 k	420	2x204	495	1100
GX. M. 520 x 80	500	750	18,0	22 k	520	4x127	595	1350

NOTE: excess temperature values of 200 K should not be exceeded in order not to risk the degree of protection!

The given power rating values are valid for 100%CD (continuous dissipation). For short time operation you will find the values in the following table as a function of the duty cycle factor (DCF). Just multiply by the corresponding overload factor (OLF). (Also see pages T306E and T307E).

DCF	60%	40%	25%	15%	6%	3%	1%
OLF	1,5	2,2	3,0	4,2	8,2	13	22

These overload factors are valid for a total cycle time of maximum 120 s

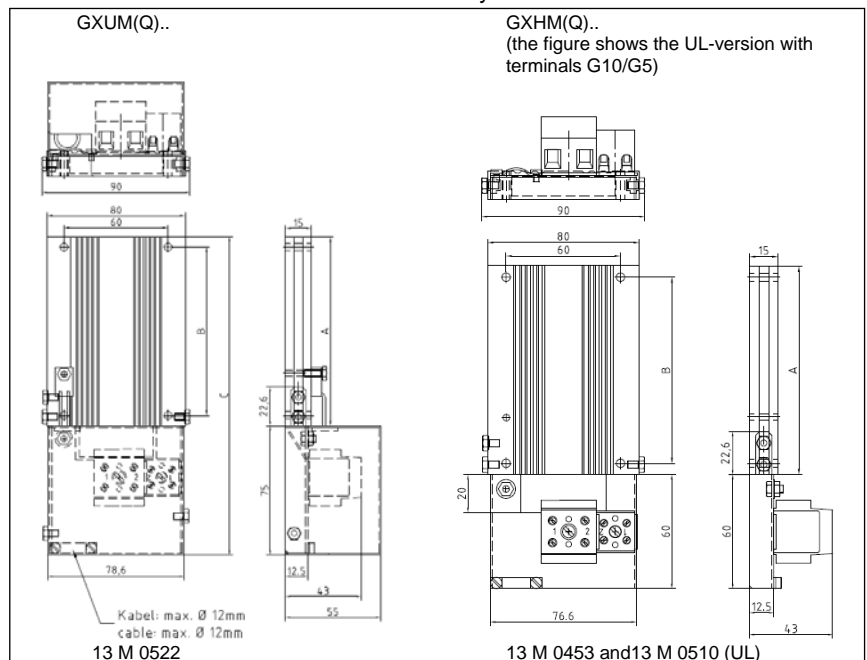



Type series FDWZ.. / FYWZ..

225 – 2520 W, IP 54 or IP65, in aluminium enclosure, with terminals and terminal box



Short-circuit proof wirewound flat resistor in single, double or triple configuration. Degree of protection IP 54 or IP 65 in blue anodized aluminium enclosure. Design with terminals and strain relief by cable inlet in terminal box.

Version with protection degree IP 54 – type FDWZ.. (standard version)
Version with protection degree IP 65 – type FYWZ..

Technologies

- compact construction form
- short-circuit proof
- self-extinguishing
- degree of protection IP 54 or IP 65
- incl. terminals in terminal box

All connections are wired to G10 terminals in the mounted terminal box. A M25 cable gland can be used for cable inlet and strain relief.

Option: Temperature switch (..Q)
(only for type series FDWZ.. – not for FYWZ..)

This type series can be fitted with a 180°C temperature switch for monitoring, which is wired on two terminals in the terminal box.

Type designation would be: FDWZQ...

Application

E.g. as brake resistor for servo- or frequency converters. Due to the terminals in the terminal box various connection conditions and a high degree of protection can be realized at the same time. Thus the resistors also can be mounted outside of switch cabinets at various environment conditions.

Special design

- optionally with connection cable, screened or unscreened
- optionally for 1100V DC

Electrical and mechanical data

Type series	continuous dissipation in W at 40°C, 100% DCF and surface excess temperature of 200 K	production range Ω -value		dimensions in mm						weight in kg
		from	tp to	A	B	C	D	E	F	
F.WZ.51201..	225	4,7	5,6k	245	100	34	90	110	90	1,9
F.WZ.51301..	300	6,8	8,2k	301	100	34	146	110	90	2,3
F.WZ.51401..	450	10,0	12 k	405	100	34	250	110	90	2,9
F.WZ.51501..	600	12,0	18 k	505	100	74	270	110	90	3,5
F.WZ.51601..	750	18,0	22 k	605	100	74	370	110	90	4,1
F.WZ.51701..	900	22,0	27 k	705	100	74	470	110	90	4,8
F.WZ.51801..	1050	33,0	33 k	805	100	74	570	110	90	5,4
F.WZ.51202..	360	4,7	5,6k	245	160	34	90	190	170	3,3
F.WZ.51302..	480	6,8	8,2k	301	160	34	146	190	170	4,0
F.WZ.51402..	720	10,0	12 k	405	160	34	250	190	170	5,2
F.WZ.51502..	960	12,0	18 k	505	160	74	270	190	170	6,5
F.WZ.51602..	1200	18,0	22 k	605	160	74	370	190	170	7,7
F.WZ.51702..	1440	22,0	27 k	705	160	74	470	190	170	9,0
F.WZ.51802..	1680	33,0	33 k	805	160	74	570	190	170	10,2
F.WZ.51203..	540	4,7	5,6k	245	200	34	90	270	250	4,7
F.WZ.51303..	720	6,8	8,2k	301	200	34	146	270	250	5,7
F.WZ.51403..	1080	10,0	12 k	405	200	34	250	270	250	7,7
F.WZ.51503..	1440	12,0	18 k	505	200	74	270	270	250	9,6
F.WZ.51603..	1800	18,0	22 k	605	200	74	370	270	250	11,4
F.WZ.51703..	2160	22,0	27 k	705	200	74	470	270	250	13,3
F.WZ.51803..	2520	33,0	33 k	805	200	74	570	270	250	15,2

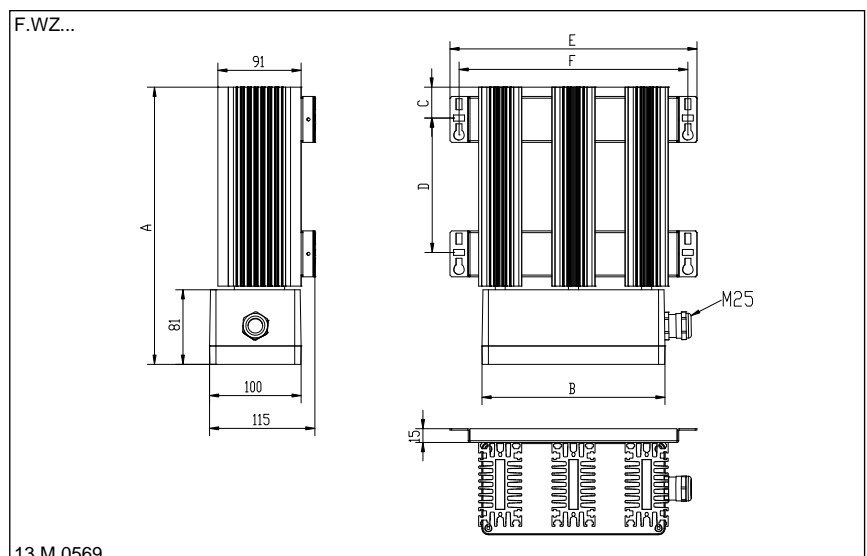

Type series FDAZ.. / FYAZ..

160 – 4800 W, IP 54 or IP65, in aluminium enclosure, with terminals and terminal box



Short-circuit proof wirewound flat resistor in multiple configuration. Degree of protection IP 54 or IP 65 in blue anodized aluminium enclosure. Design with terminals and strain relief provision in terminal box.

Version with protection degree IP 54 – type FDAZ.. (standard version)
Version with protection degree IP 65 – type FYAZ..

Technologies

- compact construction form
- short-circuit proof
- self-extinguishing
- degree of protection IP 54 or IP 65
- incl. terminals in terminal box

All connections run on ST terminals in the mounted terminal box. Cable gland M25 (up to 2,4 kW cont.diss.) or M32 can be used for cable inlet and strain relief.

Option: Temperature switch (..Q)
(only for type series FDAZ.. – not for FYAZ..)

This type series can be fitted with a 180°C temperature switch for monitoring (incl. M12 or M20 cable gland), which is wired on two terminals in the terminal box.

Type designation would be: FDAZQ...

Electrical and mechanical data

Type series	continuous dissipation in W at 40°C, 100%DCF and surface excess temperature of 200 K	production range Ω-value		dimensions in mm						weight in kg
		from	up to	L	H	M	O	R	U	
F.AZ.52102..	160	1,5	8,2 k	211	120	226	290	92	64	2,3
F.AZ.52202..	240	2,7	5,6 k	261	120	276	340	92	64	2,6
F.AZ.52302..	320	3,9	3,9 k	311	120	326	390	92	64	2,9
F.AZ.52502..	640	6,8	2,2 k	511	120	526	590	92	64	3,8
F.AZ.52602..	800	10,0	1,8 k	611	120	626	690	92	64	4,5
F.AZ.52204..	480	1,2	2,7 k	261	120	276	340	185	150	3,6
F.AZ.52304..	640	1,8	2,2 k	311	120	326	390	185	150	4,2
F.AZ.52504..	1280	3,3	1,0 k	511	120	526	590	185	150	6,7
F.AZ.52604..	1600	4,7	820	611	120	626	690	185	150	7,9
F.AZ.52506..	1920	2,2	680	511	120	526	610	275	240	9,2
F.AZ.52606..	2400	3,3	560	611	120	626	710	275	240	10,9
F.AZ.52508..	2560	1,5	560	511	210	526	610	185	150	11,6
F.AZ.52608..	3200	2,2	390	611	210	626	710	185	150	13,9
F.AZ.52512..	3840	1,2	330	511	210	526	610	266	240	16,2
F.AZ.52612..	4800	1,5	270	611	210	626	710	266	240	19,5

Application

E.g. as brake resistor for servo- or frequency converters. Due to the terminals in the terminal box various connection conditions and a high degree of protection can be realized at the same time. Thus the resistors also can be mounted outside of switch cabinets at various environment conditions.

Special design

- optionally with connection cable, screened or unscreened
- optionally up to 1100V DC

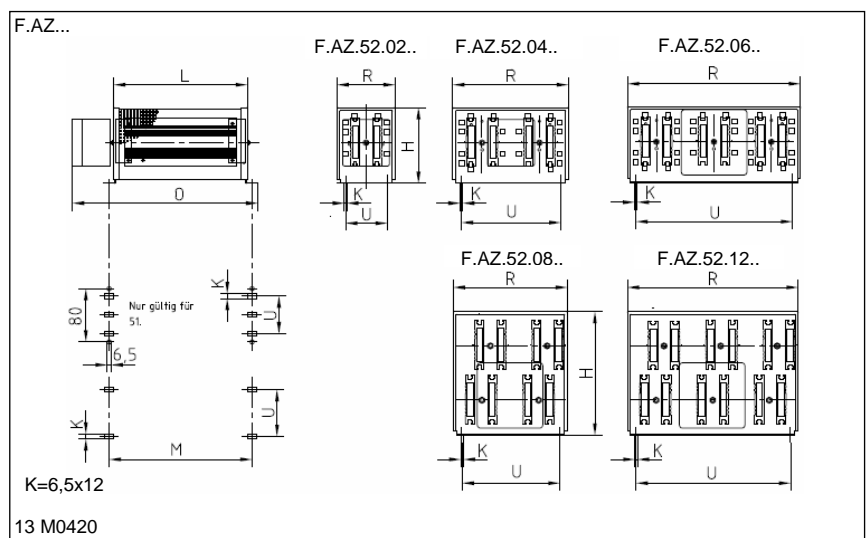



Type series WPAZQ..

10 – 40 kW, IP 54, water cooled,
with terminals and terminal box



WPAZQ91404



Wire wound flat type resistors in protection degree IP 54 in aluminium enclosure, combined with water cooler with integrated Cu-tubes. Electric wiring on terminals in attached terminal box. Cooling connection on two pipe connections 1 ¼ inch (DIN ISO 228).

Technologies

- very compact design
- high degree of protection IP 54
- very low excess of surface temperature (<40K)
- designed for water cooling by industrial water and almost any standard cooling liquid (dirt particles ≤ 1mm)
- max. working pressure 4 bar (test pressure 10 bar)
- max. drop of pressure 0,5 bar
- with temperature switch

Construction

Power resistor:
Electrical connection at terminals 16-95mm² (depending on design) in terminal box incl. cable gland up to M50.

Cooling:
The integrated Cu-tubes are for industrial water and almost any standard cooling liquids or oils – not for aggressive liquids, sea water or demineralized water.
Water connection at 1 ¼ inch thread for max. 3600 litre/hour. Maximum "In-Water" +30°C, maximum "Out-Water" +45°C.

Application

An important application is the use as internal load resistor or as brake resistor. The big advantage is the excellent transport of heat by the integrated cooling water connection.

Special design

- Mounting and connection material out of stainless steel
- with additional PT100 element
- integrated into switch cabinet

Electrical and mechanical data

type series	continuous dissipation in kW for cold "In-Water" of 20°C at 100%ED and a max. surface excess temperature of 30 K	necessary flow of cooling liquid in litre / h at a "Out-Water" temperature rise of 12K	production range Ω-value		dimensions in mm		approx. weight in kg
			from	up to	A	B	
WPAZQ90404	10	900	4,5	2,7 k	220	200	25
WPAZQ90604	15	1350	3,0	3,3 k	280	260	33
WPAZQ90804	20	1800	2,3	3,9 k	340	320	40
WPAZQ91004	25	2250	1,8	4,7 k	400	380	48
WPAZQ91204	30	2700	1,5	5,6 k	460	440	55
WPAZQ91404	35	3150	1,3	6,8 k	520	500	63
WPAZQ91604	40	3600	1,2	8,2 k	580	560	70

The given power rating values are valid for 100%CD (continuous dissipation). For short time operation you will find the values in the following table as a function of the duty cycle factor (DCF). Just multiply by the corresponding overload factor (OLF).

DCF	60%	40%	25%	15%	6%
OLF	1,2	1,6	2,2	3,1	5,5

These overload factors are valid for a total cycle time of maximum 120 s

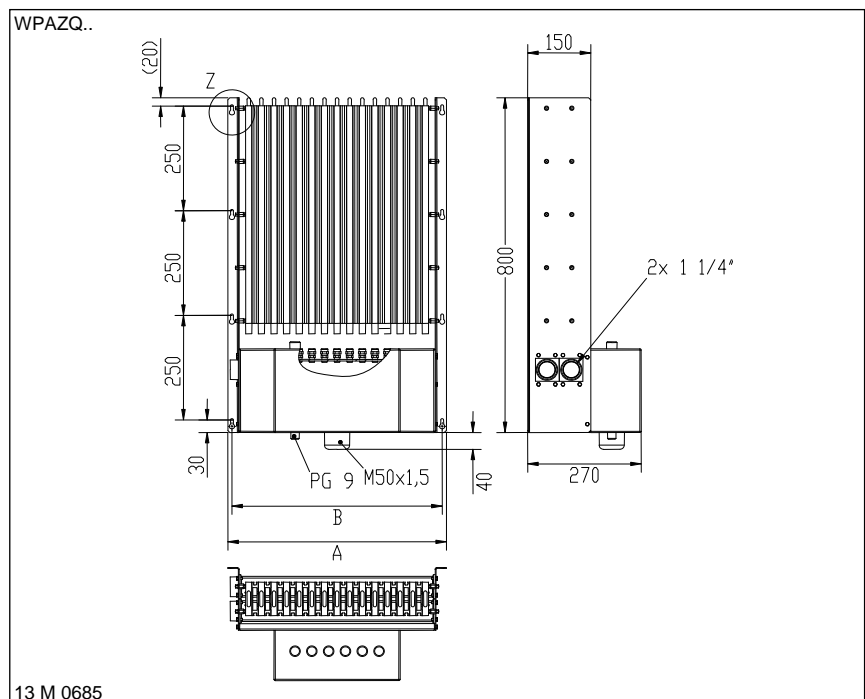

Accessories for type series G..D..x 80 and ..x 120
Type MWS3..

Mounting brackets sets – 2 types

We provide 2 different kinds of brackets as accessories, they consist of 2 brackets incl. mounting material in loose addition. A version with a mounted temperature switch is shown below (optional).

1.) Mounting variation A: set of 2 brackets type MWS301L
(incl. Mounting material; 2 screws M4x6 and M4x20)

A1: vertically mounted at the long side

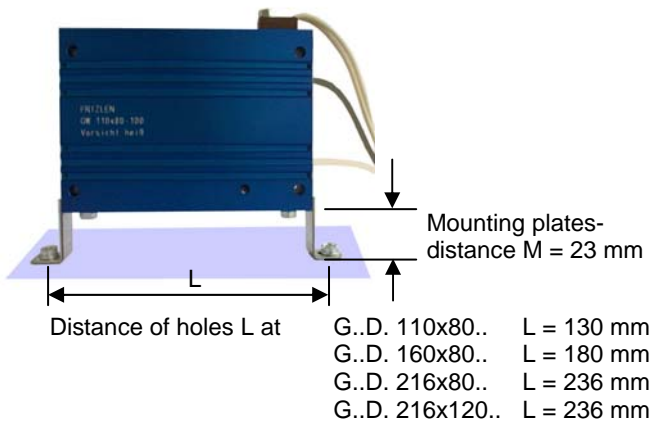

A2: hanging at the long side

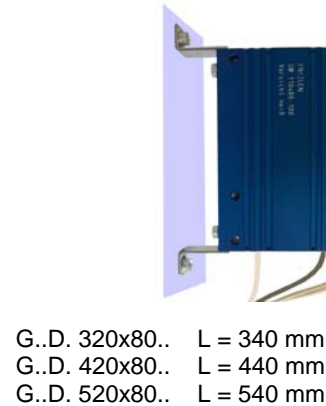

A3: horizontally mounted on surface (side view)

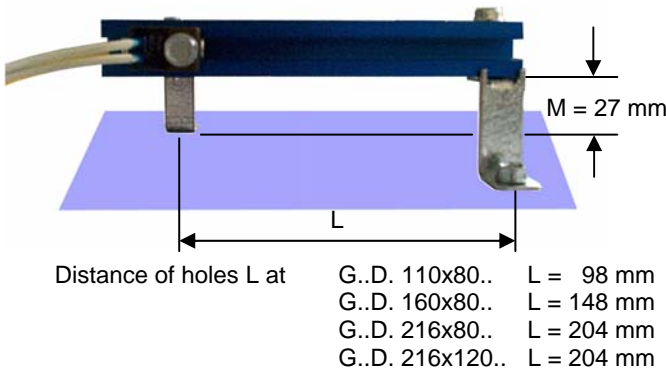

to A3:(plan view)

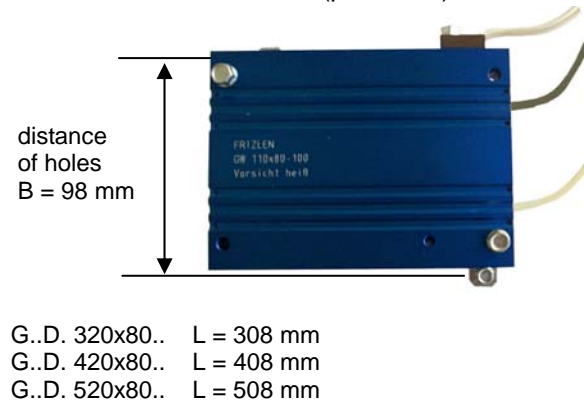

2.) Mounting variation B: set of 2 brackets type MWS302L
(incl. Mounting material; 2 screws M4x6)

B1: hanging at the short side

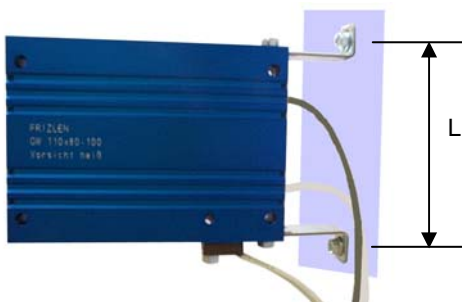

Distance of holes L for

G..D. 110x80.. to G..D. 216x80..	L = 98 mm
G..D. 216x120..	L = 138 mm

B2: vertically mounted at the short side

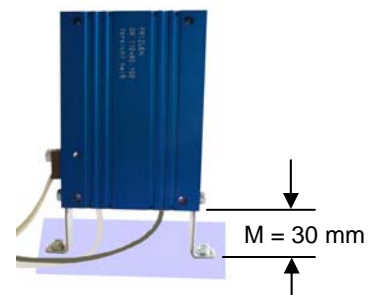

Accessories for type series K..D..x 91
Type MWS3..

Mounting brackets sets – 4 types

We provide 2 different kinds of brackets as accessories, they consist of 2 or 4 brackets incl. mounting material in loose addition. A version with a mounted temperature switch is shown below (optional).

1.) Mounting variation A:

set of 2 brackets Type MWS302L
(incl. mounting material; 2 screws M4x6)

A1: mounted on short side – hanging

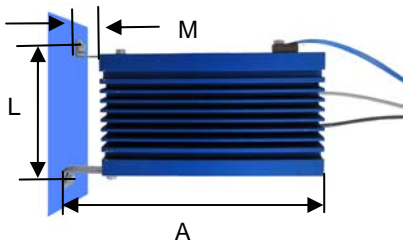

Mounting plate distance
M = 30 mm, distance of
holes L = 101 mm

A2: mounted on long side - hanging



Complete length A with resistor at K..D. 110x91.. A = 140 mm
K..D. 160x91.. A = 190 mm

K..D. 216x91.. A = 246 mm
K..D. 320x92.. A = 350 mm

2.) Mounting variation B:

set of 4 brackets Type MWS305L
(incl. mounting material; 4 screws M4x6)

B1: mounted on short side – hanging

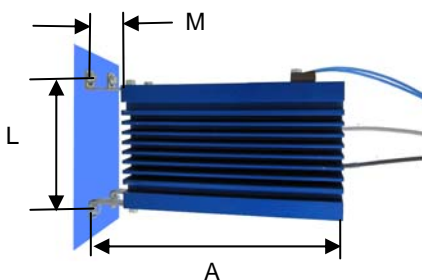

Mounting plate distance
M = 30 mm, distance of
holes L = 101 mm

B2: mounted on long side - hanging



Complete length A with resistor at K..D. 110x91.. A = 140 mm
K..D. 160x91.. A = 190 mm

K..D. 216x91.. A = 246 mm
K..D. 320x91.. A = 350 mm

3.) Mounting variation C:

set of 2 brackets Type MWS301L
(incl. mounting material; 2 screws M4x6 and 2 screws
M4x20)

C1: horizontally mounted on surface

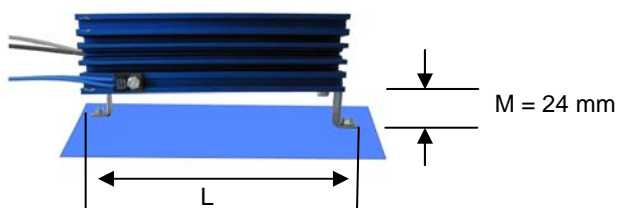

Distance of holes L for K..D. 110x91.. L = 128 mm
K..D. 160x91.. L = 178 mm

C2: vertically mounted - hanging



K..D. 216x91.. L = 234 mm
K..D. 320x91.. L = 338 mm

4.) Mounting variation D:

set of 4 brackets Type MWS306L
(incl. mounting material; 4 screws M4x6 and 4 screws M4x20)

D1: horizontally mounted on surface

D2: vertically mounted - hanging

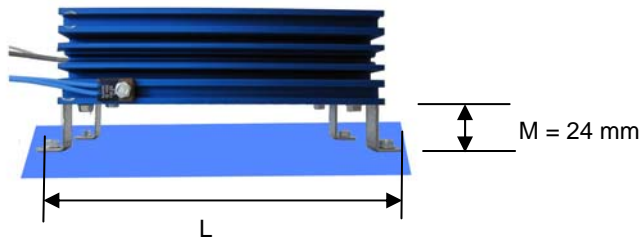

Distance of holes L for	K..D. 110x91..	L = 128 mm	K..D. 420x91..	L = 438 mm
	K..D. 160x91..	L = 178 mm	K..D. 520x91..	L = 538 mm
	K..D. 216x91..	L = 234 mm	K..D. 620x91..	L = 638 mm
	K..D. 320x91..	L = 338 mm	K..D. 720x91..	L = 738 mm

More details about the distance of holes please look at our dimension sheet 13 M 0559.

Further type series as examples of customized solutions

1. Resistor wired on terminals, also in compact multiple design for high short time energy absorption

Type series FBEMS..

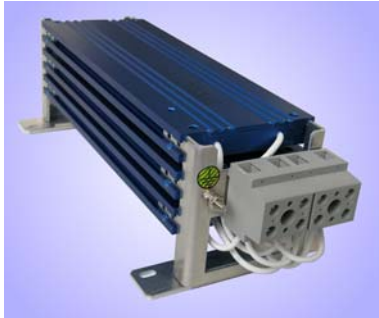

- construction very compact
- for horizontal mounting
- connection at terminals
- with ground connection
- degree of protection IP 20 (resistors IP 54)

Type series FBEM..



- construction very compact
- for vertical mounting
- connection at terminals
- with ground connection
- degree of protection IP 20 (resistors IP 54)

2. In multiple design for higher continuous dissipation

Type series GZDWM..



- mica flat resistor elements
- connection on terminals
- with cover
- with ground connection
- built-up with elements which have UL Recognition

Type series FFAE..



- flat type construction
- mounting on switch cabinet
- with grounded and screened wiring
- degree of protection IP 21 (resistors IP 54)

3. Special design for mounting beyond and beside servo- and frequency converter

Type series GUXD..



- connection by wires
- for mounting beyond and beside converters
- scalable design
- degree of protection IP 40

Type series GXWD..



- connection by wires
- for mounting beyond and beside converters
- optionally with ground and screen connection
- degree of protection IP 54



Type series GXWD..



- construction form very compact
- for vertically mounting
- connection by wires
- with ground connection
- degree of protection IP 54

Type series GXWD..



- construction form very compact
- customer integration direct at the motor
- connection by wires
- with ground connection
- degree of protection IP 54

4. Version with water-cooling and forced ventilation

Type series WPAD..



- water cooling
- lower temperature at surface
- connection direct at cooling system
- connection by wires
- degree of protection IP 54/67

Type series FDVEQ..



- forced ventilation
- flat resistor with UL-Recognition
- mounting in the switch cabinet
- with grounded and screened wiring
- degree of protection IP 20 (resistors IP 54)