

This document details the functionality of the following device and firmware variants:

- **Single-axis system** SO8x.xxx0.xxxx.xxxx.x / from firmware version V3.25-00
- **Multi-axis system** SO8x.xxx1.xxx.xxx.x / from firmware version V3.25-00
- **Junior** SO2x.xxx0.xxxx.xxxx.x / from firmware version V1.30-00

NOTE:



The content of this document corresponds to the online help for the ServoOne device family. It may contain minimal layout errors. The structure of the document is topic-oriented, and does not conform to the conventional book form.



Subject to technical change without notice.

The content of this Application Manual was compiled with the greatest care and attention, and based on the latest information available to us. We should nevertheless point out that this document cannot always be updated in line with ongoing technical developments in our products. Information and specifications may be subject to change at any time.

www.lt-i.com

Available documents at a glance

Document	Contents	Description
Operation Manual	Mechanical installation, Electrical installation, Safety, Specification	Hardware
Online device help (also as PDF)	Basic software description	Accessible in DriveManager 5
Online program help (also as PDF)	DriveManager 5 Description	Accessible in DriveManager 5
CANopen/EtherCAT User Manual	Description of CANopen/ EtherCAT field bus system	Hardware and software of field bus version
SERCOS User Manual	Description of SERCOS II field bus system	Hardware and software of field bus version
PROFIBUS-DPV User Manual	Description and parameter-setting of the ServoOne on the Profibus-DPV field bus system	Hardware and software of field bus version

Tabelle 0.0.1 Overview of documents

How do I read the documentation?

First be sure to read the Operation Manual, so as to install the device correctly. The layout of the sections of this Application Manual and the order of subject areas in the DriveManager follow the chronological sequence of an initial commissioning procedure. For basic configuration and operation of the motor you should follow the descriptions in the sections of this Application Manual. If you intend to utilize further internal functions of the drive, such as digital or analog I/Os, you should read the corresponding sections in this documentation. Here you will also find information concerning errors and warnings. If you use a field bus option board to control a controller, please use the relevant separate bus documentation.



ATTENTION:

Disregarding the safety instructions during installation may pose a danger to life for operating personnel and result in destruction of the output system.

Pictograms

To provide clear guidance, this Application Manual uses pictograms. Their meanings are set out in the following table. The pictograms always have the same meanings, even

where they are placed without text, such as next to a connection diagram.





Pictograms	Meaning
	NOTE: Useful information
	ATTENTION: Misoperation may result in damage to the drive or malfunctions.
	DANGER from electrical tension! Improper behaviour may endanger human life.
	DANGER from rotating parts: The drive may execute uncontrolled movements!

Tabelle 0.0.2 Meanings of pictograms

Legal notice

- LTI DRIVES GmbH provides the information and subject area listings contained in the Online Help as a service. LTI DRIVES GmbH gives no

guarantee that the information provided will achieve the desired results in your specific application environment.

- The decision as to whether to use the information provided – and if so, in what form – is entirely yours.
- The specialist personnel must ensure that the application or usage of the products described conforms to the technical specifications set out in the Installation Guide and the Operation Manual, as well complying with all safety requirements, including applicable laws, rules, regulations and standards.
- The Help was compiled with due diligence. However, the products described are continually being developed and improved. Consequently, the Help may not always be fully verified as conforming to the functionality, standards or other features specified.
- The statements made in this document do not embody a guarantee under the terms of Article 443 of the German Civil Code (BGB) or a specification of contractually required usage under the terms of Article 434 paragraph 1, clause 1, no. 1 BGB.
- If the Help contains any factual or typographical errors, we reserve the right to make changes at any time and without prior notice.
- The content of this Help is provided merely for information purposes. It may be changed without prior notice at any time, and in no way imposes any obligation upon LTI DRIVES GmbH.
- The information, illustrations and descriptions contained in this document cannot be used as justifiable grounds for modification of already delivered products.

Copyright

- copy; The Help is protected by copyright. It must not be disclosed or distributed, or used by third parties, in whole or in part, without the written consent of LTI DRIVES GmbH.

Table of contents

1	Initial commissioning	13
1.1	Initial commissioning – Rotary system	14

1.1.1	Commissioning wizard	14
1.1.2	Hardware requirements	14
1.1.3	Prompt to perform initial commissioning	14
1.2	Initial commissioning – Linear system	17
1.2.1	Commissioning wizard	17
1.2.2	Hardware requirements	17
1.2.3	Prompt to perform initial commissioning	17
1.3	Automatic tests	20
1.3.1	Follow the safety instructions	20
2	Power stage	22
2.1	Power stage setting	23
2.1.1	Switching frequency and voltage ratios	23
2.2	Power failure bridging	24
2.2.1	Power failure bridging for speed and position control	24
3	Motor	27
3.1	Motor, general	28
3.2	PS motor	29
3.2.1	Determining the motor data	29
3.3	PS linear motor	31

3.3.1	Determining the data of the linear motor.	31
3.4	AS motor	33
3.4.1	There are two methods of creating a motor data set for the asynchronous motor.	33
3.5	Motor identification	34
3.5.1	Motor identification wizard:	34
3.5.2	Motor identification PS motor	34
3.5.3	Motor identification AS motor	34
3.6	PSM characteristic	35
3.6.1	PSM characteristic setting	35
3.7	ASM characteristic	37
3.7.1	ASM characteristic setting	37
3.8	Motor protection	38
3.8.1	Temperature sensors	38
4	Encoder	42
4.2	Channel 2 Resolver X6	43
4.2.1	Evaluation of a resolver on channel 2	43
4.3	X6 Pin assignment	44
4.4	Track signal correction (GPOC)	45
4.4.1	Variants for track signal correction	45
4.5	Phase shift of resolver signals	46

4.6	Channel 1 Interface X7	46
4.6.1	Channel 1: Evaluation of high-resolution encoders	46
4.7	X7 Pin assignment	48
4.8	Track signal correction (GPOC) X7	50
4.8.1	Variants for track signal correction	50
4.9	Cyclic evaluation of digital encoders	51
4.10	Channel 3 X8	52
4.10.1	Valid versions	52
4.11	Evaluatable encoder types	53
4.12	Pin assignment X8	55
4.13	Pin assignment X8	55
4.14	Track signal correction (GPOC) X8	56
4.14.1	Variants for track signal correction	56
4.15	Technical data	57
4.16	Zero pulse test	58
4.17	Features of the SSI encoder	59
4.18	Pin assignment for SSI encoder simulation	60
4.19	Parameterization of SSI encoder simulation	60
4.20	Polarity and phase	61
4.21	Scan cycle SSI information	62
4.21.1	Synchronization	62
4.22	Features of the TTL module	63
4.22.1	Operation modes of the TTL module	63

4.23	Pin assignment of TTL encoder	64
4.24	Parameterization of the TTL encoder	65
4.24.1	Interface configuration of encoder for loop control	65
4.24.2	Configuration of TTL encoder simulation and repeater mode	66
4.25	Parameterization of the TTL encoder channel	68
4.26	TTL encoder zero pulse test	70
4.27	Technical data	70
4.28	Pin assignment of TTL with commutation signals	71
4.29	Parameterization of TTL encoder with commutation signals	73
4.29.1	Interface configuration of encoder for closed-loop control	73
4.30	Parameterization of TTL encoder channel with commutation signals	73
4.31	Zero pulse test	75
4.32	Redundant encoder	76
4.32.1	Monitoring the position difference	76
4.33	Axis correction	76
4.33.1	Deviation of actual position value	76
4.33.2	Determining the direction of movement	78
4.34	Encoder gearing	79
4.35	Multi-turn encoder as single-turn encoder	80
4.36	Increment-coded reference marks	80
4.37	Encoder signal oversampling	81

4.38	Overflow in multi-turn range	82
4.38.1	Overflow shift in multi-turn range:	82
4.39	Zero pulse test	83
5	Closed-loop control	85
5.1	Control basic setting	86
5.2	Motor control setup	87
5.2.1	Motor control basic setting	88
5.2.2	Adaptation of mass inertia	88
5.2.3	Adaptation to the rigidity of the drive train	89
5.3	Determining mass inertia	89
5.4	Current/torque controller settings	90
5.4.1	Current controller optimization	90
5.5	Schematic of expanded torque control	92
5.6	Adaptation of torque control	93
5.6.1	Saturation characteristic	93
5.7	Observer	94
5.7.1	Constant dynamic based on adaptation	94
5.8	Overmodulation	95
5.8.1	Limitation of voltage components	95
5.8.2	Hexagon modulation	95
5.9	Torque control with defined bandwidth	96

5.10	Detent torque compensation	97
5.11	Test signal generator (TG)	100
5.11.1	Optimization of control loops with the TG	100
5.11.2	PRBS signal	100
5.12	Optimizing the speed controller	104
5.13	Analysis of speed control	105
5.14	Digital filters	107
5.14.1	Setting of filter combinations	107
5.15	Advanced speed control (observer)	110
5.16	Reduktion der Geschwindigkeitsverstärkung	110
5.16.1	Reduktion bei kleinen Geschwindigkeiten	110
5.17	Sensorless quick-stop	111
5.18	Position controller setup	112
5.18.1	Position controller pre-control	113
5.19	Friction torque compensation	114
5.20	ASM field-weakening	116
5.21	Field-weakening of ASM voltage controller	117
5.22	Synchronous machine field-weakening	118
5.23	SM voltage controller field-weakening	121
5.24	Autocommutation for synchronous machines	122
5.24.1	IENCC(1) method	122
5.24.2	IECON(4) method	122

5.24.3	LHMES(2) method	123	6.11	Indexing table function direction of rotation setting	140
5.25	V/f mode	125	6.11.1	"Direction of rotation" setting	140
5.26	Function of process controller	125	6.12	Indexing table function path-optimized	141
5.26.1	Features	125	6.12.1	Path-optimized movement	141
5.26.2	Rate limiter	127	6.13	Indexing table function "Infinite driving job"	142
6	Motion profile	130	6.14	Indexing table function "Relative driving job"	142
6.1	Motion profile setting	131	6.15	Motion profile basic settings	142
6.2	Scaling / Units	132	6.15.1	Motion profile basic setting selection dialog box	142
6.2.1	Scaling wizard	132	6.16	Stop ramps	144
6.3	Weighting via the SERCOS profile	133	6.17	Homing	148
6.4	Force/torque weighting	134	6.17.1	Homing dialog box	148
6.4.1	Schematic of force/torque weighting	134	6.18	Homing method (-12)	149
6.5	Acceleration weighting	134	6.18.1	Method (-12)	149
6.5.1	Schematic of weighting method	134	6.19	Homing methods (-10) and (-11)	150
6.6	Speed weighting	135	6.19.1	Method (-10)	150
6.6.1	Schematic of weighting method	135	6.19.2	Method (-11)	151
6.7	Weighting of position data	136	6.20	Homing methods (-8) and (-9)	151
6.7.1	Schematic of position data weighting	136	6.20.1	Method (-8)	151
6.8	Modulo weighting	137	6.20.2	Method (-9)	152
6.9	User-defined scaling	137	6.21	Homing methods (-7) to (0)	152
6.10	Indexing table function setting "as linear"	139	6.21.1	Homing method for increment-coded encoders	152
			6.21.2	Method (-5) Absolute encoder	152
			6.21.3	Methods (-4) and (-3) are not defined	152

6.21.4	Method (-2) No homing	152
6.21.5	Method (-1) Actual position = 0	152
6.22	Homing methods 1 and 2: Limit switch and zero pulse	153
6.22.1	Method 1: Negative limit switch and zero pulse	153
6.22.2	Method 2: Positive limit switch and zero pulse	153
6.23	Homing methods 3 and 4: Positive reference cam and zero pulse	153
6.23.1	Method 3: Start movement in direction of positive (right) hardware limit switch	153
6.23.2	Method 4: Start movement in direction of negative (left) hardware limit switch	154
6.24	Homing methods 5 and 6: Negative reference cam and zero pulse	155
6.24.1	Method 5: Start movement in direction of positive (right) hardware limit switch with zero pulse	155
6.24.2	Method 5: Start movement in direction of negative (left) hardware limit switch with zero pulse	155
6.25	Homing methods 7 to 10:	155
6.25.1	Method 7: Reference cam, zero pulse and positive limit switch	155
6.25.2	Method 8:	156
6.25.3	Method 9:	157
6.25.4	Method 10:	157
6.26	Homing methods 11-14: Reference cam, zero pulse and negative limit switch	157

6.26.1	Method 11	157
6.26.2	Method 12	158
6.26.3	Method 13	158
6.26.4	Method 14	159
6.27	Homing methods 15 and 16	159
6.28	Homing methods 17-30: Reference cam	159
6.28.1	Method 17-30	159
6.29	Homing methods 31 and 32	160
6.30	Homing methods 33 and 34: With zero pulse	160
6.30.1	Method 33: Direction left:	160
6.30.2	Method 34: Direction right:	161
6.31	Homing method 35	161
6.31.1	Method 35	161
6.32	Jog mode	161
6.33	Electronic gearing settings	163
6.33.1	Electronic gearing / Synchronized movement	163
6.34	Master configuration	164
6.34.1	Specifying the master encoder:	164
6.35	Engagement and disengagement	166
6.36	Anti-reverse mode	168
6.37	Synchronization mode	169
6.38	Status and control word	171

6.38.1	Control word for electronic gearing	171
6.38.2	Status word for electronic gearing	172
6.39	Virtual Master	172
6.40	Cam plate	173
6.41	Reference table	173
6.41.1	Reference table setting	173
6.42	Analog channel	176
6.42.1	Settings	176
6.42.2	Position reference input via analog channel	178
6.43	State machine	179
6.43.1	State machine according to CiA402	179
6.44	Touchprobe	180
6.44.1	Configuration of touchprobe functionality	180
6.45	Speed control in PG mode	182
6.45.1	Profile Generator mode (PG mode)	182
6.46	Speed control in IP mode	183
6.46.1	Preparing the speed reference	183
6.47	Position control in PG mode	184
6.47.1	Profile Generator (PG) mode	184
6.47.2	Motion profile / Basic settings	184
6.48	Position control in IP mode	185
6.48.1	Interpolation (IP) mode	185
6.49	Jerk limitation and speed offset	185

6.49.1	Jerk limitation (Profile mode)	185
6.49.2	Speed offset (limitation)	185
6.50	Interpolation types	187
6.50.1	General definition of interpolation	187

7 Inputs/outputs190

7.1	Selecting inputs and outputs	191
7.2	Control location selector	191
7.3	Function selector - digital inputs	192
7.3.1	Function selector of the digital inputs	192
7.4	Hardware enable	194
7.4.1	Hardware enable or Autostart	195
7.5	Power-up sequence	195
7.6	Digital output function selectors	196
7.7	Reference reached REF(6)	199
7.7.1	Threshold definition	199
7.8	Reference limitation LIMIT (14)	200
7.8.1	Torque control	200
7.8.2	Speed control	200
7.8.3	Positioning	200
7.8.4	Infinite positioning/speed mode:	200
7.9	Switching with motor contactor	200

7.10	Analog input function selector	201
7.11	Interpolated mode (IP) and Profile Generator mode (PG)	202
7.12	Wire break monitoring	202
7.12.1	Wire break detection threshold setting	202
7.13	Analog input scaling	203
7.13.1	Analog input scaling function	203
7.14	Analog outputs	204
7.15	Motor brake output	205
7.15.1	Using a motor brake	205
7.16	Virtual inputs	208

8 Limits and thresholds 209

8.1	Limit value settings	210
8.1.1	Torque/speed/position limitation	210
8.1.2	Torque limitation	210
8.1.3	Speed limitation	211
8.1.4	Position limitation	212
8.2	Limitation by software limit switches	213
8.2.1	Software limit switch	213
8.3	Power failure reaction	213
8.3.1	Response to power failure	213

9 Alarm and warning 215

9.1	Error display	216
9.1.1	Meaning of error display	216
9.2	Error list	216
9.3	Error reactions	232
9.3.1	Assignment of error reactions	232
9.4	Warning thresholds	233
9.4.1	Defining thresholds	233
9.5	Warning status window	235
9.5.1	Warnings	235

10 Field buses 236

10.1	Profibus	237
10.1.1	Short description of PROFIBUS DP interface	237
10.2	PROFINET	237
10.3	CANopen, EtherCAT	237
10.4	SERCOS	238
10.4.1	Features	238

11 Technology option X8 240

11.1 Selection of modules241

12 Index 242

1 Initial commissioning

Information	
Navigation	Project tree: < Device setup < Initial commissioning
Pictograms	
Contents	<ul style="list-style-type: none">• Initial commissioning of rotary system.htm• Initial commissioning of linear system.htm• Automatic tests.htm

Tabelle 1.0.1 Initial commissioning subject area

1.1 Initial commissioning – Rotary system

1.1.1 Commissioning wizard

The wizard is used for targeted navigation through the subject areas relevant to initial commissioning. Setting the parameters correctly enables controlled movement of the drive by way of the manual mode window. For highly dynamic drive systems further settings must be made. If DriveManager 5 is opened with no project, a prompt appears asking if you want to carry out initial commissioning.

1.1.2 Hardware requirements

- Correct installation and wiring
As instructed in the Operation Manual
- Voltage supply:
Mains voltage
24 V control voltage
- Hardware enable:
Safe Standstill: **ISDSH**
Enable Power: **ENPO**

1.1.3 Prompt to perform initial commissioning

If this pop-up does not appear automatically, but you want to carry out commissioning using the wizard, you can also open the commissioning window again by clicking the pictogram or by way of the project tree. If the drive moves in an uncontrolled manner, or does not move at all, after initial commissioning, the parameter inputs must be checked.

Congratulations on choosing our produkt. Our aim is to help you configure your controller automatically.

If you select "Don't show this dialog again", you can perform the initial commissioning by clicking the initial commissioning item in the project tree.



Bild 1.1.1 Prompt to activate wizard

The wizard helps you with the initial configuration of the controller. Work through the individual subject areas in the specified sequence. Then the motor and controller will be set up.

The initial commissioning assistant makes it easy for you to configure your controller. Process the issues from top to bottom. Afterwards your controller is properly configured and the motor can be set in operation.



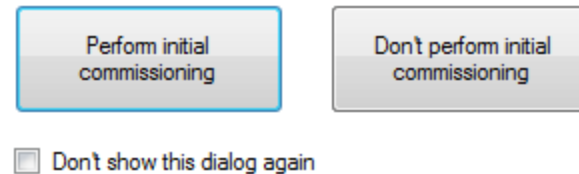















 1. Power stage	Select the switching frequency and the voltage of the power stage.
 2. Motor	Select the motor from the database or create a database manually.
 3. Encoder	Select the encoder from the database and determine the connection.
 4. Automatic tests	Execute the encoder offset detection, motor phase test and motor inertia detection.
 5. Control mode	Determine the control mode.
 6. Motion profile	Determine the normalization profile and select the parameter for motion profile.
 7. Limits	Determine the limits for position, torque, speed and power stage.
 8. Save / Finish	Save the settings. Go to the overview.

Bild 1.1.2 Commissioning wizard

Subject area	Action	Instruction
 Power stage	Set the switching frequency and the voltage supply of the power stage.	Adaptation of voltage supply to switching frequency
 Motor	Decision whether to use a synchronous motor (PSM) or an asynchronous motor (ASM).	Selection of motor
 Motor	Decision whether to use a rotary or linear motion system.	Selection of motor system
 Motor	Identification <ul style="list-style-type: none"> • Measurement of: <ul style="list-style-type: none"> Stator resistance Rotor resistance Leakage inductance • Current controller tuning • Calculation of nominal flux 	Identification of motor
 Motor	<ul style="list-style-type: none"> • Set the I²xt monitor • Select of temperature sensor • Characteristic setting 	Motor protection
 Encoder	<ul style="list-style-type: none"> • Encoder selection • Channel selection 	Encoder setting
 Automatic test	<ul style="list-style-type: none"> • Motor phase test • Determine encoder offset • Determine mass inertia 	Automatic tests
 Manual mode	Open manual mode window <ul style="list-style-type: none"> • Control mode VFC (open 	Motor test in manual mode without intervention of a higher-level PLC

Subject area	Action	Instruction
	<ul style="list-style-type: none"> loop) Move motor at low speed Check direction 	
	<ul style="list-style-type: none"> Optimize current controller (test signal generator) When there is a motor data set the current of the test signal generator is set automatically. Optimize speed controller Determine mass inertia [J] (basic settings) Speed filter setting: P 0351 CON_SCALC_TF = (0,6 ms) Recommendation: SinCos encoder 0.2 ms - 0.6 ms Resolver 1 ms - 2 ms Adapt control parameters to mechanism (adjust rigidity). 	<p>Controller setting</p> <ul style="list-style-type: none"> Current controller Speed controller Position controller
	<ul style="list-style-type: none"> Units Reference source Reference processing Stop ramps Homing method 	Motion profile setting
	<p>Limits:</p> <ul style="list-style-type: none"> Torque Speed 	Define limits

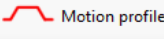

Subject area	Action	Instruction
	<ul style="list-style-type: none"> Position 	
	<p>Scaling, IOs, field buses:</p> <ul style="list-style-type: none"> CANopen PROFIBUS SERCOS 	<p>Set marginal conditions.</p> <p>For more information refer to the user manuals for the individual bus systems.</p>
	<p>Saving the settings:</p> <p>Create a commissioning file</p>	<p>Saving: For more information on data handling refer to the Online Help in DriveManager 5</p>

Tabelle 1.1.3 Commissioning wizard instructions

1.2 Initial commissioning – Linear system

1.2.1 Commissioning wizard

The wizard is used for targeted navigation through the subject areas relevant to initial commissioning. Setting the parameters correctly enables subsequent controlled movement of the drive by way of the manual mode window. For exact adaptation of the drive system to an application, further settings need to be made. If DriveManager 5 is opened with no project, a prompt appears asking if you want to carry out initial commissioning.

1.2.2 Hardware requirements

- Correct installation and wiring
As instructed in the Operation Manual
- Voltage supply:
Mains voltage
24 V control voltage
- Hardware enable:
Safe Standstill: **ISDSH**
Enable Power: **ENPO**

1.2.3 Prompt to perform initial commissioning

If this pop-up does not appear automatically, but you want to carry out commissioning using the wizard, you can also open the commissioning window again by clicking the pictogram or by way of the project tree. If the drive moves in an uncontrolled manner, or does not move at all, after initial commissioning, the parameter inputs must be checked.

Congratulations on choosing our produkt. Our aim is to help you configure your controller automatically.

If you select "Don't show this dialog again", you can perform the initial commissioning by clicking the initial commissioning item in the project tree.



Bild 1.2.1 Prompt to activate wizard

Commissioning with wizard

The wizard helps you with the initial configuration of the controller. Work through the individual subject areas in the specified sequence. Then the motor and controller will be set up.

The initial commissioning assistant makes it easy for you to configure your controller. Process the issues from top to bottom. Afterwards your controller is properly configured and the motor can be set in operation.

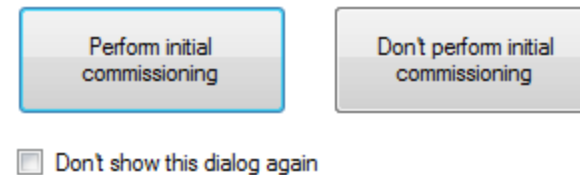















 1. Power stage	Select the switching frequency and the voltage of the power stage.
 2. Motor	Select the motor from the database or create a database manually.
 3. Encoder	Select the encoder from the database and determine the connection.
 4. Automatic tests	Execute the encoder offset detection, motor phase test and motor inertia detection.
 5. Control mode	Determine the control mode.
 6. Motion profile	Determine the normalization profile and select the parameter for motion profile.
 7. Limits	Determine the limits for position, torque, speed and power stage.
 8. Save / Finish	Save the settings. Go to the overview.

Bild 1.2.2 Commissioning wizard dialog box

Subject area	Action	Instruction
 Power stage	Set the switching frequency and the voltage supply of the power stage.	Adaptation of voltage supply to switching frequency
 Motor	Parameter P 0450 MOT_Type is automatically set to PSM if parameter P 0490 MOT_IsLinMot = LIN(1) .	Selection of motor
 Motor	Selection for a linear motion system with P 0490 = LIN(1)	Selection of motor system
 Motor	Data set calculation: Fill out "Calculation of control setup for linear synchronous motors" dialog box and start calculation	Calculation of motor data set
 Motor	<ul style="list-style-type: none"> • Set the I²xt monitor • Select of temperature sensor • Characteristic setting 	Motor protection
 Encoder	<ul style="list-style-type: none"> • Encoder selection • Channel selection 	Encoder setting

Subject area	Action	Instruction
 Automatic test	<ul style="list-style-type: none"> • Motor phase test • Determine encoder offset • Determine mass inertia 	Automatic tests
 Manual mode	<p>Open manual mode window</p> <ul style="list-style-type: none"> • Control mode VFC (open loop) • Move motor at low speed • Check direction 	Motor test in manual mode without intervention of a higher-level PLC
 Control	<p>Optimize current controller (test signal generator). When there is a motor data set the current of the test signal generator is set automatically.</p> <p>Optimize speed controller</p> <p>Determine mass inertia [J] (basic settings)</p> <p>Speed filter setting: P 0351 CON_SCALC_TF = (0,6 ms) Recommendation: SinCos encoder 0.2 ms - 0.6 ms Resolver 1 ms - 2 ms Adapt control parameters to mechanism (adjust rigidity).</p>	<p>Controller setting</p> <ul style="list-style-type: none"> • Current controller • Speed controller • Position controller
 Motion profile	Setting:	Motion profile setting

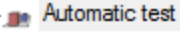
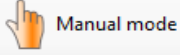

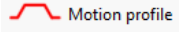
Subject area	Action	Instruction
	<ul style="list-style-type: none"> • Units • Reference source • Reference processing • Stop ramps • Homing method 	
 Limits	<p>Limits:</p> <ul style="list-style-type: none"> • Torque • Speed • Position 	Define limits
 Fieldbus	<p>Scaling, IOs, field buses:</p> <ul style="list-style-type: none"> • CANopen • PROFIBUS • SERCOS 	<p>Set marginal conditions.</p> <p>For more information refer to the user manuals for the individual bus systems.</p>
	<p>Saving the settings:</p> <p>Create a commissioning file</p>	<p>Saving: For more information on data handling refer to the Online Help in DriveManager 5</p>

Tabella 1.2.3 Commissioning wizard instructions

1.3 Automatic tests

1.3.1 Follow the safety instructions

Read the safety notice and check the box to confirm it.



Bild 1.3.1 Safety notice for conducting automatic tests

Dialog box for automatic tests



Bild 1.3.2 Dialog box for automatic tests

Motor phase checking

A motor phase check has been implemented which permits monitoring of the motor wiring. It also checks whether the parameter setting of the pulses per revolution of the encoder and the number of pole pairs of the resolver match the number of pole pairs of the motor.

Project tree < Initial commissioning < Automatic tests

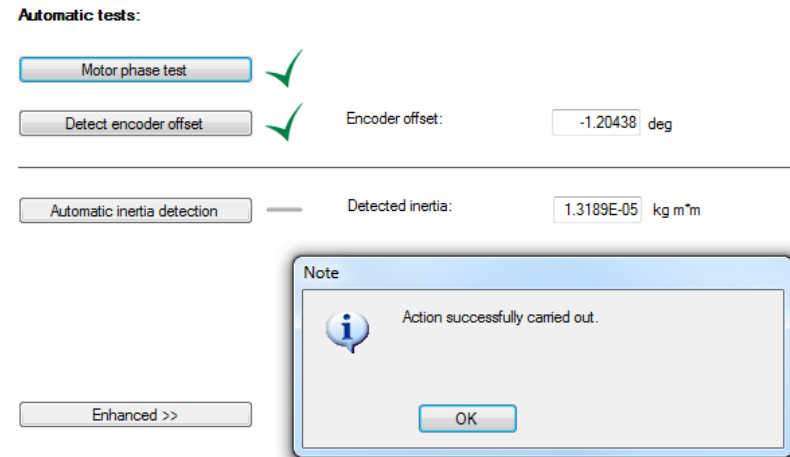
Determining the encoder offset

Once the safety notice window has been confirmed, the wizard is activated to determine the encoder offset. When it has been successfully determined, a green

tick (check-mark) is displayed.

Project tree < Initial commissioning < Automatic tests

Determining mass inertia

Once the safety notice window has been confirmed, the wizard is activated to determine the mass inertia. When it has been successfully determined, a green tick (check-mark) is displayed.

Project tree < Initial commissioning < Automatic tests

[Determining mass inertia.htm](#)

"Enhanced" button

When you click the "Enhanced" button you are provided by the wizard with support in setting up the current, torque, speed and position controllers. If further optimization is required, the controller buttons route you to more detailed dialog boxes.

2 Power stage

Information	
Navigation	Project tree < Device setup < Power stage
Pictograms	
Contents	<ul style="list-style-type: none"> • Power stage setting.htm • Power failure bridging.htm

Tabelle 2.0.1 Power stage subject area

2.1 Power stage setting

2.1.1 Switching frequency and voltage ratios

The power stages of the controller can be operated with different voltages and switching frequencies. The voltage and the switching frequency must be adapted to the conditions. The list boxes in the dialog box are used to adapt the power stage to the application conditions. For single-axis applications only the settings (0)-(5) are allowed. All other settings should be used for multi-axis systems. Not all switching frequencies can be used on higher-powered devices. An excessively high switching frequency setting in conjunction with high powers may result in a power reduction.

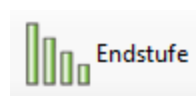
Switching frequency setting

The switching frequency is set via **P 0302 CON_SwitchFreq**. It is advisable initially to operate the drive controller with the default setting (8 kHz). Increasing the switching frequency can be useful to improve the control dynamism.

However, it may under some circumstances result in a temperature-related loss of power. Switching frequency noise decreases as the switching frequency rises (audible range < 12 kHz). For an overview of the currents dependent on the switching frequency refer to the Operation Manual.

The combination of voltage value and switching frequency describes a stored power stage data set.

Voltage ratio settings

The voltages are set according to the switching frequencies in parameter **P 0307 CON_VoltageSupply**.

Mains voltage: 1/3x230V AC(1) = 1/3 x 230 V mains

Note: Selected mains will be activated after restart of drive only.

Switching frequency: 8kHz(3) = 8 kHz switching frequency

Online derating of switching frequency: OFF(0) = Function disabled

Characteristics of power stage:

Rated current of powerstage	3 A
Undervoltage at	210 Vdc
Power stage enable from	250 Vdc
Overvoltage at	408 Vdc
Brake chopper switched on at	390 Vdc

Note: Update of characteristics only after drive-reset or motor control enable.

Bild 2.1.1 Power stage

Parameters

P. no.	Parameter name Setting	Description
P 0302	CON_SwitchFreq	Power stage switching frequency setting
	2 kHz - 16 kHz 2 kHz only for BG7	It is advisable to operate the drive controller with the default setting. Increasing the switching frequency can be useful to improve the control dynamism. Temperature-related

P. no.	Parameter name Setting	Description
		derating may occur. Switching frequency noise decreases as the switching frequency rises (audible range < 12 kHz).
P 0307	CON_ VoltageSupply	Adaptation to the voltage conditions
	1x 230 V(0)	Single-phase device
	3x 230 V(1)	Three-phase device
	3x 400 V(2)	Three-phase device
	3x 460 V(3)	Three-phase device
	3x480 V(4)	Three-phase device
	Safety low voltage 24-60 V(5)	
P 0752	MON_PWM_ SwitchFreqSelect_ Sel	Online switching frequency reduction
(0)	OFF	No function
(1)	AUTO (1)	Automatic switchover
(2)	MAN(2)	Automatic switch to manual switching frequency setting (P 0758)
P 0758	CON_SwitchFreq_ selMan	Manually adjustable switching frequency
(0)	2 khz	2 Khz

P. no.	Parameter name Setting	Description
(1)	4 khz	4 Khz

Table 2.1.2 Power stage parameters



ATTENTION:

The setting is only applied on the device after a power off/on cycle. If the power stage parameters are changed, the rated currents, overload values and brake chopper thresholds may also change. Any changes to parameters must be saved in the device.

2.2 Power failure bridging

2.2.1 Power failure bridging for speed and position control

There are a variety of setting options for power failure bridging in closed-loop controlled mode.

Setting: P 02949 SRLWR(1) and SRLOR(2)

Addition of **P 2944** (software shut-off limit) and

P 2942(1) = voltage reference value.

The resultant voltages must not be greater than the detection limit.

Setting: P 2940 = SRLWOR(3):

Addition of **P 2945** (brake chopper switch-on threshold) and **P 2942(1)** (voltage reference value).

The voltage must not fall below 95% of the brake chopper switch-on threshold. If the mains power is restored within this time, in speed control a restart is effected with the parameterized speed ramp from the profile generator. In position-controlled mode the speed is run down to zero with the preset quick-stop ramp.

If the mains power is not restored within the preset time, an error message is generated. The system reacts according to the error reaction (Fault 34 Reac_PowerFail).

Parameters

P. no.	Parameter name	Function
P2940	CON_PowerFail	Selector
(0)	Off(0)	No function
(1)	SRLWR(1)	Longest possible speed reduction with restart
(2)	SRLWOR(2)	Longest possible speed reduction without restart
(3)	SRLWOR(3)	Fastest possible speed reduction without restart.

P. no.	Parameter name	Function
P2941	CON_POWF_VCtrl	Voltage controller changeable online
(0)	Kr	Gain factor of PI voltage controller
(1)	Tn	Integral-action time of PI voltage controller
P2942	CON_POWF_VLim	Voltage limit in case of power failure
(0)	POWF_Von	Power failure detection limit
(1)	POWF_VRef	Voltage reference value
P2943	CON_POWF_RetTime	Setting of time window in which mains power can be restored
P2944	CON_POWF_UdcOff	Software shut-off limit for detection of DC link undervoltage
P2945	CON_POWF_UbcOn	Brake chopper switch-on threshold

Tabella 2.2.1 Mode selector for speed reduction

Power failure bridging

- **P 2940** Selection of power failure mode (1), (2) or (3)
- PI voltage controller setting:
 - **P 2941(0)** Gain
 - **P 2941(1)** Integral-action time
- **P 2943** For mode 1 the time within which the mains power may be restored to execute a restart is set.
- **P 2942(0)** Parameterize power failure detection limit
- **P 2942(1)** Parameterize voltage reference value. The power failure

detection limit is formed by adding together parameter **P2944** "Software shut-off limit for detection of DC link undervoltage" and the value **P 2942 (0)**. It must be $95\% < \text{DC link voltage}$.

3 Motor

Information	
Navigation	Project tree: < Device setup < Motor
Pictograms	 Geber
Contents	<ul style="list-style-type: none">• Motor general.htm• PS motor.htm• PS linear motor.htm• AS motor.htm• Motor identification.htm• Motor protection.htm

Tabelle 3.0.1 Motor subject area

3.1 Motor, general

Each motor can only be operated if its field model and the control parameters are correctly set. Using the standard motors and encoders from the motors catalog on the lt-i.com website, a system can be commissioned into operation very quickly and easily.

Third-party motors can also be used however. Since the field models of those motors are not known, the motor must be identified by type or calculated. The selection is made by means of the "Motor data and control settings" dialog box.

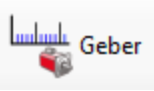
Motor data and control settings



Motor name

Manual control data setting

Motor type

Motor movement

Calculate control settings subject to motor data sheet

Calculate control settings subject to motor data identification

Further settings

Bild 3.1.1 Motor data and control settings

Loading a motor data set

- Open "Motor data and control settings" dialog box
- Select data set
- Enter encoder settings
- Save data

Commissioning of a third-party motor

In the case of third-party motors, basic suitability for operation with LTI DRIVES GmbH controllers must first be verified on the basis of the motor data and the data of any installed encoder. The values of the parameters for adaptation of the controller must be determined specifically for each motor by calculation or identification. The difference between the two methods is that when calculating a motor data set the impedances must be taken from the data sheet. In identification the impedances are measured automatically. Each motor can only be operated if its field model and the control parameters are correctly set.

You can obtain the data sets of all standard synchronous motors from the LTI website. On transfer of a standard motor data set the motor name, electrical data and motion mode are loaded. Preset parameters are overwritten. The motor data must then be saved in the device. The motor parameters specified by the manufacturer ensure that a motor can be subjected to load according to its operational characteristic, provided the corresponding power is supplied by the controller.



NOTE:

Each motor can only be operated if its field model and the control parameters are correctly set.

- Variant 1: Motor calculation
- Variant 2: [Motor identification.htm](#)

Vorgehensweise: Motor calculation

- Enter motor data
The motor data relevant to the calculation must be entered manually from the data sheet.
- Click the "calculation" button.
- If the moment of inertia of the motor **P 0461 Mot_J** is not known, a value roughly corresponding to the motor's moment of inertia must be applied.
- The calculation process be observed on the DriveManager 5 by choosing the View, Messages menu.
- Calculation of operating point:
P 0462 MOT_FLUXNom nominal flux,
- Calculation of: current, speed and position control parameters



ATTENTION:

All existing motor parameters are overwritten.

3.2 PS motor

3.2.1 Determining the motor data

There are two methods of creating a motor data set for the rotary synchronous motor.

Calculation of control settings for PS motor 

Motor name

Rating plate data

Rated voltage V Rated current A
 Rated speed rpm Rated frequency Hz

Rated frequency Hz **OR** Pole pairs

Rated torque Nm **OR** Rated power kW

Inertia

Motor inertia kg m²m Total inertia kg m²m

Motor impedances

Stator resistance Ohm Stator inductance mH

Bild 3.2.1 Calculation of PS motor

Calculated values

- Flux settings (including for torque constant)
- Control settings for current controller:
The current controller is dimensioned dependent on the switching frequency setting.
- Speed controller and position controller gain:
In this, a moderately rigid mechanism and a 1:1 moment of inertia adjustment from the load to the motor are to be assumed.
- V/F characteristic



ATTENTION:

All existing control parameters are overwritten.

Parameters

P. no.	Parameter name	Function
P 0490	MOT_IsLinMot	Selection for rotary or linear system
P 0450	MOT_Type -> PSM	Motor type (ASM, PSM)
P 0451	MOT_Name ¹⁾	Freely selectable motor name
P 0455	MOT_FNom ²⁾	Rated frequency of the motor
P 0456	MOT_VNom ²⁾	Rated voltage of the motor
P 0457	MOT_CNom ²⁾	Rated current of the motor
P 0458	MOT_SNom ²⁾	Rated speed
P 0459	MOT_PNom ¹⁾	Rated power
P 0460	MOT_TNom ²⁾	Nominal torque
P 0461	MOT_J ²⁾	Mass inertia of the motor
P 0463	MOT_PolePairs ²⁾	Number of pole pairs
P 0470	MOT_Rstat ²⁾	Stator resistance: The phase resistance is taken into account in the calculation.
P 0471	MOT_Lsig ²⁾	Stator inductance: The stator inductance is taken into account in the calculation.

P. no.	Parameter name	Function
P1530	SCD_SetMotor control	Start of calculation
<p>1) The parameters are only of informative nature, but should be set for a complete motor data set.</p> <p>2) The parameters are used for calculation of controller settings, and have a direct effect on the response of the servocontroller.</p>		

Tabelle 3.2.2 Parameters to determine the motor data

3.3 PS linear motor

3.3.1 Determining the data of the linear motor.

There are two methods of creating a motor data set for the linear synchronous motor.

- Variant 1: Motor calculation
- Variant 2: [Motor identification.htm](#)

Vorgehensweise: Calculation

- Enter motor data
The motor data relevant to the calculation must be entered from the data sheet.
- Click the "calculation" button.
- If the moment of inertia of the motor **P 0461 Mot_J** is not known, a value roughly corresponding to the motor's moment of inertia must be applied.
- The calculation process be observed on the DriveManager 5 by choosing the View, Messages menu.
- Calculation of operating point:
P 0462 MOT_FLUXNom nominal flux,
- Calculation of: current, speed and position control parameters

NOTE:



P 0490 MOT_ISLinRot=LIN(1) The parameter automatically sets the number of pole pairs for the motor to **P 0463 Mot_PolePairs = 1**.

As a result, a North to North pole pitch corresponds to one virtual revolution

(P 049 Mot_MagnetPitch)



ATTENTION:

All existing motor parameters are overwritten.

Calculation of control settings for linear PS motor

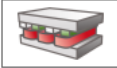

Motor name

Rating plate data

Rated voltage	<input type="text" value="200"/> V	Rated current	<input type="text" value="1.11"/> A
Maximum speed	<input type="text" value="2"/> m/s	Magnet pitch (NN)	<input type="text" value="20"/> mm
Rated force	<input type="text" value="1000"/> N		

Weight

Motor weight (coil)	<input type="text" value="10"/> kg	Total weight	<input type="text" value="10"/> kg	<input type="button" value="Info ..."/>
---------------------	------------------------------------	--------------	------------------------------------	---

Motor impedances

Stator resistance	<input type="text" value="8.7"/> Ohm	Stator inductance	<input type="text" value="17.05"/> mH	<input type="button" value="Info ..."/>
-------------------	--------------------------------------	-------------------	---------------------------------------	---

Encoder

Encoder period	<input type="text" value="20"/> um
----------------	------------------------------------

- Translation of the linear nominal quantities into virtual rotary nominal quantities
- Default values for autocommutation
- Encoder lines per virtual revolution
- Flux settings (including for torque constant)
- Control settings for PI current controller: The current controller is dimensioned dependent on the switching frequency setting.
- PI-speed controller and position controller amplification: In this, a moderately rigid mechanism and a 1:1 moment of inertia adjustment from the load to the motor are assumed.
- The default value for speed tracking error monitoring corresponds to 50% of the nominal speed.
- V/F characteristic

Bild 3.3.1 Calculation of controller setting for linear PS motors

Calculated values

3.4 AS motor

3.4.1 There are two methods of creating a motor data set for the asynchronous motor.

- Variant 1: Motor calculation
- Variant 2: [Motor identification.htm](#)

Calculation:

- Enter motor data
The motor data relevant to the calculation must be entered from the data sheet.
- Click the "calculation" button.
- If the moment of inertia of the motor **P 0461 Mot_J** is not known, a value roughly corresponding to the motor's moment of inertia must be applied.
- The calculation process be observed on the DriveManager 5 by choosing the View, Messages menu.
- Calculation of operating point:
Flux **P 0462 MOT_FluxNom**, **P 0340 CON_FM_Imag**.
- Calculation of: current, speed and position control parameters



ATTENTION

All existing motor parameters are overwritten.

Calculation of control settings for AS motor 

Motor name

Name plate data

Rated voltage V Rated current A
Rated speed rpm Rated frequency Hz

Rated frequency Hz **OR** Pole pairs

Rated torque Nm **OR** Rated power kW

Inertia

Motor inertia kg m²m Total inertia kg m²m

Motor impedances

Stator resistance Ohm Leakage inductance mH

Rotor resistance Ohm X / 100%

Bild 3.4.1 Calculation of AS motor

Calculated values

- Flux settings (including for torque constant)
- Control settings for current controller:
The current controller is dimensioned dependent on the switching frequency setting.
- Speed controller and position controller gain:
In this, a moderately rigid mechanism and a 1:1 moment of inertia adjustment from the load to the motor are to be assumed.
- V/F characteristic

3.5 Motor identification

3.5.1 Motor identification wizard:

When the motor data have been entered in the dialog box, identification is started by clicking the "Start identification" button. A safety notice must be confirmed with a tick (check mark).

3.5.2 Motor identification PS motor

- Enter motor data
- Click "Identification" button
- Current controller tuning: The current controller is automatically optimized.

3.5.3 Motor identification AS motor

- Current controller tuning
- Measurement of: **P 0470 MOT_RST** stator resistance, **P 0476 MOT_Rrot** rotor resistance, **P 0471 MOT_LSig** leakage inductance
- Max. effective current **Idmax P 0474 MOT_LmagIdNom**
- Calculation of operating point: **P 0462 MOT_FLUXNom** nominal flux, **P 0340 CON_FM_Imag** magnetizing current
- Calculation of: current, speed and position control parameters
- Click the "Start calculation" button to determine the rotor resistance **P 0476 MOT_Rrot** and leakage inductance **P 0471 MOT_LSig**.
- Measurement of the saturation characteristic (table values of the stator inductance **P 0472_NMOT_LSigDiff**).
Measurements are taken up to four times rated current, provided the

power stage current permits it at standstill. If it does not, the measurement is taken with a correspondingly lower current.

- **P 0340 CON_FM_Imag** magnetizing current

3.6 PSM characteristic

3.6.1 PSM characteristic setting

Characteristic setting for a permanently excited synchronous motor (PSM). A synchronous motor by design has lower loss than an ASM (because permanent magnets replace the magnetizing current). It is normally not internally cooled, but discharges its heat loss by internal convection. For that reason it has a different characteristic to an asynchronous motor. It is necessary to adapt the I^2xt characteristic because the factory setting mostly does not exactly map the present motor. The difference between factory setting and the characteristic configured above is shown in the following illustration.

If the I^2xt type is set to "THERM(1) = Thermal time constant dependent", all settings apart from the thermal time constant are disabled.

Calculate control settings subject to motor data identification



Motor name

Name plate data

Rated voltage	<input type="text" value="200"/> V	Rated current	<input type="text" value="1.11"/> A	
Rated speed	<input type="text" value="4500"/> rpm	Rated frequency	<input type="text" value="225"/> Hz	
<input checked="" type="radio"/> Rated torque	<input type="text" value="0.45"/> Nm	OR	<input type="radio"/> Rated power	<input type="text" value="0.21195"/> kW

Inertia

Motor inertia kg m²

Hold brake applied

Bild 3.5.1 "Motor identification" dialog box



Bild 3.6.1 PSM characteristic

Frequency/current values

Frequency	Motor current
$f_0 = 0 \text{ Hz}$	$I_0 = 133.33 \%$ of IN
$f_1 = 250 \text{ Hz}$	$I_1 = 100\%$ of IN
$f_N = 250 \text{ Hz}$	$I_N = 100\%$

Tabelle 3.6.2 PSM characteristic

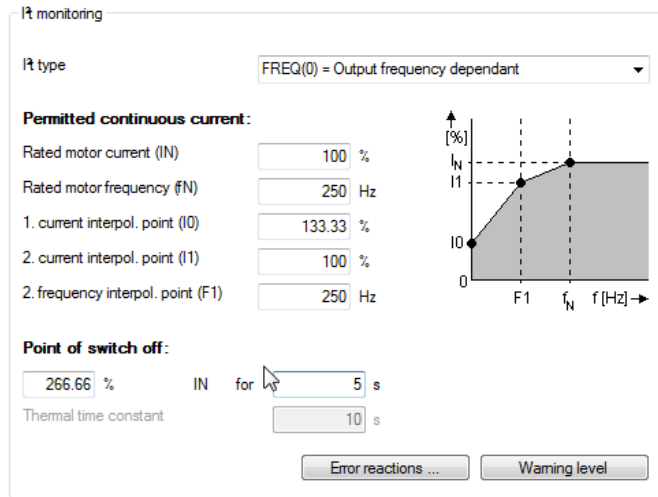
Typical setting for the permanently excited synchronous machine

If the integrator exceeds its limit value, the error E-09-01 is triggered. The current value of the integrator is indicated in parameter P 0701(0) Mon_ActValues.



Bild 3.6.3 PSM characteristic factory setting

Calculation of capacity utilization via exponential function with thermal time constant of motor:

$$y(t) = (1 - e^{-\frac{t}{t_{th}}}) * \left(\frac{I_{st}}{I_{nenn}}\right) * 100$$

Setting of I²t type:

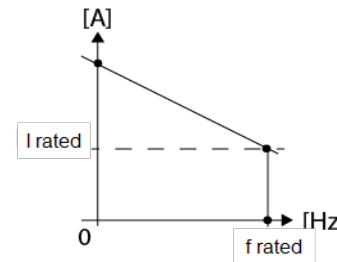
- **P 0735(0)** = LTI-specific evaluation $i(f)$
- **P 0735(1)** = Evaluation as per thermal time constant $i(T_{th})$
- Thermal time constant Parameter **P 0733(7)** T_{therm} in [s]
- The shut-off threshold is 110% (reduction in current noise)

↑ monitoring

I²t type FREQ(0) = Output frequency dependent

Permitted continuous current:

Rated motor current (I_N) 100 %

Rated motor frequency (f_N) 225 Hz

1. current interpol. point (I₀) 114 %

2. current interpol. point (I₁) 100 %

2. frequency interpol. point (F₁) 225 Hz

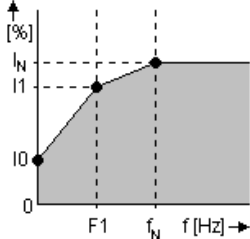

Point of switch off:

228 % I_N for 2 s

Thermal time constant 10 s

Error reactions ... Warning level

Bild 3.7.1 Motor protection I²xt

Frequency-current data

Frequency	Motor current
f ₀ = 0 Hz	I ₀ = 30% of I _N
f ₁ = 25 Hz	I ₁ = 80% of I _N
f _N = 50 Hz	I _N = 100%

Tabelle 3.7.2 Frequency-current data

Factory setting

3.7 ASM characteristic

3.7.1 ASM characteristic setting

The following diagram shows a typical characteristic setting for an internally cooled asynchronous machine. For third-party motors the motor manufacturer's specifications apply.

It is necessary to adapt the I²xt characteristic because the factory setting mostly does not exactly map the present motor. For servomotors, it is advisable to set a constant characteristic. The switch-off point defines the permissible current/time area up to switching off **150 % x I_N for 120 s**. If the I²xt type is set to "THERM (1) = Thermal time constant dependent", all settings apart from the thermal time constant are disabled.



Bild 3.7.3 ASM characteristic factory setting



NOTE:

The limits are specified in the servocontroller as percentages of the rated quantities (e.g. current, torque, speed,...) of the motor. The defaults relate to 100 % of the rated quantities.

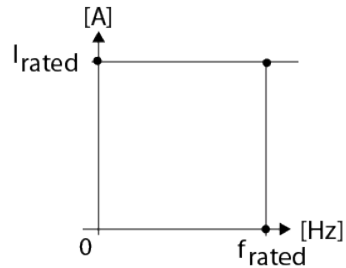
Calculation of capacity utilization via exponential function with thermal time constant of motor:

$$y(t) = (1 - e^{-\frac{t}{\tau_{th}}}) * \left(\frac{I_{ist}}{I_{nenn}}\right) * 100$$

Setting of I²t type:

- **P 0735(0)** = LTi-specific evaluation i(f)
- **P 0735(1)** = Evaluation as per thermal time constant i(Tth)
- Thermal time constant Parameter **P 0733(7) Ttherm** in [s]
- The shut-off threshold is 110% (reduction in current noise)

3.8 Motor protection

3.8.1 Temperature sensors

The device can evaluate different temperature sensors. With **P 0732 MON_MotorPTC** the sensor fitted in the motor and the wiring variant are set (sensor cable routed in resolver or separate). In an evaluation via KTY, the shut-off threshold of the motor temperature can additionally be set.

- KTY(84)-130
- PTC(2) = PTC sensor with short-circuit monitoring
- TSS(3) = Klixon
- PTC(4) = PTC sensor without short-circuit monitoring
- NTC 220 = NTC sensor 220 kOhm (on request) not for ServoOne junior

- NTC 1000 = NTC sensor 1000 kOhm (on request) not for ServoOne junior
- NTC 227 = NTC sensor 227 kOhm (on request) not for ServoOne junior

Temperature monitoring:

Temperature monitoring connected via:

Type:

Bild 3.8.1 Parameterization of temperature sensor

Parameters for function selection

P. no.	Parameter name/ Setting	Function
P 0731	MON_ MotorTemp_ Max	Shut-off threshold for KTY
(0)	Maximum sensor temperature X5	Factory setting 100 degrees
(1)	Maximum sensor temperature X5	Factory setting 100 degrees

P. no.	Parameter name/ Setting	Function
P 0732	MON_ MotorPTC	Selection of sensor type
(0)	OFF (0)	No evaluation
	KTY(1)	KTY84-130°
	PTC(2)	PTC to DIN 44081 with short-circuit monitoring
	TSS(3)	Klixon switch
	PTC 1(4)	PTC to DIN 44081 without short-circuit monitoring
	Not used(5)	Not assigned
	NTC 220 (6)	NTC sensor 220 kΩ ²⁾
	NTC 1000 (7)	NTC sensor 1 MΩ ²⁾
	NTC 227 (8)	NTC sensor 32 kΩ ²⁾
(1)	Connection	Termination variant
	X5(0)	Connection of the sensor to terminal X5
	X6/7(1)	Sensor connection is routed in encoder cable
	X5_X6/7(2)	Use of both inputs possible
(2)	Off(0)	No evaluation
	KTY(1)	KTY84-130°
	PTC(2)	PTC to DIN 44081 with short-circuit monitoring
	TSS(3)	Klixon switch

P. no.	Parameter name/ Setting	Function
	PTC 1(4)	PTC to DIN 44081 without short-circuit monitoring
	Not used(5)	Not assigned
	NTC 220 (6)	NTC sensor 220 kΩ ¹⁾
	NTC 1000 (7)	NTC sensor 1 MΩ ¹⁾
	NTC 227 (8)	NTC sensor 32 kΩ ¹⁾
P 0733	MON_MotorI2t	I ¹ t characteristic setting
(0)	Inom [%](0)	Rated current of the motor
(1)	I0 [%](1)	First current interpolation point of motor protection characteristic: Maximum permissible standstill current
(2)	I1 [%](2)	Second current interpolation point of motor protection characteristic referred to maximum characteristic current
(3)	F1 [Hz](3)	First frequency interpolation point of motor protection characteristic
(4)	FN / F(f) [Hz] (4)	Rated frequency
(5)	Imax [%](5)	Max. overload current referred to rated motor current
(6)	Time [sec](6)	Time for which the maximum current may be connected

P. no.	Parameter name/ Setting	Function
(7)	Ttherm	Set thermal time constant in seconds
P 0735	MON_MotorI2tType	Motor protection mode
(-1)	Off(-1)	Protection disabled
(0)	FREQU(0)	Motor frequency-dependent evaluation i(f), default setting
(1)	THERM(1)	Evaluation with thermal time constant i _{Tth} . The thermal time constant is set via parameter P 0733.7 in [s]. The shut-off threshold based on measurement tolerances is 110% of the nominal value.

Tabelle 3.8.2 Ixt setting

NOTE:



With a ServoOne junior the temperature sensor cable can be connected to both X6 and X7.

1) Does not apply to the ServoOne junior

4 Encoder

Information	
Navigation	Project tree: < Device setup < Encoder
Pictograms	 Geber
Contents	<ul style="list-style-type: none"> • Encoder selection.htm • X6 resolver channel 2 Channel 2_X6.htm • X7 SinCos channel 1 Channel 1_X7.htm • X8 technology channel 3 Channel 3_X8.htm • Redundant encoder.htm • Axis correction.htm • Encoder gearing.htm • Use of a multi-turn encoder as a single-turn encoder.htm • Increment-coded reference marks.htm • Encoder signal oversampling.htm • Overflow in multi-turn range.htm • Zero pulse test.htm

Tabelle 4.0.1 Encoder subject area

4.2 Channel 2 Resolver X6

4.2.1 Evaluation of a resolver on channel 2

For evaluation of a resolver channel 2 must always be selected. A 14-bit fine interpolation over one track signal period takes place. The pole pairs are set via P 0560 ENC_CH2_Lines.

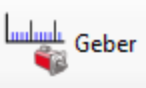
Encoder configuration channel 2 (X6)

Select from Database

Encodename

Encoder type

Number of pole pairs

Gear ratio (if encoder is not fitted at the motor)

Motor

Output drive

Signal correction (GPOC)

Bild 4.2.1 Encoder configuration channel 2 (X6)

Parameters

P. no.	Parameter name Settings	Function
P 0506	ENC_CH2_Sel	Interface configuration
(0)	OFF	No evaluation
(1)	RES	Resolver evaluation
(2)	SinCos	Resolver excitation shut-off; evaluation of a SinCos encoder or an analog clock Hall sensor (max 1kHz) possible.
P 0512	ENC_CH2_Num	Numerator of encoder gearing
P 0513	ENC_CH2_Denom	Denominator of encoder gearing
P 0560	ENC_CH2_Lines	Number of pole pairs of resolver
P 0561	ENC_CH2_Corr	Encoder correction GPOC
P 0563	ENC_CH2_EncObsMin	Amplitude monitoring Minimum
P 0564	ENC_CH2_Info	Encoder name
P 0565	ENC_CH2_LineDelay	Correction of phase shift with cable lengths > 50 m (only following consultation with LTI DRIVES GmbH).
P 0566	ENC_CH2_Amplitude	Correction of amplitude with cable lengths > 50 m (only following consultation with LTI DRIVES)

P. no.	Parameter name Settings	Function
		GmbH).
P 0567	ENC_CH2_ EncObsAct	Amplitude of analog signal

Tabelle 4.2.2 Parameter channel 2

4.3 X6 Pin assignment

Terminal assignment X6

X6	Pin no.	Resolver	Function
	1	Sin +	(S2) Analog input track A+
	2	Refsin	(S4) Analog input track A-
	3	Cos +	(S1) Analog input track B+
	4	Us +5 V + 12 V	max 250 mA: In the case of a Hiperface encoder on X7 – that is, when "Us-Switch" are connected via X7.(7) and X7.(12) – +12 V / 100 mA is applied via X7.(7) and X7.(12).
	5	⌀ (+)	PTC, KTY, Klixon
	6	Ref (+)	(R1) Analog excitation (8 kHz / 7 Vss)
	7	Ref (-)	(R2) Analog excitation
	8	Refcos	(S3) Analog input track B-
	9	⌀ (-)	PTC, KTY, Klixon

Tabelle 4.3.1 Pin assignment X6



ATTENTION:

In the case of a HIPERFACE encoder on X7 (US-Switch jumpered via X7.7 and X7.12), +12 V is connected to terminal X6.4 rather than +5 V.

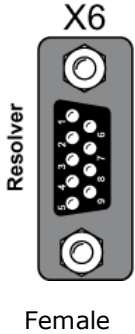
4.4 Track signal correction (GPOC)

For channels 1 and 2 the GPOC (Gain Phase Offset Correction) method can be activated for the analog track signals. This enables the mean systematic gain, phase and offset errors on the analog track signals to be detected and corrected. GPOC weights the amplitude of the complex pointer described by the track signals by special correlation methods. The dominant errors can thereby be determined very precisely, with no interference from other encoder errors, and then corrected.

4.4.1 Variants for track signal correction

- **CORR:** Track signal correction with stored values
- **ADAPT:** Track signal correction with online value tracking

Parameters

P. no.	Parameter name Settings	Function
P 0549 P 0561 P 0586	ENC_CH1/2/3_ Corr	Selection of correction method

P. no.	Parameter name Settings	Function
(0)	OFF	No method selected
(1)	CORR	Activate correction with stored values
(2)	ADAPT	Track signal correction with automatic (online) value tracking
(3)	RESET	Reset values
P 0550 P 0562 P 0587	ENC_CH1/ 2/3_ CorrVal	Signal correction / Values obtained
(0)	OffsetA	Offset, track A (sincos)
(1)	OffsetB	Offset, track B (sin)
(2)	GainA	Gain, track A (sincos)
(3)	GainB	Gain, track B (sin)
(4)	Phase	Phase

Tabella 4.4.1 Parameters for track signal correction

Correcting track signals

- Open the manual mode window and set speed-controlled mode.
- Set the optimization speed
 - Resolver: approx. 1000 to 3000 rpm

- SinCos encoder: approx. 1 to 5 rpm
- Switch to "ADAPT" during operation and wait about 1-3 minutes for the compensation algorithms to reach their steady state. The speed ripple should decrease after about 1 minute (observed with scope; actual speed value or observation of values in **P 0550, P 0562, P 0587, ENC_CH1 / CH2 / CH3_CorrVal**).
- Switching from ADAPT to CORR saves the values. If new values are to be acquired, you must switch from CORR to ADAPT and save them again.



ATTENTION:

When replacing a motor, the GPOC for the motor system must always be repeated.

4.5 Phase shift of resolver signals

With long resolver cables, a phase shift occurs between the exciter signal and tracks A/B due to the line inductance. This effect reduces the amplitude of the resolver signals after demodulation and inverts their phase in the case of very long line lengths.

The phase shift can be equalized with parameter **P 0565 ENC_CH2_LineDelay**. By way of parameter **P 0566 ENC_CH2_Amplitude** the amplitude can additionally be varied in the range -100%...+30%.
The resolver signals are plotted with the oscilloscope dependent on the setting of

parameters

P 0565 and P 0566. When the phase shift has been equalized, the settings can be saved.



NOTE:

This function is only available in ServoOne.



NOTE:

Cable lengths > 50 m only on request.

4.6 Channel 1 Interface X7

4.6.1 Channel 1: Evaluation of high-resolution encoders

SinCos encoders can be used to evaluate high-resolution encoders. A track signal period is interpolated at a 14-bit resolution (fine interpolation).

Technical data

	Specification
Interface	<ul style="list-style-type: none"> • Differential voltage input, RS422-compatible; pay attention to voltage range (TTL / 1 Vss)! • Max. cable length: 10 m

	Specification		
	<ul style="list-style-type: none"> • Connector: 15-pin D-SUB, High-Density, female • Wave terminating resistor built-in to device: 120 Ω 		
	Min.	Max.	
Input frequency	0 Hz	500 kHz	
Input voltage			
Differential switching level "High"	+0.1 V		
Differential switching level "Low"		-0.1 V	
Signal level referred to ground	0 V	+5 V	

Tabelle 4.6.1 Technical data

Encoder configuration channel 1 (X7)

Select from Database

Encodename

Cyclic position via Details

Absolute interface Details

Gear ratio (if encoder is not fitted at the motor)

Motor

Output drive

Signal correction (GPOC)

Bild 4.6.2 Encoder configuration X7

Parameters

P. no.	Settings	Function
P 0505	ENC_CH1_Sel	Configuration of the incremental interface
(0)	OFF	No evaluation
(1)	SinCos	High-resolution SinCos encoder (1 Vss) with fine interpolation
(3)	TTL	TTL encoder with zero pulse
P 0540	ENC_CH1_Abs	Determining protocol type: When starting the device and after changing the encoder parameters, the absolute position of an incremental measuring system is read out via a digital interface.
(0)	OFF	No evaluation
(1)	SSI	Serial communication to Heidenhain SSI protocol
(2)	EnDat	To Heidenhain EnDat protocol ⁽¹⁾
(3)	Hiperface	To Stegmann-Hiperface protocol ⁽¹⁾
(4)	SSI_Cont	SSI (1ms clock)
P 0542	ENC_CH1_lines	Setting of incremental pulses per revolution (value range 1 - 65536)
P 0543	ENC_CH1_Multi	Number of multi-turn bits
P 0544	ENC_CH1_Single	Number of single-turn bits
P 0545	ENC_CH1_Code	Selection of coding: Gray/binary
P 0551	ENC_CH1_	Amplitude monitoring

P. no.	Settings	Function
	EncObsMin	
P 0555	ENC_CH1_Info	Encoder name
P 0556	ENC_CH1_EncObsAct	Amplitude of analog signal
¹⁾ With EnDat and Hiperface the information on single-turn and multi-turn, coding and pulses per revolution is read automatically from the encoder (device must detect encoder product ID).		

Tabella 4.6.3 Encoder configuration X7

4.7 X7 Pin assignment

The table shows the pinning for the various encoder interfaces which can be read in via connector X7 on the ServoOne and ServoOne junior. Column 1 specifies the interface for SinCos and TTL encoders on the ServoOne. Column 2 specifies the interface for SinCos encoders on the ServoOne junior. Column 3 specifies the interface for SSI encoders and EnDat encoders, with and without SinCos track. Column 4 specifies the interface for HIPERFACE encoders. The selection is made via parameter **P 0505 ENC_CH1_Sel = 3**.

Pin assignment X7

	Pin no.	SinCos / TTL	SinCos for ServoOne junior	SSI / EnDat	HIPERFACE
 X7 Female	1	A-			REFCos
	2	A+			Cos +
	3	+5 V / max 250 mA			
	4		R+		Data +
	5		R-		Data -
	6	B -			REFSin
	7	Jumper from pin 7 to pin 12			
	8	GND			
	9	R-	PTC-		
	10	R+	PTC+		
	11	B+			Sin +
	12	Sense+			Jumper from pin 12 to pin 7
	13	Sense-			
	14			Clk+	
	15			Clk-	

Tabelle 4.7.1 Pin assignment X7



ATTENTION:

The pin assignment for evaluation of the zero pulse is different for the ServoOne and ServoOne junior.

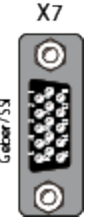

NOTE:

You will find the pin assignment for digital Hall sensors in the **Encoders < Hall sensor** subject area.



Interconnecting X7 pin 7 (US-Switch) and X7 pin 12 (Us-Switch) increases the voltage to 11.8 V on X7 pin (only for use of a HIPERFACE encoder).

In the case of a HIPERFACE encoder on X7 (US-Switch jumpered via X7.7 and X7.12), +12 V is connected to terminal X6.4 rather than +5 V.



Encoders with a voltage supply of 5 V +/- 5% must have a Sense cable connection. The sense cables are required to monitor a drop in supply voltage on the encoder cable. Only use of the sensor cables ensures that the encoder is supplied with the correct voltage.

4.8 Track signal correction (GPOC) X7

For channels 1 and 2 the GPOC (Gain Phase Offset Correction) method can be activated for the analog track signals. This enables the mean systematic gain, phase and offset errors on the analog track signals to be detected and corrected. GPOC weights the amplitude of the complex pointer described by the track signals by special correlation methods. The dominant errors can thereby be determined very precisely, with no interference from other encoder errors, and then corrected.

4.8.1 Variants for track signal correction

- **CORR:** Track signal correction with stored values
- **ADAPT:** Track signal correction with online value tracking

Parameters

P. no.	Parameter name Settings	Function
P 0549 P 0561 P 0586	ENC_CH1/2/3_ Corr	Selection of correction method
(0)	OFF	No method selected
(1)	CORR	Activate correction with stored values
(2)	ADAPT	Track signal correction with automatic (online) value tracking

P. no.	Parameter name Settings	Function
(3)	RESET	Reset values
P 0550 P 0562 P 0587	ENC_CH1/ 2/3_ CorrVal	Signal correction / Values obtained
(0)	OffsetA	Offset, track A (sincos)
(1)	OffsetB	Offset, track B (sin)
(2)	GainA	Gain, track A (sincos)
(3)	GainB	Gain, track B (sin)
(4)	Phase	Phase

Tabelle 4.8.1 Parameters for track signal correction

Correcting track signals

- Open the manual mode window and set speed-controlled mode.
- Set the optimization speed
 - Resolver: approx. 1000 to 3000 rpm
 - SinCos encoder: approx. 1 to 5 rpm
- Switch to "ADAPT" during operation and wait about 1-3 minutes for the compensation algorithms to reach their steady state. The speed ripple should decrease after about 1 minute (observed with scope; actual speed

value or observation of values in

P 0550, P 0562, P 0587, ENC_CH1 / CH2 / CH3_CorrVal).

- Switching from ADAPT to CORR saves the values. If new values are to be acquired, you must switch from CORR to ADAPT and save them again.



ATTENTION:

When replacing a motor, the GPOC for this system must always be repeated.

4.9 Cyclic evaluation of digital encoders

Cyclic encoder evaluation via channel 1 (SinCos X7)

On channel 1 (SinCos, X7) digital encoders can be cyclically read. The selection is made via **P 0505 ENC_CH1_Sel**. The number of MT/ST bits is set via parameters **P 0543** and **P 0544**.

Parameters

P. no.	Parameter name/ Setting	Function
P 0505	ENC_CH1_SEL	Encoder selection for channel 1
(0)	OFF (0)	Function disabled

P. no.	Parameter name/ Setting	Function
(1)	SINCOS(1)	SinCos encoder
(2)	SSI(2)	Digital SSI encoder
(3)	TTL(3)	TTL encoder
(4)	EnDat(4)	Digital EnDat 2.2
(5)	HALL(5)	Digital Hall sensor
P 0543	ENC_CH1_MultiT	Number of multi-turn bits
P 0544	ENC_CH1_SingleT	Number of single-turn bits
P 0553	ENC_CH1_PeriodLen	Length of a signal period
P 0554	ENC_CH1_DigitalResolution	Digital resolution (length of an increment)
P 0616	ENC_CH1_CycleCount	Sampling time (x 125 µs)

Tabelle 4.9.1 Cyclic evaluation of digital encoders



NOTE:

As encoders with different protocol modes exist (with/without error bit, parity bit, etc.), LTI DRIVES GmbH should be consulted before using them.

4.10 Channel 3 X8

4.10.1 Valid versions

When using the technology function, attention must be paid to the hardware and firmware versions of the control PCBs as per the tables.

SinCos module



Series	Variant	Hardware version	Firmware version
ServoOne Einzelachssystem 	SO82.xxx.0xx1 SO84.xxx.0xx1	from ...1.xxxx.2 from ...1.xxxx.2	from V 1.0
ServoOne Mehrachssystem 	SO84.xxx.1xx1	from ..0.1.xxxx.2	from V 1.0
ServoOne junior 	SO22.xxx.xxx1 SO24.xxx.xxx1	from ...1.xxxx.0 from ...1.xxxx.0	from V 1.10

Tabelle 4.10.1 Valid versions for the SinCos module

SSI encoder simulation





Series	Variant	Hardware version	Firmware version
ServoOne Einzelachssystem 	SO82.xxx.0xx4 SO84.xxx.0xx4	from ..0.4.xxxx.2 from ..0.4.xxxx.2	from V2.15
ServoOne Mehrachssystem 	SO84.xxx.1xx4	from ...4.xxxx.0	from V2.15
ServoOne junior 	Not available	-	-

Tabelle 4.10.2 Valid versions for SSI encoder simulation

TTL encoder simulation / TTL master encoder

Series	Variant	Hardware version	Firmware version
ServoOne Einzelachssystem 	SO82.xxx.0xx2 SO84.xxx.0xx2	from ..0.2.xxxx.2 from ..0.2.xxxx.2	All



Series	Variant	Hardware version	Firmware version
ServoOne Mehrachssystem 	SO84.xxx.1xx2	from ..0.2.xxxx.2	All
ServoOne junior 	SO22.xxx.xxx2 SO24.xxx.xxx2	from ...2.xxxx.1 from ...2.xxxx.1	from V1.10

Tabelle 4.10.3 Valid versions for TTL encoder simulation / TTL master encoder

4.11 Evaluatable encoder types

SinCos encoders are designed as optical encoders, and meet the highest accuracy demands. They emit two sinusoidal, 90° offset signals, A and B, which are scanned by analog/digital converters. The signal periods are counted and the phase angles of signals A and B are used to calculate the rotation and count direction.

Digital interface:

The digital time-discrete interface is based on a transfer protocol. The current positional information is transmitted from the encoder to the receiver. This may be done either serially or in parallel. As the transfer only takes place at certain times, it is a time-discrete interface. Encoders are specified in terms of their rated voltage and current consumption, and the pin assignment. Maximum permissible cable lengths are additionally specified.

Encoder interface X8 enables evaluation of the following encoder types. For the technical specifications of the various encoder types refer to the documentation from the encoder manufacturers.

	Encoder types
	Sin/Cos encoder with zero pulse: e.g. Heidenhain ERN1381, ROD486
	Heidenhain SinCos encoder with EnDat interface: e.g. 13-bit single-turn encoder (ECN1313) and 25-bit multi-turn encoder (EQN1325)
	Heidenhain encoder with purely digital EnDat interface: e.g. 25-bit single-turn encoder and 12-bit multi-turn encoder (EQN1337)
	SinCos encoder with SSI interface: e.g. 13-bit single-turn and 25-bit multi-turn encoders (ECN413-SSI, EQN425-SSI)
	Encoder with purely digital SSI interface: e.g. Kübler 12-bit single-turn and 12-bit multi-turn encoders (F3663.xx1x.B222)
	TTL encoder with zero pulse: e.g. Heidenhain: ROD 426, ERN 1020

Tabelle 4.11.1 Evaluatable encoder types on interface X8



Attention:

Only one encoder with a purely digital EnDat or SSI interface can be used on connector X8 or X7.

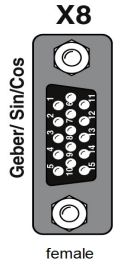
Parameters

P. no.	Setting	Function
P 0502	ENC_CH3_ActVal	Actual value parameter: Raw data of single-turn and multi-turn information.
(0)	00...00hex	Raw data – single-turn
(1)	00...00hex	Raw data – multi-turn
P 0507	ENC_CH3_Sel	Selection of encoder
(0)	OFF	No evaluation
(1)	SinCos encoder	SinCos selection
(2)	SSI encoder	SSI selection
(3)	TTL encoder	TTL selection (4)
(4)	EnDat 2.1/2.2	EnDat selection
(5)	TTL encoder with commutation signals	HALL selection (Contact LTi DRIVES GmbH)
(6)	TWINSync	TWINSync selection (Contact LTi DRIVES GmbH)
P 0514	ENC_CH3_Num	Numerator of encoder gearing
P 0515	ENC_CH3_Denom	Denominator of encoder gearing
P 0570	Absolute Position Interface select	Selector for absolute interface
(0)	OFF	No evaluation

P. no.	Setting	Function
(1)	SSI	SSI interface
(2)	EnDat	EnDat interface
P 0571	ENC_CH3_NpTest	Zero pulse test mode
(0)	OFF	Not active
(1)	ON	Zero pulse test mode active
P 0572	ENC_CH3_Lines	Setting of number of pulses (max. 65536) of TTL encoder per motor revolution: Pulses per revolution 1 - 65536
P 0573	Number of Multi Turn Bits	Number of bits of multi-turn information: Multi-turn bits 0-25 bits
P 0574	Number of Single- Turn Bits	Number of bits of single-turn information: Single-turn bits 0-29 bits
P 0575	ENC_CH3_Code	Selection of code with which the SSI encoder is to be evaluated.
(0)	BINARY (0)	Evaluation of the binary code
(1)	GRAY (1)	Evaluation of the gray code
P 0577	ENC_CH3_EncObsMin	Sensitivity for encoder monitoring (0-2)
P 0588	ENC_CH3_EncObsAct	Amplitude of analog signal (approx. 0.75 = 1 Vss)
P 0630	ENC_CH3_NominalIncrementA	Setting of the increment-coded reference marks. These values are given on the encoder data sheet.

P. no.	Setting	Function
P 0631	ENC_CH3_ NominalincrementB	Setting range 0 - 65535

Tabelle 4.11.2 Encoder interface X8

4.12 Pin assignment X8

The cable type should be chosen as specified by the motor/encoder manufacturer.

Conditions:

- Use only shielded cables.
- The shield must be applied on both sides.
- Interconnect the differential track signals A, B, R or DATA and CLK by twisted-pair cables.
- The encoder cable must not split and routed via terminals.

4.13 Pin assignment X8

The assignment of the 15-pin D-Sub female connector on slot X8 is set out in the following table.

Connection	X8	Function	Absolute value encoder
	Pin no.	SinCos encoder	SSI / EnDat
	1	A-	
	2	A+	
	3	+5 V (+/-) 5 %, I _{max} = 250 mA loop-controlled	
	4	R+	Data +
	5	R-	Data -
	6	B -	
	7		
	8	GND	
	9	R-	
	10	R+	
	11	B+	
	12	Sense cable +	
	13	Sense cable -	
	14		Clk+
	15		Clk-

Tabelle 4.13.1 Pin assignment of the SinCos module on X8

4.14 Track signal correction (GPOC) X8

For channels 1 and 2 the GPOC (Gain Phase Offset Correction) method can be activated for the analog track signals. This enables the mean systematic gain, phase and offset errors on the analog track signals to be detected and corrected. GPOC weights the amplitude of the complex pointer described by the track signals by special correlation methods. The dominant errors can thereby be determined very precisely, with no interference from other encoder errors, and then corrected.

4.14.1 Variants for track signal correction

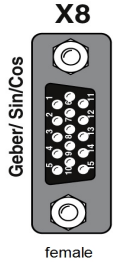
- CORR: Track signal correction with stored values
- ADAPT: Track signal correction with online value tracking

Parameters

P. no.	Parameter name Settings	Function
P 0549 P 0561 P 0586	ENC_CH1/2/3_ Corr	Selection of correction method
(0)	OFF	No method selected
(1)	CORR	Activate correction with stored values
(2)	ADAPT	Track signal correction with automatic (online) value tracking

P. no.	Parameter name Settings	Function
(3)	RESET	Reset values
P 0550 P 0562 P 0587	ENC_CH1/ 2/3_ CorrVal	Signal correction / Values obtained
(0)	OffsetA	Offset, track A (sincos)
(1)	OffsetB	Offset, track B (sin)
(2)	GainA	Gain, track A (sincos)
(3)	GainB	Gain, track B (sin)
(4)	Phase	Phase

Tabelle 4.14.1 Parameters for track signal correction

Correcting track signals

- Open the manual mode window and set speed-controlled mode.
- Set the optimization speed
 - Resolver: approx. 1000 to 3000 rpm
 - SinCos encoder: approx. 1 to 5 rpm
- Switch to "ADAPT" during operation and wait about 1-3 minutes for the compensation algorithms to reach their steady state. The speed ripple should decrease after about 1 minute (observed with scope; actual speed value or observation of values in P 0550, P 0562, P 0587, ENC_CH1/ 2/3_CorrVal).
- Switching from ADAPT to CORR saves the values. If new values are to be acquired, you must switch from CORR to ADAPT and save them again.



When a motor has to be replaced, the GPOC for the motor must always be repeated.

4.15 Technical data

TTL signal evaluation

	Specification		
Interface	<ul style="list-style-type: none"> • Differential voltage input, RS422-compatible; pay attention to voltage range! • Max. cable length: 10 m • Connector: 15-pin D-SUB, High-Density, female • Wave terminating resistor built-in to device: 120 Ω 		
	Min.	Max.	
Input frequency	0 Hz	500 kHz	
Input voltage			
Differential switching level "High"	+0.1 V		
Differential switching level "Low"		-0.1 V	
Signal level referred to ground	0 V	+5 V	

Tabella 4.15.1 Specification of the TTL encoder input on X8

Absolute value sender

	Specification		
Interface	<ul style="list-style-type: none"> • RS485-compliant • Connector: 15-pin D-SUB, High-Density, female • Wave terminating resistor built-in to device: 120 Ω 		

	Specification		
	min.	max.	typ.
Clock frequency			
EnDat		2 MHz	
SSI		1 MHz	
Output voltage	min.	max.	typ.
Signal level referred to ground	0 V	+3.3 V	-
Amount of differential output voltage	1.5 V	3.3 V	Surge impedance $\geq 57 \Omega$
Input voltage	min.	max.	typ.
Differential switching level "High"	+0.2 V		
Differential switching level "Low"		-0.2 V	
Signal level referred to ground	-7 V	+12 V	

Table 4.15.2 Specification of absolute encoder input on X8

	Specification		
	Min.	Max.	
Output voltage with SinCos, TTL, EnDat, SSI encoders	+4.75 V	+5.25 V	+5 V

	Specification		
Output current with SinCos, TTL, EnDat, SSI encoders		250 mA	

Table 4.15.3 Specification of voltage supply for external encoders on X8.

NOTE:



Any possible voltage drop in the encoder supply (5 V \pm 5%) can be compensated with the aid of the Sense cables. If the Sense cable is not used, pins 12 and 13 (+/- Sense) should be connected to pins 3 and 8 (5 V / Ground) on the encoder cable end.

The encoder supply is executed as short-circuit-proof.

4.16 Zero pulse test

To enable evaluation for the zero pulse test, parameter **P 0571 = ON (1)** is set. On the oscilloscope it can then be depicted with the measurement variables CH3-Np. To make the zero pulse clearly visible, the measurement variable remains at High level until the next zero pulse appears. Conversely, the measurement variable remains at Low level until another zero pulse appears. In this, the pulse width of the scope signal does not match the pulse width of the actual zero pulse.



Bild 4.16.1 Zero pulse recording via measurement variable CH3-zp (zp: = Zero Pulse)

NOTE:

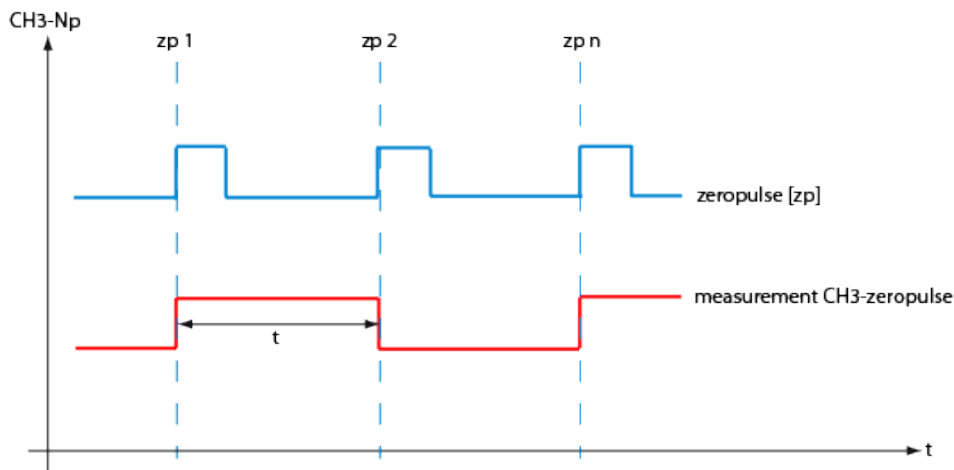

In zero pulse test mode zero pulse evaluation of homing runs is disabled. Regardless of that, all zero pulse events are counted. The zero pulse test is effected by the counter evaluation **P 0411(31)** for channel 1 and **P 0411(32)** for channel 2.

4.17 Features of the SSI encoder

Using SSI encoder simulation, the current actual position of the drive is read by a higher-level PLC. The ServoOne then behaves like an SSI encoder in relation to the PLC. SSI encoder simulation uses the technology board slot (X8). The technology board is automatically detected.

Notes on SSI resolution

The ServoOne supports transfer of a total of 32 information bits which can be broken down in any way into single-turn and multi-turn information. When generating the position information, parameter **P 0412 CON_PCON_ActPosition**, likewise presenting a 32-bit variable, is used as the data source. The 32 bits of this parameter can likewise be broken down into multi-turn and single-turn information. It is important in parameter setting that the SSI encoder simulation does not, for example, transfer more single-turn bits than correspond to the internal resolution, as they could otherwise not be filled with information. Parameter **P 0270 MPRO_FG_PosNorm** defines this resolution. The default setting for this parameter is 1048576 increments, corresponding to 2^{20} bits. With default settings the ServoOne expects 12 multi-turn and 20 single-turn bits. In this case it does not make sense to transfer more than 12 multi-turn bits, as the number overflow occurs at the 12th bit, despite a higher parameter setting. Setting the single-turn bits to > 20 likewise makes no sense, as the additional bits are always filled with 0.

Features

- Parameterizable number of multi-turn and single-turn bits (32-bit)
EnDat encoder up to 19-bit single-turn
- Transfer: Binary
- Clock rates between 200 kBit/s and 1500 kBit/s
Sampling time: minimum 125 µs
- Optional transfer with parity bit (Odd/Even)
- Optional synchronization of control to read cycle
- Display of synchronization status
- Encoder monoflop time: approx. 25 µs
- Clear parameter structure for quick and easy commissioning

4.18 Pin assignment for SSI encoder simulation

The pinout for SSI encoder simulation is executed in a 9-pin SUB-D connector with the following assignment:

Plug configuration

	Pin no.	Assignment
	1	-
	2	-
	3	GND
	4	CLK-
	5	Data +
	6	-
	7	-
	8	CLK+
	9	Data -

Tabelle 4.18.1 Pin assignment for SSI encoder simulation

4.19 Parameterization of SSI encoder simulation

SSI encoder simulation is enabled as soon as parameter **P 2800 TOPT_SSI_Mode** is set to 1. The parameter is located in the parameter group "Encoder > SSI Encoder simulation". The parameters are in the parameter group "Encoder > SSI encoder simulation", and all have the prefix "TOPT_SSI".

Parameters

P. no.	Parameter Setting	Function	
P2800	EncSimEnable	Enable SSI encoder simulation	
P2801	MultiT	Number of multi-turn bits to transfer	
P2802	SingleT	Number of single-turn bits to transfer	
P2803	Polarity	No-load level of data line	
		False	Clock line resting at Low level
		True	Clock line resting at High level
P2804	Phase	Indicates the clock edge at which new data are set	
		False	Sets data on the leading edge
		True	Sets data on the following edge
P2805	PartyEnable		Enable the parity bit
P2806	PartyType	ODD	Odd parity
		EVEN	Even parity
P2807	SyncOffset	Shift of synchronization signal to closed-loop control cycle	
P2808	SyncUse	Synchronization to read cycle	
P2809	InSync	False	ServoOne does not run synchronously with the read clock
		True	ServoOne has synchronized to the read cycle
P28010	EncobsUse	Enables transfer of an additional encoder	

P. no.	Parameter Setting	Function	
		monitoring bit	

Tabella 4.19.1 SSI encoder simulation parameters

4.20 Polarity and phase

Correct configuration of the polarity and phase is important for error-free operation of the SSI interface. The polarity setting is determined by the resting level of the SSI clock line. If the clock line rests at a Low level, parameter **P 2803 TOPT_SSI_Polarity** should be set to "False". "True" means the clock level rests at "High" level. The phase indicates the time at which a new bit is connected to the data line, and the time at which it is to be evaluated. If parameter **P 2804 TOPT_SSI_Phase** is set to False, the data are always applied back to the resting level at the edge. If the setting is "True", the data are applied away from the resting level at the edge.



Tabelle 4.20.1 Parameterization of polarity and phase

1	Bit change
2	Data transfer

Suffixing a parity bit

A parity bit can optionally be suffixed after the user data. The parity bit is then transferred after the least significant bit (LSB). The parity bit is enabled by way of parameter **P 2805 TOPT_SSI_ParityEnable**. The parity can be set either as "odd" or "even". This can be selected by way of parameter **P 0208 TOPT_SSI_Parity-Type**.

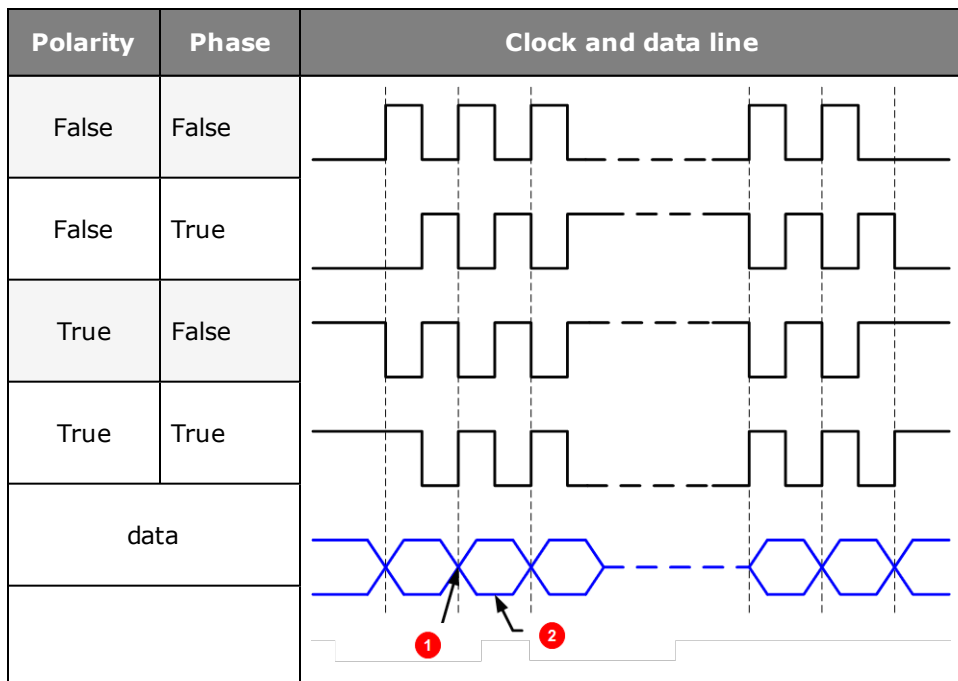
Use of synchronization

Where the SSI information is scanned at equidistant time intervals, it is possible to synchronize the control cycle of the ServoOne to the scan cycle. The synchronization is executed to the first clock edge of a transfer. When using synchronized mode, it is important that the read cycle of the control system is an integer multiple of the speed control cycle. Synchronized scanning ensures that position values polled at the equidistant time intervals can be transferred to the higher-level PLC. If multiple synchronized ServoOne units were scanned simultaneously, all actual position values would be generated at the same time. Synchronization is enabled by way of parameter **P 2808 TOPT_SSI_SyncUse**. Parameter **P 2809 TOPT_SSI_InSync** displays the synchronization status.

4.21 Scan cycle SSI information

4.21.1 Synchronization

Where the SSI information is scanned at equidistant time intervals it is possible to synchronize the control cycle of the ServoOne to the scan cycle. The synchronization is executed to the first clock edge of a transfer. When using synchronized mode, it is important that the read cycle of the PLC is an integer multiple of the speed control cycle. Synchronized scanning ensures that actual position values polled at the equidistant time intervals can be transferred to the higher-level PLC. If multiple synchronized ServoOne units are scanned simultaneously, all actual position values are generated at the same time. Synchronization is enabled by way of parameter **P 2808 TOPT_SSI_SyncUse**. Parameter **P 2809 TOPT_SSI_InSync** displays the synchronization status.

4.22 Features of the TTL module

To obtain adequate position and speed accuracy, the combined method is used. The method is a combination of edge counting and time measurement. At very low rotation speeds especially, precise determination of the position and speed values is essential.

4.22.1 Operation modes of the TTL module

- Evaluation of a TTL encoder
- Simulation of a TTL encoder (signals from other encoders are converted into TTL signals and made available as output signals for a slave axis)
- The maximum pulses per revolution is limited to 20 bits (**P 2621**).
- TTL repeater (evaluation and transmission of incoming TTL signals for additional axes)
- Simultaneous evaluation and simulation of a TTL encoder

Technical data

TTL signal evaluation

	Specification		
Interface	<ul style="list-style-type: none"> • Differential voltage input, RS422-compatible; pay attention to voltage range! • Max. cable length: 10 m • Connector: 15-pin D-SUB, High-Density, female • Wave terminating resistor built-in to device: 120 Ω 		
	Min.	Max.	
Input frequency	0 Hz	500 kHz	

	Specification		
Input voltage			
Differential switching level "High"	+0.1 V		
Differential switching level "Low"		-0.1 V	
Signal level referred to ground	0 V	+5 V	

Table 4.22.1 TTL encoder input on X8

TTL encoder simulation

	Specification		
Interface	<ul style="list-style-type: none"> • RS422-compliant • Electrically isolated from the drive controller • Connector: 15-pin D-SUB, High-Density, female 		
	Min.	Max.	
Output frequency	0 Hz	1000 kHz	
Output voltage			
Signal level referred to ground	0 V	+5 V	
Differential output voltage U	2.0 V	5.0 V	Wave terminating resistance $\geq 100 \Omega$

Table 4.22.2 TTL encoder simulation on X8

Voltage supply to external encoder

	Specification		
	Min.	Max.	
Output voltage	+ 4.75 V	+ 5.25 V	+5 V
Output current		250 mA	

Tabelle 4.22.3 Voltage supply for external encoders on X8

4.23 Pin assignment of TTL encoder

The pinout for the TTL encoder is executed in a 15-pin SUB-D connector (X8) with the following assignment:



NOTE:

No provision is made for connection of sensor cables to compensate for the voltage drop. So the chosen supply cable cross-section should take account of the voltage drop.



NOTE:

The encoder supply on X8/3 is short-circuit-proof.

Connection	X8 pin no.	Assignment TTL encoder	Assignment TTL encoder simulation
 <p>Female</p>	1	A-	-
	2	A+	-
	3	+5 V (+/-) 5%, I _{max} = 250 mA loop-controlled	-
	4	-	A+
	5	-	A-
	6	B -	-
	7	-	R+ (zero pulse)
	8	+5 V	-
	9	R- (zero pulse)	-
	10	R+ (zero pulse)	-
	11	B+	-
	12	-	R- (zero pulse)
	13	-	GND
	14	-	B+
	15	-	B -

Tabelle 4.23.1 Pin assignment of TTL encoder

Cable type and layout

The cable type should be chosen as specified by the motor/encoder manufacturer.

Recommended:

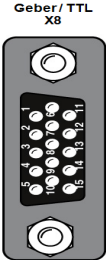
- TTL signal evaluation: 3 x 2 x 0.14 mm² and 1 x 2 x 0.5 mm²
- TTL encoder simulation: 4 x 2 x 0.14 mm²

The following conditions must be met:

- Use only shielded cables.
- Shield on both sides.
- Interconnect the differential track signals A, B and R by twisted cable strands.
- Do not separate the encoder cable, for example to route the signals via terminals in the cabinet.

4.24 Parameterization of the TTL encoder

4.24.1 Interface configuration of encoder for loop control

By way of **P 0520**, **P 0521**, **P 0522** the physical encoder interface is adapted to the current, speed or position controller.

Parameters

P. no.	Parameter Setting	Function
P 0520	ENC_MCon Encoder	Selection of encoder channel for commutation angle and current control. Feedback signal for field-oriented regulation.

P. no.	Parameter Setting	Function
P 0521	ENC_SCon Encoder	Selection of encoder channel for speed configuration. Feedback signal for speed controller
P 0522	ENC_PCon Encoder	Selection of encoder channel for position information. Feedback signal for position controller
Parameter settings apply to P 0520, P 0521, P 0522		
(0)	Off	
(1)	CH1	
(2)	CH2	
(3)	CH3	

Tabelle 4.24.1 Parameterization of encoder interface

4.24.2 Configuration of TTL encoder simulation and repeater mode

The TTL module can simulate a TTL encoder with the aid of encoder simulation. In this, the encoder simulation forms incremental encoder-compatible pulses from the position of the rotary encoder connected to the motor. Two 90° offset signals are generated on tracks A and B as well as a zero pulse (track R). The pulses per revolution of the encoder simulation can be set over a range from 0 to 65535 by way of **P 2621**.

In repeater mode (only TTL signals can be evaluated) the TTL signal connected to X7 or X8 is outputted by way of encoder simulation. The transmission is isolated. The signal delay of the repeater function is < 2 µs.



Bild 4.24.1 Pulse direction signals

Parameters

P. no.	Parameter Setting	Function
P2825	EncSimSel	Configuration of signal selection Encoder simulation (1) to (5) Repeater mode (6), (7)
(0)	OFF	Function not active
(1)	Act.Pos	Actual position value
(2)	Act.Pos.Inv	Actual position value inverted
(3)	Ref.Pos	Position reference value
(4)	Ref.Pos.Inv	Position reference value inverted
(5)	Virtual Master	Virtual position of the module

P. no.	Parameter Setting	Function
(6)	Repeater X7	Repeater mode active, TTL input signals on X7/8 are outputted without taking into account the preset pulses per revolution in parameter P 2621 by way of encoder simulation.
(7)	Repeater X8	
P2621	EncSimLines 1.. 2 ²⁰	Configuration of pulses per revolution for encoder simulation
P2622	EncSimIndexPulse 0...65535	Position of the zero pulse scaled to 216 per revolution (360°)

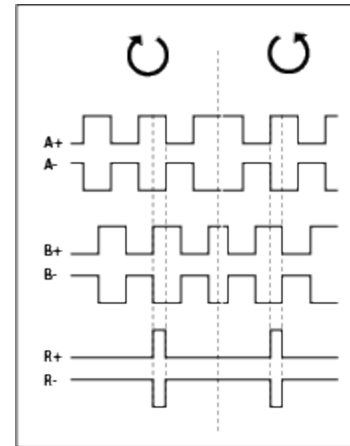
Tabelle 4.24.2 Selector settings

Pulses per revolution	Encoder simulation rpm	Master encoder input rpm
8192	6000	3000
16384	3660	1830
32768	1830	915

Tabelle 4.24.3 Rotation speeds for high pulses per revolution (max. signal frequency)

4.25 Parameterization of the TTL encoder channel

The schematic shows the signal curve and the selection of the signal sources.

Signal sources:

- TTL encoder with zero pulse
- Master encoder signal with two 90° offset track signals A/B
- Pulse/direction signal e.g. from a stepper motor control



Bild 4.25.1 Parameterization of encoder channel X8

1	Selection of encoder
2	Zero pulse test mode
3	Setting of signal type and pulses per revolution
4	Gear transmission ratio
5	Actual value (encoder raw data)

Parameters

P. no.	Parameter Setting	Function
P 0502	ENC_CH3_ ActVal	Actual value parameter: Raw data of single-turn and multi-turn information to test encoder evaluation.
(0)	Single-turn 00...00 hex	The raw data are processed after the electronic gearing and before the scaling [unit in increments]
(1)	Multi-turn 00...00hex	
P 0507	ENC_CH3_ Sel	Selection of encoder
(0)	Off	No function
(1)	SinCos encoder	Not active
(2)	SSI encoder	Not active
(3)	TTL encoder	TTL encoder with zero pulse
(4)	EnDat	Not active
(5)	TTL encoder with commutation signals	Not active
(6)	TWINSync	Not active
P 0514	ENC_CH3_	Numerator of encoder gearing

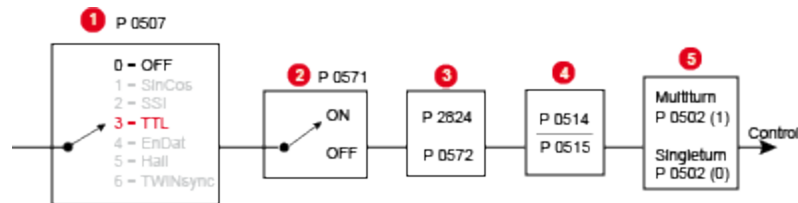
P. no.	Parameter Setting	Function
	Num - $(2^{31}).. + (2^{31}-1)$	
P 0515	ENC_CH3_Denom 1... $(2^{31}-1)$	Denominator of encoder gearing
P 0571	ENC_CH3_NpTest	Zero pulse wiring test (more details following)
(0)	Off	No function
(1)	On	Zero pulse test mode active
P 0572	ENC_CH3_Lines Pulses per revolution [1-65536]	Setting of number of pulses per motor revolution (1- 65536) of TTL encoder
P2824	ENC_CH3_TTL_SignalType	Signal type (see table)

Tabelle 4.25.2 Basic setting of encoder channel

TTL signal types

Setting	Function	Example
AF_B (0)	<ul style="list-style-type: none"> TTL signals (track A, track B) Direction of rotation of "slave axis" equal to "master axis" 	
AR_B (1)	<ul style="list-style-type: none"> TTL signals (track A, track B) Direction of rotation of "slave axis" in inverse proportion to "master axis" 	
ABDFN (2)	<ul style="list-style-type: none"> Pulse-direction signals (track A: pulse; track B: direction) With a rising edge of track B positive direction Only falling edges of track A are evaluated. 	
ABDRP (3)	<ul style="list-style-type: none"> Pulse-direction signals (track A: pulse; track B: direction) With a falling edge of track B negative direction Only rising edges of track A are evaluated. 	

Tabelle 4.25.3 Function description – parameter P 2824 (SignalType)

4.26 TTL encoder zero pulse test

To enable evaluation for the zero pulse test, parameter **P 0571 = ON (1)** is set. On the oscilloscope it can then be depicted with the measurement variables CH3-Np. To make the zero pulse clearly visible, the measurement variable remains at High level until the next zero pulse appears. Conversely, the measurement variable remains at Low level until another zero pulse appears. In this, the pulse width of the scope signal does not match the pulse width of the actual zero pulse.



Bild 4.26.1 Zero pulse recording via measurement variable CH3-zp (zp: = zero pulse)

NOTE:

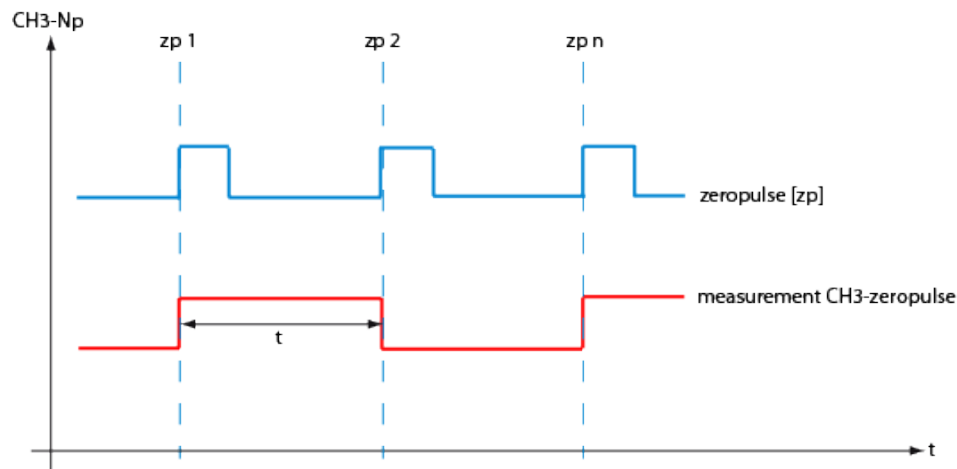

In zero pulse test mode zero pulse evaluation of homing runs is disabled. Regardless of that, all zero pulse events are counted. The zero pulse test is effected by the counter evaluation **P 0411(31)** for channel 1 and **P 0411(32)** for channel 2.

4.27 Technical data

TTL evaluation

- Processing of three differentially executed autocommutation signals, to determine the rotor position.
- The rotor position is resolved into six segments per pole pair and is updated during operation by way of the commutation signals.

TTL encoder

	Specification		
Interface	<ul style="list-style-type: none"> • Wave terminating resistor built-in to device: 120 Ω • Max. cable length: 10 m • Connector: 15-pin D-SUB, High-Density, female 		
	Min.	Max.	
Input frequency	0 Hz	500 kHz	

	Specification		
Input voltage: Track A, B, R	Differential input RS422-compatible; pay attention to voltage range.		
Differential switching level "High"	+0.1 V		
Differential switching level "Low"		-0.1 V	
Signal level referred to ground	0 V	+5 V	
Input voltage: Track U, V, W	RS422-compliant		
Differential switching level "High"	+0.2 V		
Differential switching level "Low"		-0.2 V	
Signal level referred to ground	-7 V	+12 V	
<ul style="list-style-type: none"> • Output voltage • Output current 	+4.74 V	+5.25 V 250 mA	+5 V

Tabelle 4.27.1 Electrical specification of voltage supply for external encoder on X8



NOTE:

The encoder supply on X8/3 is short-circuit-proof.

4.28 Pin assignment of TTL with commutation signals

The assignment of the 15-pin D-SUB female connector on slot X8 is set out in the following table.

Connection	X8 pin no.	Assignment TTL encoder with commutation signals
 <p>Geber/TTL X8</p>	1	A-
	2	A+
	3	+5 V (+/-) 5%, I _{max} = 250 mA loop-controlled
	4	U +
	5	U -
	6	B -
	7	W +
	8	GND
	9	R- (zero pulse)
	10	R+ (zero pulse)
	11	B+
	12	W -
	13	-
	14	V+
	15	V -

Tabelle 4.28.1 Pin assignment of TTL encoder with commutation signals on X8.

4.29 Parameterization of TTL encoder with commutation signals

4.29.1 Interface configuration of encoder for closed-loop control

By way of **P 0520**, **P 0521**, **P 0522** the physical encoder interface is adapted to the current, speed or position controller.

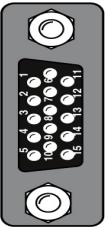
P. no.	Parameter Setting	Function
P 0520	ENC_MCon Encoder	Selection of encoder channel for commutation angle and current control. Feedback signal for field-oriented regulation.
P 0521	ENC_SCon Encoder	Selection of encoder channel for speed configuration. Feedback signal for speed controller
P 0522	ENC_PCon Encoder	Selection of encoder channel for position information. Feedback signal for position controller
Parameter settings apply to P 0520 , P 0521 , P 0522		
(0)	Off	
(1)	CH1	
(2)	CH2	
(3)	CH3	

Tabelle 4.29.1 Parameterization of encoder interface

4.30 Parameterization of TTL encoder channel with commutation signals

The schematic shows the signal curve and the selection of the signal sources.

Signal sources:

- TTL encoder with zero pulse
- TTL encoder with zero pulse and U, V, W commutation signals

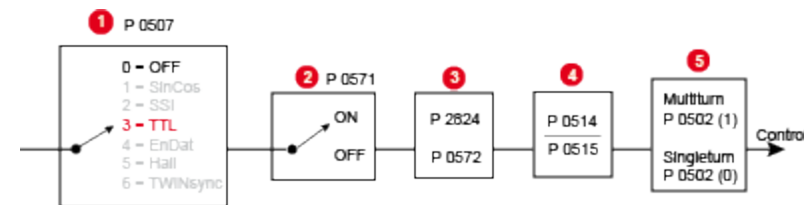

1	Selection of encoder
2	Zero pulse test mode
3	Setting of signal type and pulses per revolution
4	Gear transmission ratio
5	Actual value (encoder raw data)

Parameter setting Encoder channel X8

P. no.	Parameter Setting	Function
P 0502	ENC_CH3_ActVal	Actual value parameter: Raw data of single-turn and multi-turn information to test encoder evaluation.
(0)	Single-turn 00...00 hex	The raw data are processed after the electronic gearing and before the scaling [unit in increments]
(1)	Multi-turn 00...00hex	
P 0507	ENC_CH3_Sel	Selection of encoder
(0)	Off	No function
(1)	SinCos encoder	Not active
(2)	SSI encoder	Not active
(3)	TTL encoder	TTL encoder with zero pulse
(4)	EnDat	Not active
(5)	TTL encoder with commutation signals	Not active
(6)	TWINSync	Not active

P. no.	Parameter Setting	Function
P 0514	ENC_CH3_Num $-(2^{31}).. + (2^{31}-1)$	Numerator of encoder gearing
P 0515	ENC_CH3_Denom $1...(2^{31}-1)$	Denominator of encoder gearing
P 0571	ENC_CH3_NpTest	Zero pulse wiring test (more details following)
(0)	Off	No function
(1)	On	Zero pulse test mode active
P 0572	ENC_CH3_Lines Pulses per revolution [1-65536]	Setting of number of pulses per motor revolution (1- 65536) of TTL encoder
P2824	ENC_CH3_TTL_SignalType	Signal type (see table)

Tabella 4.30.1 Basic setting of encoder channel

TTL signal types

Setting	Function	Example
AF_B (0)	<ul style="list-style-type: none"> TTL signals (track A, track B) Direction of rotation of "slave axis" equal to "master axis" 	
AR_B (1)	<ul style="list-style-type: none"> TTL signals (track A, track B) Direction of rotation of "slave axis" in inverse proportion to "master axis" 	
ABDFN (2)	<ul style="list-style-type: none"> Pulse-direction signals (track A: pulse; track B: direction) With a rising edge of track B positive direction Only falling edges of track A are evaluated. 	
ABDRP (3)	<ul style="list-style-type: none"> Pulse-direction signals (track A: pulse; track B: direction) With a falling edge of track B negative direction Only rising edges of track A are evaluated. 	

Tabelle 4.30.2 Function description – parameter P 2824 (SignalType)

4.31 Zero pulse test

To enable evaluation for the zero pulse test, parameter **P 0571 = ON (1)** is set. On the oscilloscope it can then be depicted with the measurement variables CH3-Np. To make the zero pulse clearly visible, the measurement variable remains at High level until the next zero pulse appears. Conversely, the measurement variable remains at Low level until another zero pulse appears. In this, the pulse width of the scope signal does not match the pulse width of the actual zero pulse.



Bild 4.31.1 Zero pulse recording via measurement variable CH3-zp

NOTE:

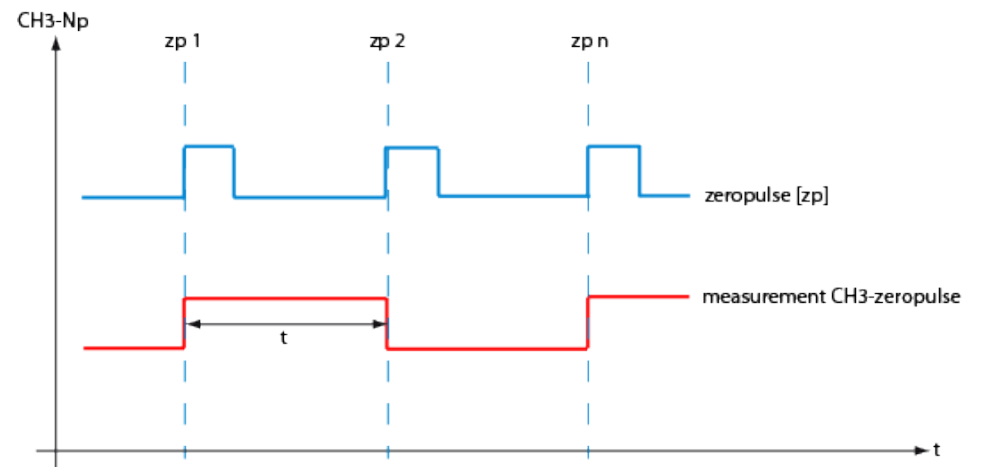

In zero pulse test mode zero pulse evaluation of homing runs is disabled. Regardless of that, all zero pulse events are counted. The zero pulse test is effected by the counter evaluation **P 0411(31)** for channel 1 and **P 0411(32)** for channel 2.

4.32 Redundant encoder

4.32.1 Monitoring the position difference

It is possible to set the position difference between the positioning encoder and a redundant encoder. In this, parameter

P 0524 is used to set the channel of the redundant position encoder and parameter

P 0597 specifies the maximum position difference in increments. Monitoring is not active if **P 0524 = 0** and the drive has been referenced. It is reset when the associated error is acknowledged or homing is executed again.

Parameters

P. no.	Parameter name/ Setting	Function
P 0524	ENC_ EncRedPos	Selection of the channel (1-3) with which the position encoder is to be evaluated.
P 0597	ENC_ RedPos_ DiffMax	Setting of the maximum position difference in increments.

Tabelle 4.32.1 Monitoring the position difference

4.33 Axis correction

4.33.1 Deviation of actual position value

The actual position value delivered by the encoder system and the real actual position value on the axis may vary for a number of reasons. Such non-linear inaccuracies can be compensated by axis error correction (using position- and direction-dependent correction values). For this, a correction value table is filled with values for each of the two directions. The respective correction value is produced from the current axis position and the direction of movement by means of cubic, jerk-stabilized interpolation. The actual position value is adapted on the basis of the corrected table. Both tables contain 250 interpolation points.

The correction range is within the value range delimited by parameters **P 0591 ENC_ACOR_PosStart** "Start position" and **P 0592 ENC_ACOR_PosEnd** "End position correction". The start position is preset on the user side; the end position is determined on the drive side.

Possible cause of deviations

- Inaccuracy of the measuring system
- Slack in mechanical elements such as the gearing, coupling, feed spindle etc.
- Thermal expansion of machine components.



Bild 4.33.1 Slack between two mechanical components

1	Slack in the mechanism
----------	------------------------

Parameters

P. no.	Parameter name Setting	Function
P 0530	ENC_ Encoder1Se	Channel selection for the 1st encoder used
P 0531	ENC_ Encoder2Sel	Channel selection for the 2nd encoder used
P 0590	ENC_ACOR_ Sel	

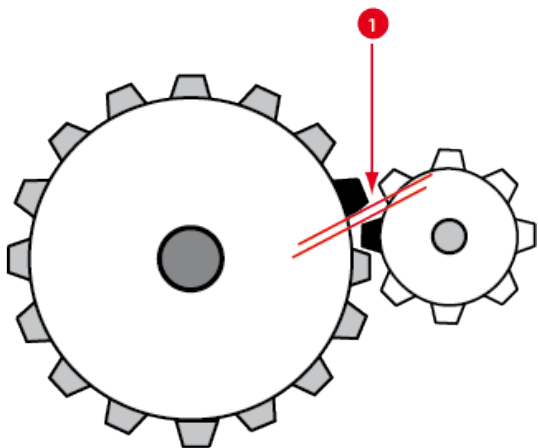
P. no.	Parameter name Setting	Function
(0)	OFF	No encoder selected
(1)	1. encoder	1st encoder selected
(2)	2. encoder	2nd encoder selected
P 0591	ENC_ACOR_ PosStart	Definition of correction range: The range is defined by parameters P 0591 ENC_ACOR_PosStart Start position and P 0592 ENC_ACOR_PosEnd end position. The start position is user-specified; the end position is determined on the device side from the maximum value of correction table interpolation points used and the interpolation point pitch
P 0592	ENC_ACOR_ PosEnd	
P 0593	ENC_ACOR_ PosDelta	Interpolation point pitch: The positions at which the correction interpolation points are plotted are defined via parameters P 0593 ENC_ACOR_PosDelta Interpolation point pitch and P 0591 ENC_ACOR_PosStart Start position. Between the correction interpolation points, the correction values are calculated by cubic spline interpolation.
P 0594	ENC_ACOR_ Val	Actual position
P 0595	ENC_ACOR_ VnegTab	Values of the correction table for negative direction of rotation in user units.
P 0596	ENC_ACOR_ VposTab	Values of the correction table for positive direction of rotation in user units.

Vorgehensweise: Axis correction

- With **P 0530 ENC_Encoder1Sel** channel selection for SERCOS: 1st encoder
- With **P 0531 ENC_Encoder2Sel** channel selection for SERCOS: 2nd encoder
- Selection of the encoder whose actual position value is to be changed, with **P 0590 ENC_ACOR_Sel**
- Enter interpolation point pitch in **P 0593 ENC_ACOR_PosDelta**
- The correction values are determined using a reference measurement system (e.g. laser interferometer). The interpolation points for the various directions within the desired correction range are approached one after another and the corresponding position error is measured.
- The interpolation point-specific correction values are entered manually in tables
P 0595 ENC_ACOR_VnegTab (neg. direction) and
P 0596 ENC_ACOR_VposTab (pos. direction).
- Save values



- Restart



- **P 0592 ENC_ACOR_PosEnd** now shows the position end value of the correction range
- Start control (in position control execute homing) and then move to any position.
- The momentary correction value is written to **P 0594 ENC_ACOR_Val**. This value is subtracted from the approached position value. This applies to all positions.

End position = interpolation point pitch multiplied by number of

interpolation points (table values) + start position (only if start position ≠ 0).

4.33.2 Determining the direction of movement

Position control

The direction of movement is produced when the time-related change in position reference (speed pre-control value) has exceeded the amount of the standstill window in the positive or negative direction.

Speed control

The direction of movement is produced when the speed reference has exceeded the amount of the standstill window in the positive or negative direction.



Bild 4.33.1 Corrected actual position value

NOTE:

Parameterization is carried out in the selected user unit for the position as integer values. It is advisable to use the same number of correction interpolation points for the positive and negative directions. The first and last correction values in the table must be zero in order to avoid instability (step changes) of the actual position value. Differing correction values for the positive and negative directions at the same interpolation point will lead to instability in the associated actual position value when the direction is reversed, and so possibly to a step response adjustment to the reference position.

4.34 Encoder gearing

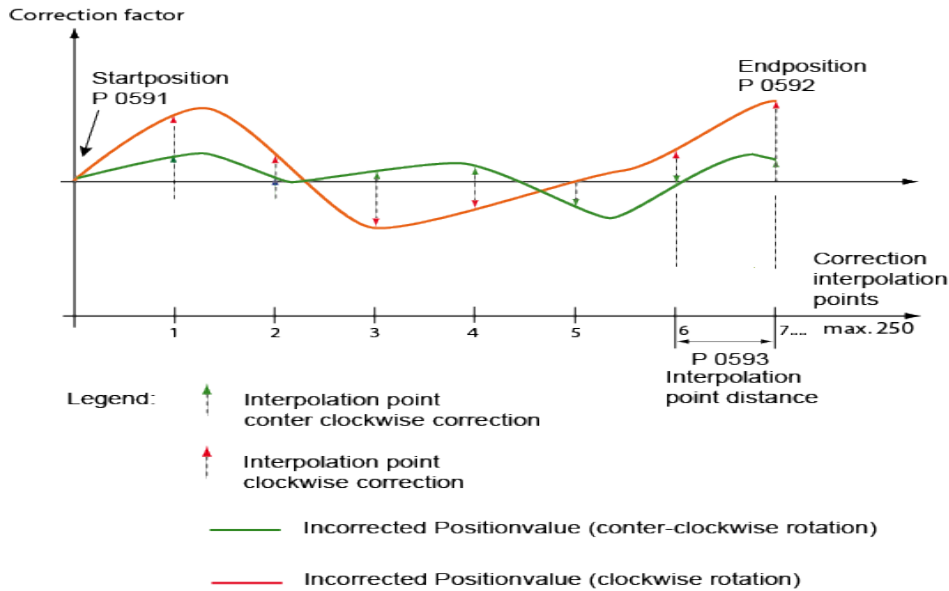
For channels 1 and 3 one gear ratio each can be set for the encoder. Using the gear ratio permits adaptation of an encoder mounted on the load side to the motor shaft. For encoder channel 2 it is to be assumed that the resolver is always mounted on the motor shaft. The adjustment range is therefore limited to (+1) or (-1), meaning the encoder signal can only be inverted.

Parameters

P. no.	Designation	Function
P 0510	ENC_CH1_Num	Denominator of channel 1
P 0511	ENC_CH1_Denom	Numerator of channel 1
P 0512	ENC_CH2_Num	Denominator of channel 2
P 0513	ENC_CH2_Denom	Numerator of channel 2
P 0514	ENC_CH3_Num	Denominator of channel 3
P 0515	ENC_CH3_Denom	Numerator of channel 3

Tabelle 4.34.1 Parameters for encoder transmission ratio

4.35 Multi-turn encoder as single-turn encoder

By way of parameters **P 0548 ENC_CH1_MTEEnable = 1** and **P 0585 ENC_CH3_MTEEnable = 1** a multi-turn encoder can be run as a single-turn encoder.

4.36 Increment-coded reference marks

In the case of encoders with increment-coded reference marks, multiple reference marks are distributed evenly across the entire travel distance. The absolute position information, relative to a specific zero point of the measurement system, is determined by counting the individual measuring increments between two reference marks. The absolute position of the scale defined by the reference mark is assigned to precisely one measuring increment. Before an absolute reference can be created or the last selected reference point found, the reference mark must be passed over. In the worst-case scenario this requires a rotation of up to 360°. To determine the reference position over the shortest possible distance, encoders with increment-coded reference marks are supported (e.g. HEIDENHAIN ROD 280C).

The reference mark track contains multiple reference marks with defined increment differences. The tracking electronics determines the absolute reference when two adjacent reference marks are passed over after just a few degrees of rotation.

Rotary system

Number of pulses P 0572	Number of reference marks	Basic increment G Nominal Increment A P 0630	Basic increment G Nominal increment B P 0631
18 x 1000	18 basic marks	Reference measure A =	Reference measure B

Number of pulses P 0572	Number of reference marks	Basic increment G Nominal Increment A P 0630	Basic increment G Nominal increment B P 0631
lines	+ 18 coded marks = Σ 36	1000 lines corresponding to 20°	1001 lines

Tabelle 4.36.1 Example of a rotary system



Bild 4.36.2 Schematic view of circular graduations with increment-coded reference marks

1	Increment-coded reference measure B, large increment (1001 lines): P 0631 ENC_CH3_NominalIncrementB
2	Increment-coded reference measure A, small increment (1000 lines):

	P 0630 ENC_CH3_NominalIncrementA
3	Zero point: The pulses per revolution are entered in parameter P 0572 ENC_CH3_Lines (e.g. 18x1000). A sector increment difference of +1 and +2 is supported. One mechanical revolution is precisely one whole multiple of the basic increment A.

Tabelle 4.36.3 Reference marks

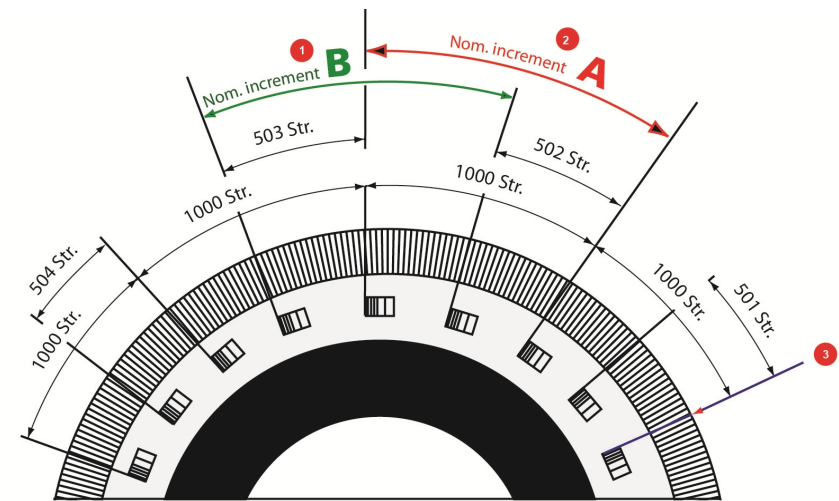
2	Reference marks
3	Increment-coded reference measure A (small reference mark interval) (P 0630 ENC_CH3_NominalIncrement A)
4	Increment-coded reference measure B (large reference mark interval) (P 0631 ENC_CH3_NominalIncrement B)

Tabelle 4.36.5 Reference marks, linear system

Linear system



Bild 4.36.4 Schematic for a linear scale

1	Pitch periods (TP): (P 0572 ENC_CH3_Number of lines)
---	---

Homing method for increment-coded encoders:

Method -6: Increment-coded encoders with negative direction of rotation

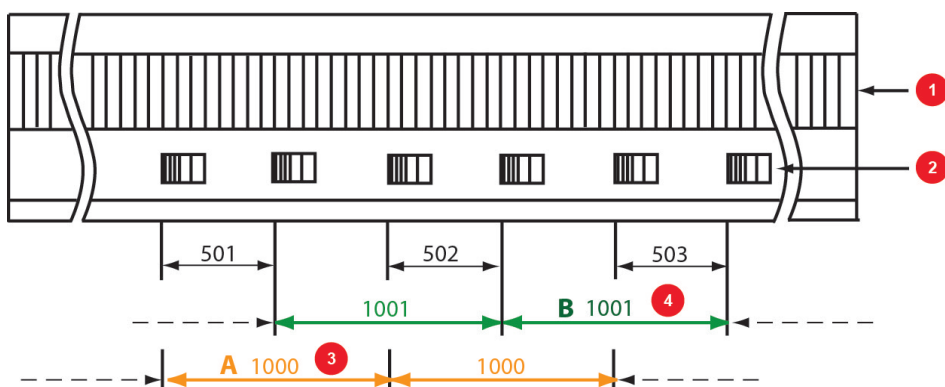
Method -7: Increment-coded encoders with positive direction of rotation

4.37 Encoder signal oversampling

Encoder signal oversampling optimizes the accuracy of resolver and SinCos signals. Not applying asynchronous intermediate measurements leads to lesser rounding errors and a generally better quality of encoder signals.

Parameters

P. no.	Designation	Function
P1956	CON_ACT_Ovrs	Encoder signal oversampling. This function applies only to resolver and SinCos signals
(0)	0	Oversampling disabled

P. no.	Designation	Function
	1	Oversampling enabled
(1)	pmeas	The percentage measuring time for oversampling dependent on the sampling time
(2)	filtershift	Limit frequency for the oversampling filter
	4	6666 Hz
	5	3333 Hz
	6	1666 Hz
	7	844 Hz
(3)	sourceselect	Oversampling signal source
	0	Oversampling for Sin/Cos signals (X7)
	1	Oversampling for resolver signals (X6)

Tabelle 4.37.1 Parameter setting for oversampling

errors. If the oversampling units are used, it must always be certain that the encoder does not dramatically exceed the specified limit frequencies.

4.38 Overflow in multi-turn range

4.38.1 Overflow shift in multi-turn range:

With this function the multi-turn range can be shifted in order to avoid a possible overflow. The function is available for encoder channels 1 and 3.

Example:

If a portion of the travel distance is to the left of the threshold (MT Base), it is appended to the end of the travel range (to the right of the 2048) via parameter **P 0547 ENC_CH1_MTBBase** for encoder channel 1 and **P 0584 ENC_CH3_** for encoder channel 3 (unit: increments).



ATTENTION:

When oversampling is enabled, instead of the normal A/D signals the oversampled signals for the encoder specified in parameter 1956[3] are used. In the case of high-track Sin/Cos encoders in particular, the low limit frequency of the oversampling filters may result in quadrant



Bild 4.38.1 Multi-turn range

Parameters

P. no.	Parameter name	Function
P 0547	ENC_CH1_MTBBase	Input of multi-turn position "MTBase" in increments (default: 1 revolution = 20 bits).
P 0584	ENC_CH3_MTBBase	Input of multi-turn position "MTBase" in increments (default: 1 revolution = 20 bits).

Tabelle 4.38.2 Overflow shift

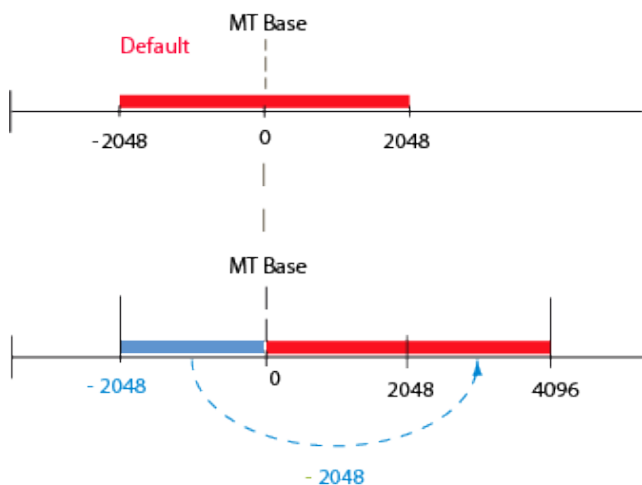
4.39 Zero pulse test

To enable evaluation for the zero pulse test, parameter **P 0541/P 0571 = ON (1)** is set. On the oscilloscope it can then be depicted with the measurement variables CH1/3-Np. To make the zero pulse clearly visible, the measurement variable remains at High level until the next zero pulse appears. Conversely, the measurement variable remains at Low level until another zero pulse appears. In this, the pulse width of the scope signal does not match the pulse width of the actual zero pulse.



Bild 4.39.1 Zero pulse recording via measurement variable CH1/3-zp (zero pulse)

NOTE:

In zero pulse test mode zero pulse evaluation of homing runs is disabled.

Regardless of that, all zero pulse events are counted. The zero pulse test is effected by the counter evaluation **P 0411(31)** for channel 1 and **P 0411(32)** for channel 2.

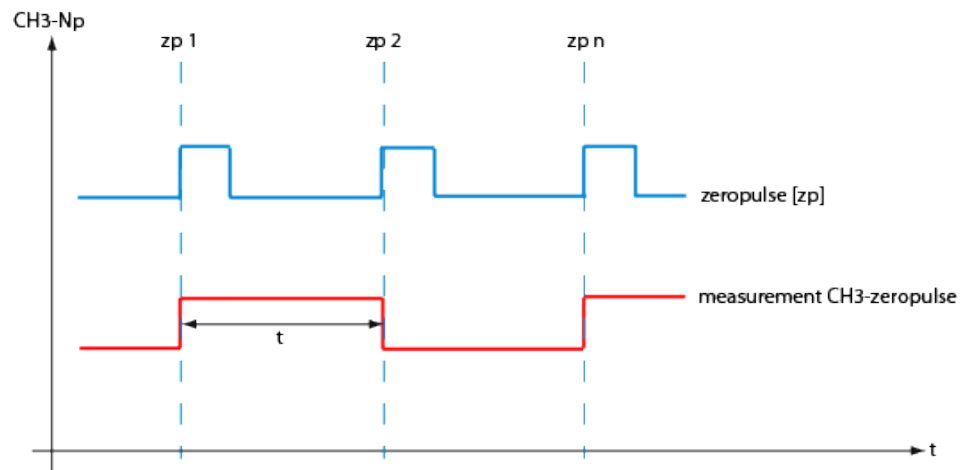
5 Closed-loop control

Information	
Navigation	Project tree: < Device setup < Closed-loop control
Pictograms	 Regelung
Contents	<ul style="list-style-type: none">• Basic settings: Control basic setting.htm• Torque control: Analysis of torque control.htm• Analysis of speed control: Analysis of speed control.htm• Position control: Position control setup.htm• ASM field-weakening.htm• SM voltage controller field-weakening.htm• Autocommutation.htm• Commissioning: Current controller autotuning.htm• V_f mode.htm• Process controller: Function_Control structure_Setup.htm

Tabelle 5.0.1 Closed-loop control subject area

5.1 Control basic setting

A servocontroller works on the principle of field-oriented regulation. In the motor the current is injected so that the magnetic flux is at the maximum and a maximum torque can be generated on the motor shaft or on the carriage of a linear motor.

The closed-loop control is cascaded. The position, speed and current controllers are configured in sequence. The sequence of controller setup must always be observed in controller optimization.

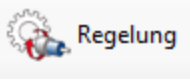
1. Current controller setup
2. Speed controller setup
3. Position controller setup/pre-control

The overall structure of the control loops is set out in the control loop schematic.



Bild 5.1.1 Closed-loop control schematic

Sampling times of the individual control loops (switching frequency 8 kHz)

- Current/torque controller = 62.5 μ s
- Speed controller = 125 μ s
- Position controller = 125 μ s

Specified features of a well configured control:

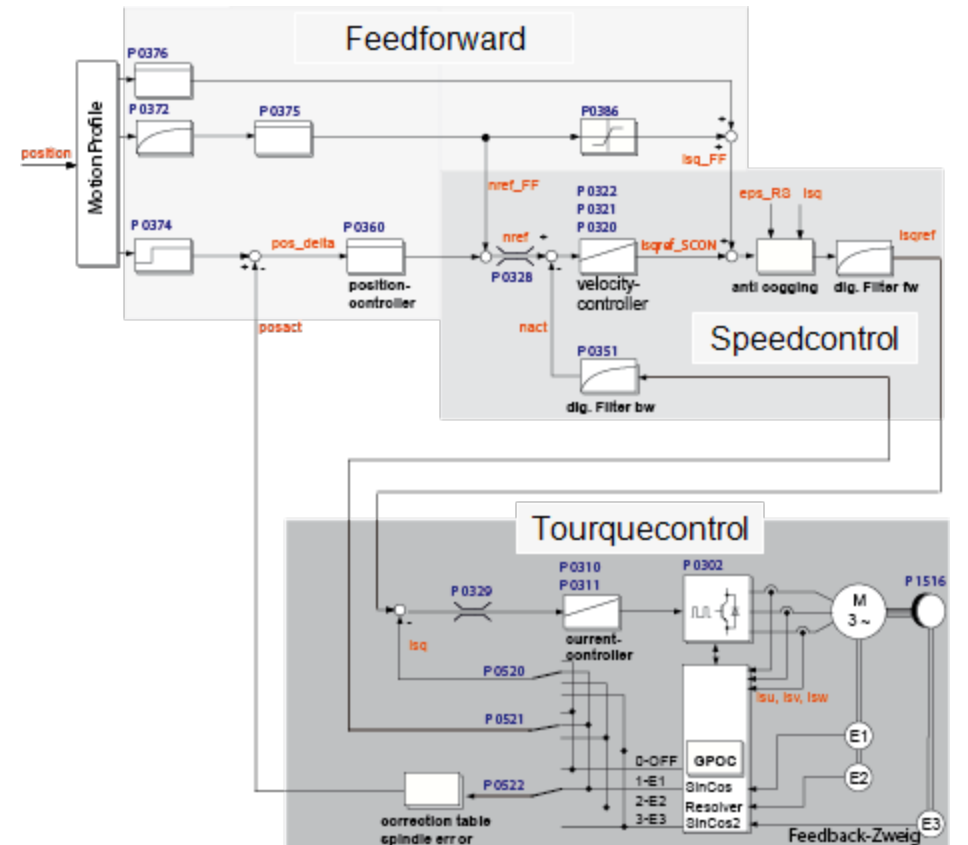
- Constant speed (synchronism)
- Positioning accuracy (absolute and repeatable)
- High dynamism
- Constant torque
- Disturbance adjustment

Setting

When using a LTI DRIVES GmbH standard motor data set, the control parameters are preset for the specific motor model (external mass inertia = motor inertia). If using third-party motors, a manual setting must be made for the drive by way of the motor identification or by calculation in order to define the appropriate control parameters for the motor model.

Speed control loop:

The setting of the speed controller with the associated filters is dependent on the motor parameters (moment of inertia, torque/force constant, load inertia/mass, friction, rigidity of the connection and encoder quality). Consequently, a manual or automatic optimization is often required.

Position control loop

The position control loop is dependent on the dynamism of the underlying speed controller, on the setpoint (reference) type and on the jerk, acceleration and interpolation methods.

5.2 Motor control setup

The basic settings for the control are selected and parameterized using the "Motor control setup" dialog box. This dialog box aids navigation to the basic settings, various controllers and the control mode.



Bild 5.2.1 Motor control setup dialog box

5.2.1 Motor control basic setting

Click on the "Basic settings" button opens the wizard to determine the mass inertia, the rigidity wizard, as well as the speed and position controllers.

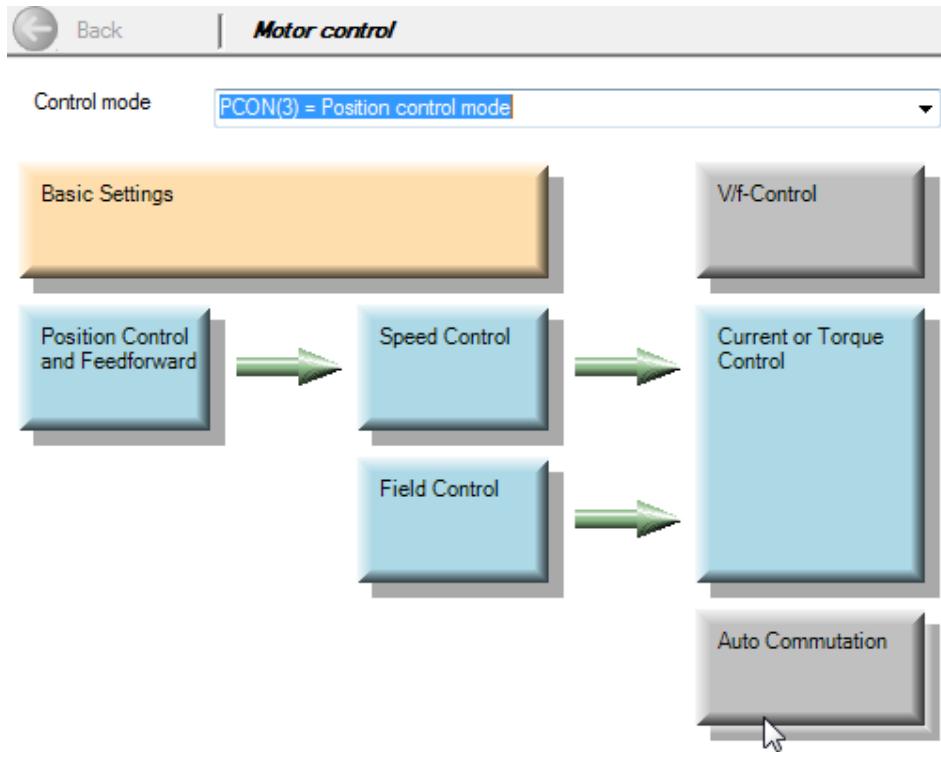

Bild 5.2.1 Motor control basic setting

ATTENTION:

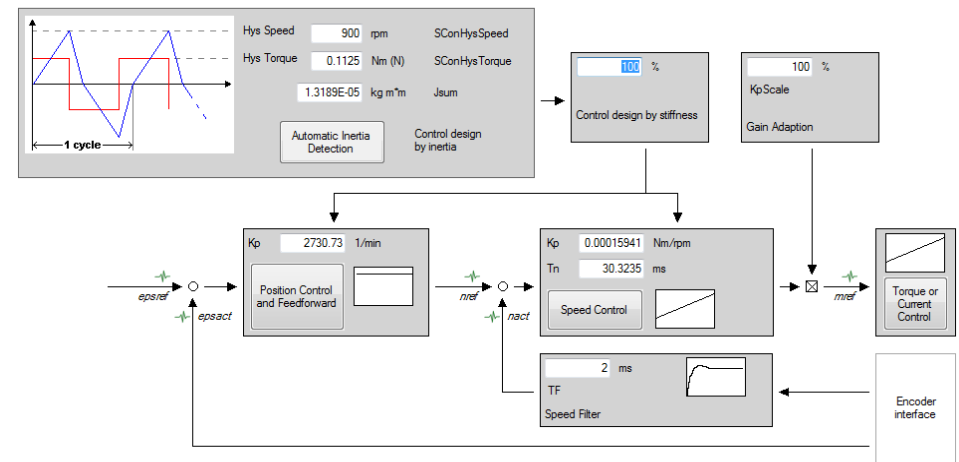

Parameter **P 0300 CON_CFG_Con** specifies the control mode with which the drive is to be run. This parameter takes effect online. Uncontrolled online switching can cause an extreme jerk, a very high speed or an overcurrent, which may cause damage to the system.

5.2.2 Adaptation of mass inertia

If the mass inertia value is not known, the wizard can be used to determine it. [Determining the mass inertia.htm](#).

**ATTENTION:**

While the mass inertia is being determined the motor shaft executes rotary movements. There is a risk that the plant and the motor may be destroyed.

5.2.3 Adaptation to the rigidity of the drive train

By setting the rigidity the settings of the speed and position control with pre-control are automatically determined. In the wizard the rigidity is indicated as a percentage. A setting < 100% reduces the dynamism of the controller setting (such as for a toothed belt drive).

A setting > 100% increases the dynamism of the controller setting (low play and elasticity). The speed controller gain is scaled separately with the percentage value of KP-Scale.

The control attenuation is influenced by way of the speed filter.

Useful settings are:

- Resolver 1-2 ms
- SinCos encoder (low-track): 0.5- 1 ms
- SinCos encoder (high-resolution): 0.2- 0.6 ms

**ATTENTION:**

After a power-off the speed and position control settings remain stored. The percentage value of the rigidity is reset to 100% however.

5.3 Determining mass inertia

To define the mass inertia of a motor easily, the "automatic mass inertia definition" function is available. In the standard motor data set the speed controller is preset for a moderately stiff mechanism.

The automatic mass inertia definition function is started when the hardware has been enabled. Clicking the "Automatic Inertia Definition" button enters the latest value obtained in SCD_Jsum.



Bild 5.3.1 Determining mass inertia



ATTENTION:

While the mass inertia is being determined the motor shaft executes rotary movements. There is a risk that the plant and the motor may be destroyed.

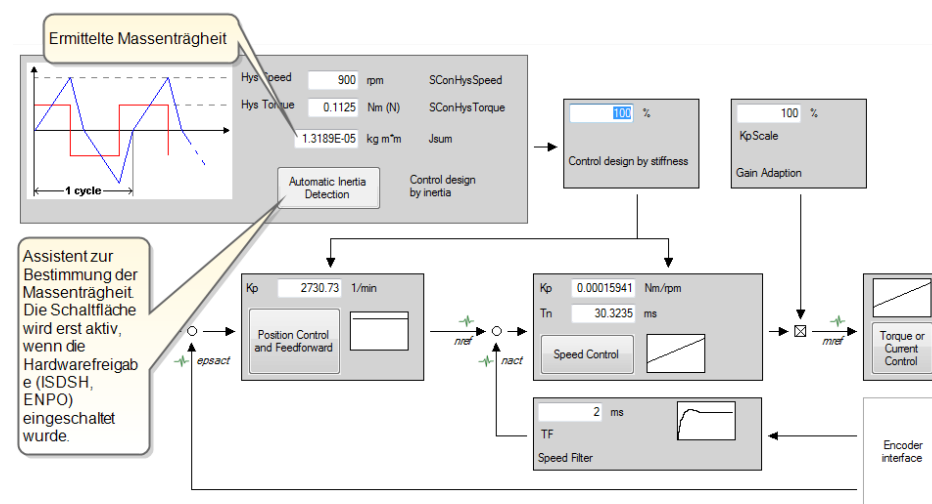

NOTE:

This function is not advisable for horizontal axes. When executing the function pay attention to mechanical limit stops. This function should only be applied with a free-rotating motor shaft.



NOTE:

If no values are entered for "Hysteresis Speed" and "Hysteresis Torque", 20% of the rated speed and 20% of the rated torque is set. The distance covered results from the preset values.

5.4 Current/torque controller settings

5.4.1 Current controller optimization

The torque controller is executed as a PI controller. The gain (P-component) and the integral-action time (I-component) of the individual controllers are

programmable.

In order to optimize the current control loop, two rectangular reference steps are preset. The object of the optimization is a current controller with moderate dynamism and the following values:

- Current control time: = 1 ms
- Overshoot: < 5%



Bild 5.4.1 Optimization of speed control

Vorgehensweise: Current controller optimization

The faster the actual value approaches the setpoint (reference), the more dynamic is the controller setting. During settling, the overshoot of the actual value should be no more than 5-10% of the reference (guide value).

- The first step (stage 1, time 1) moves the rotor to a defined position.
- The second step (stage 2, time 2) is used to optimize the torque control (step response). The level of the second step should not be selected too large, to prevent the voltage reference from going to the limit (small signal response required).
- The current and time settings automatically adjust to the motor data. The current corresponds to:

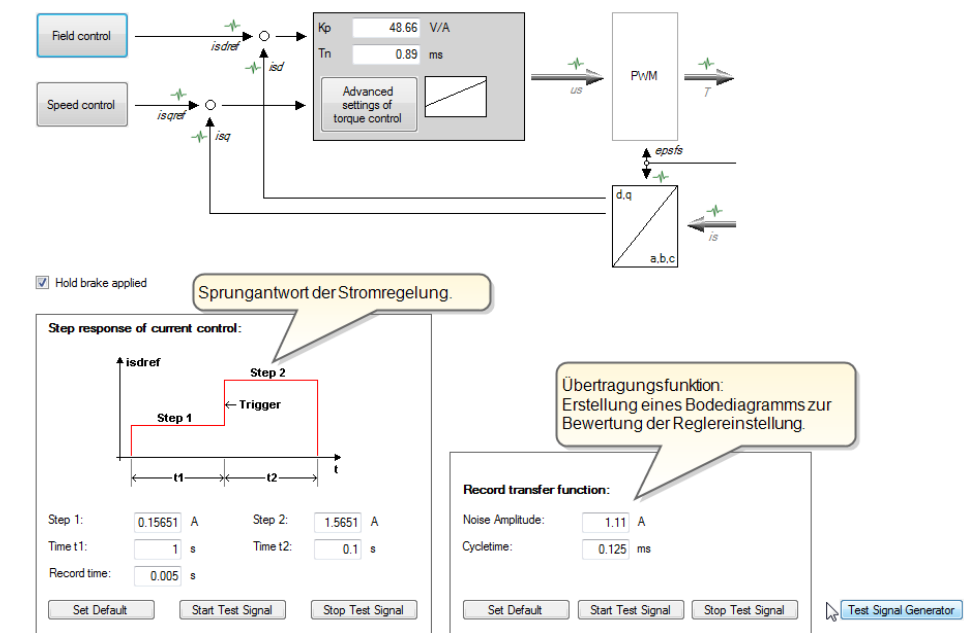
$$I_n * \sqrt{2}$$

- ISDSH and ENPO (hardware enable) must be set to "High".
- Click "Start test signal" button
- Observe the safety notice: When you confirm the safety notice a step response is executed.
- The oscilloscope is set automatically.



Bild 5.4.2 Current controller optimization

Creating the transfer function

The oscilloscope automatically records the amount and phase response of the controller according to the controller settings. This produces an initial estimate of the control quality.

To determine the transfer function the noise amplitude (motor rated current) and the sampling time (default 0.125 ms) must be specified. Click the "Start Test Signal" button.



Bild 5.4.3 Noise amplitude, sampling time



Bild 5.4.4 Current controller transfer function

1	Green curve = Amount Y-axis left = Absolute value of isd/isdref
2	Blue curve = Phase response Y-axis right = Phase response Isd / isdref

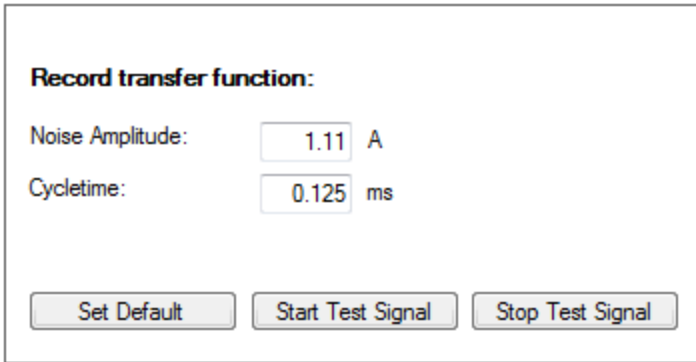
5.5 Schematic of expanded torque control

Torque control is expanded by three functions in order to optimize the control dynamics of the current and speed controllers.

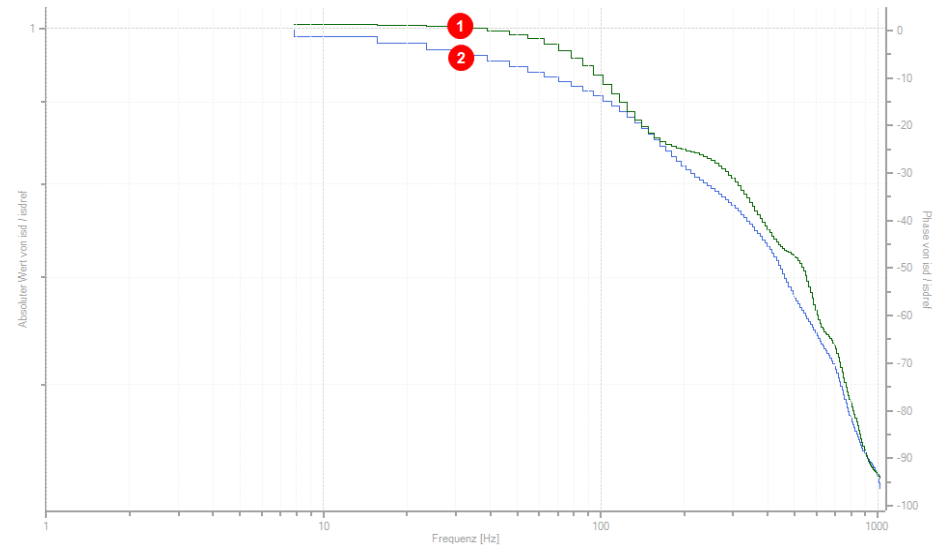
- Adaptation of torque control / Saturation characteristic: [Adaptation of torque control.htm](#)
- Observer system: [Observer.htm](#)
- Overmodulation: [Overmodulation.htm](#)





Bild 5.5.1 Schematic of expanded torque control

become unstable. In this case the gain of the current controller should be adapted to the load case by way of four interpolation points. The values for the interpolation points are entered in the dialog box as a percentage of the rated current.

On the left are the inductance values, and on the right the values for the overload (> 100% of rated current).

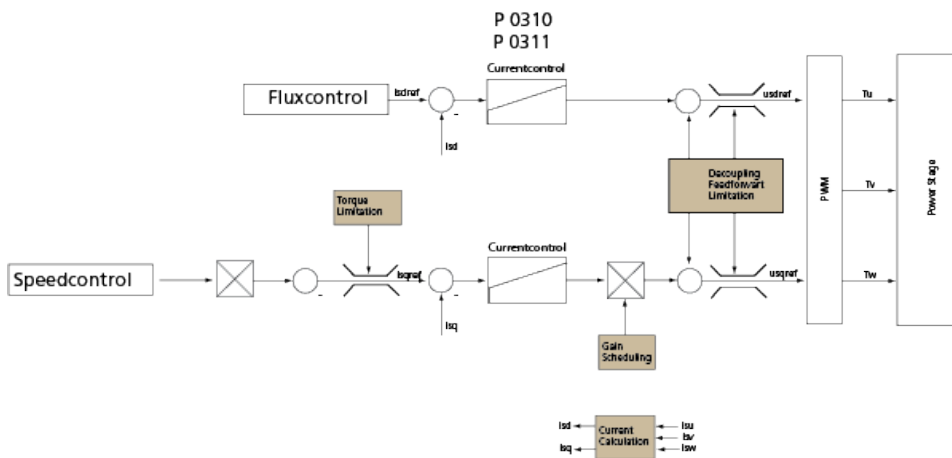
PS motor electrical parameters

Motor name: 

Pole pairs: Rated flux: Vs

Motor impedances

Stator resistance: Ohm Stator inductance: mH

Nonlinear stator inductance due to saturation of the motor

<input type="text" value="100"/> %	Stator inductance of 17.05 mH at	<input type="text" value="100"/> %	Rated current of 1.11 A
<input type="text" value="90"/> %		<input type="text" value="150"/> %	
<input type="text" value="68"/> %		<input type="text" value="200"/> %	
<input type="text" value="31"/> %		<input type="text" value="250"/> %	

Bild 5.6.1 Electrical parameters of PS motors

5.6 Adaptation of torque control

5.6.1 Saturation characteristic

In the overload range, saturation effects reduce the inductance of many motors. As a result, the current controller optimized to the rated current may oscillate or

Scaling of q-inductance "L" in [%]

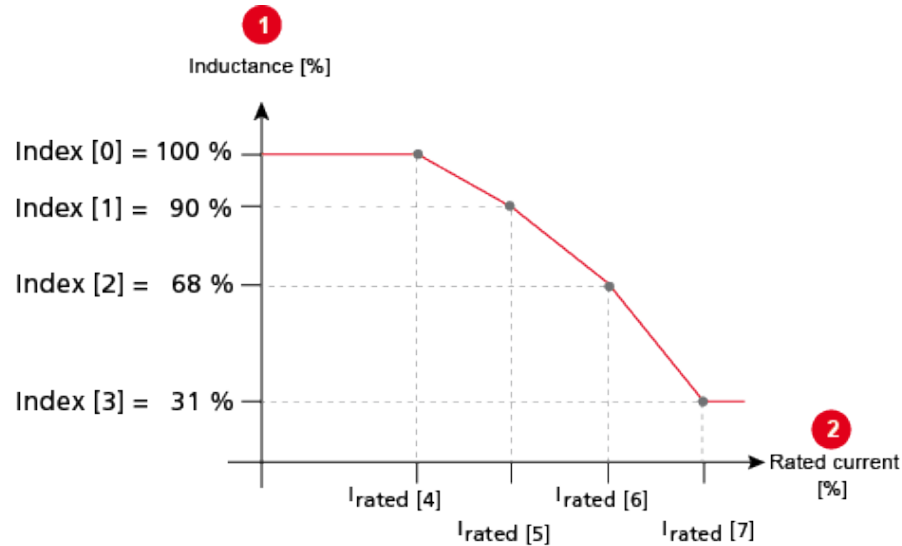

1	P 0472 (0-3) MOT_LsigDiff	Scaling of q-stator inductance in [%]; interpolation points 0 to 3.
2	P 0472 (4-7) MOT_LsigDiff	Scaling of rated current in [%]; interpolation points 4 to 7.

Bild 5.6.2 Scaling of q-inductance L in [%]

NOTE:



Between the interpolation points the scaling factor is interpolated in linear mode. The current scaling of the inductance is displayed in the scope variable "74_Is_ActVal" .

K-T characteristic

In the overload range the output-side torque is reduced due to rising losses (iron/copper losses) . This behaviour can be compensated by parameter **P 0479 MOT_TorqueSat**.

Parameters

P. no.	Parameter name	Function
P 0479	MOT_TorqueSat	Motor torque as a function of the current
(0)-(4)		Torque in [Nm]; interpolation points 0 to 4.
(5)-(9)		Current in [A]; interpolation points 5 to 9.

5.7 Observer

5.7.1 Constant dynamic based on adaptation

The speed controller must track a variable moment of inertia in order to adapt the drive controller to the machine mechanism (adaptive process). The difficulty lies in precise definition of the moment of inertia, in particular under the influence of friction, load and other non-modellable disturbances. To nevertheless optimize the

adaptation to the machine mechanism, a technique based on a state observer is available.

Contact LTi DRIVES GmbH.

Parameters

P. no.	Parameter name	Function
P 0433	CON_ CCON_ ObsMod	Switching the observer on and off for torque control
(0)	Off(0)	Observer is off
(1)	Time Const (1)	The currents determined from the observer are used for the motor control. The configuration is based on presetting of an observer time constant P 0434 CON_CCON_ObsPara, Index 0
P 0434	CON_ CCON_ ObsPara	Observation parameter
(0)	TP (0)	Observer time constant
(1)	KP (0)	Not supported
(2)	TN (2)	Not supported

Tabelle 5.7.1 Observer system

5.8 Overmodulation

5.8.1 Limitation of voltage components

The "usqref" and "usdref" components permit so-called overmodulation of the DC link voltage (limitation to hexagon instead of circle).

The maximum output voltage which can be set for each phase angle results from the circle which fits in the voltage hexagon (diagram below). By setting the hexagon modulation (3) "Hex Phase", the length of the vector for the output voltage can be placed in the area of the DC link voltage (red). As a result only two of the three half-bridges are switched in each switching interval. The third remains at the upper or lower potential of the DC link voltage for a period of 60° of the output frequency.

This method has only two third of the switching losses of modulation with all three phases. Disadvantages are higher harmonics of the motor currents and thus less smooth running at high motor speeds.

U_N = rated voltage
 U_l = voltage at inductor
 U_i = inverter voltage
 U_{zk}^u = DC link voltage
 α = phase angle

5.8.2 Hexagon modulation

Setting of the output amplitude and phase of the drive controller

Representation of the 8 vectors of the three-phase voltage system (3 half-bridges each with 2 states [2³]) The vectors correspond to the DC link voltage U_{zk} and form a voltage hexagon.



Bild 5.8.1 Circle and hexagon voltages

Parameters

P. no.	Parameter name	Function
P 0431	CON_CCON_VLimit	Voltage limit of the current controller
P 0432	CON_CCONMode	Selector for the mode of voltage limitation of "usqref" and "usdref".
(0), (1)	PRIO(0.1)	Hard switch from d-priority (motorized) to q-priority (regenerative). A portion of the voltage is held in reserve; the amount can be specified via parameter P 0431 CON_CCON_VLimit .

P. no.	Parameter name	Function
(2)	Phase(2)	Phase-correct limitation
(3)	HEX, Phase (3)	Hexagon modulation with phase-correct limitation. More voltage is available for the motor. The current exhibits a higher ripple at high voltages however (see diagram).
(4)	D_PRIO(4)	Pure priority of the d-current controller

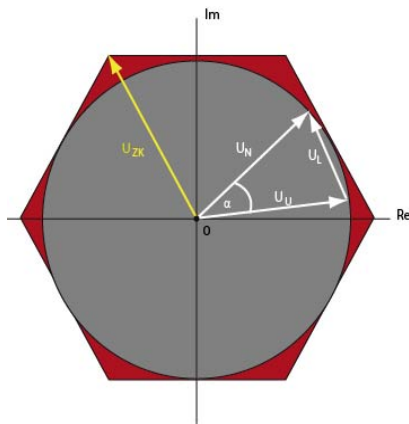
Tabelle 5.8.2 Parameters for setting the voltage limit

5.9 Torque control with defined bandwidth

The controller gain is determined by activating test signals (Autotuning). The calculations and the relevant autotuning are carried out in the drive controller. The advanced settings are made in parameters **P 1530 SCD_SetMotorControl**, **P 1531 SCD_Action_Sel** and **P 1533 SCD_AT_Bandwidth**.

- The 3dB bandwidth of the closed loop is specified as the bandwidth.
- Advisable bandwidth settings at 8 kHz switching frequency are up to approximately 2000 Hz; at 16 kHz switching frequency up to approximately 3000 Hz.
- The P-gain CCON_Kp is calculated according to the amount optimum.
- The integral-action time CCON_Tn is interpolated between the amount optimum and the symmetrical optimum (so that the I-content is sufficient, resulting in reduced interference response).

Parameters

P no.	Parameter name	Function
P1530	SCD_SetMotorControl	Torque controller setting with defined bandwidth
(-1)	Fault(-1)	Error during calculation
(0)	Ready(0)	Ready
(3)	BANDWIDTH(3)	Calculation of the torque controller parameters based on the motor data and the specified bandwidth
(4)	DEADBEAT(4)	This setting parameterizes a dead-beat controller. The structure is switched to feedback with observer, the observer is designed (to a specific equivalent time constant – for setting see P 0434(0) CON_CCON_ObsPara – and the speed controller gains are calculated accordingly.
P1531	SCD_Action_Sel	Start conditions to determine the torque controller settings
(-1)	FAULT (-1)	Function set in P 1530 SCD_SetMotorControl stops with an error message
(0)	READY(0)	Ready
(6)	BANDWIDTH(6)	Optimization of torque controller gain with band-pass: TuneCCon Activation of sinusoidal test signals and adaptation of the current controller parameters based on the specified bandwidth

P no.	Parameter name	Function
P1533	SCD_AT_Bandwidth	Bandwidth preset for torque control loop: Setting range: 10 - 4000 Hz

Tabelle 5.9.1 Definition of bandwidth

5.10 Detent torque compensation

In order to compensate for detent torques (caused by non-sinusoidal EM curves), the torque-forming q-current is entered in a table and "taught-in". After elimination of the offsets (compensated table), the q-current is inverted and fed-in as the pre-control value of the control. The compensation function can be described by means of compensating currents (q-current, scope signal "isqref_comp") dependent on a position (electrical angle, scope signal "epsRS"). A "teach-in" is used to import the values into a table. With parameter **P 0382 CON_TCoggComp** the method to be used is selected:

- OFF(0), switched off
- **EPSRS(1)**, compensation referred to electrical angle (250 values).
- **ABSPOS(2)**, compensation referred to a freely definable position (4000 values).
- **EPMS(3)**, compensation referred to one mechanical revolution (250 values).

The interpolation between the table values is linear. The characteristic is not saved automatically; it must be saved manually. The progress of the teach

process and the compensation can be tracked on the scope. The signal **55_ isqCoggingTeach** indicates the momentary output value of the teach table during teach mode, while **56_ isqCoggingAdapt** contains the momentary value from the compensation table.

Vorgehensweise: Populate table (teach EPSRS)

- Open manual mode window
- Speed control setting (set high rigidity, for smooth running)
- Set parameter **P 0385 CON_TCoggTeachCon** to "TeachTab(1)" for EPSRS.
- Start control
- Run motor at low speed (approx. 1 rpm), wait at least one motor revolution.
- Set parameter **P 0385 CON_TCoggTeachCon** to "CalCorrTab(3)" for EPSRS. This imports all values into the compensation table **P 0380 CON_Add Tab**.
- Stop control
- With **P0382 CON_TCoggComp = (1)EPSRS** activate the process.
- Save device data

Vorgehensweise: Populate table (teach ABSPOS)

- Open manual mode window
- Speed control setting (set high rigidity, for smooth running)
- Set parameter **P 0385 CON_TCoggTeachCon** to "TeachTab(2)" for ABSPOS.
- Parameter **P 0442 CON_TAB_PosStart**: Define start position
- Parameter **P 0443 CON_TAB_PosDelta**: Define position delta: **Start position + (position delta * 4000) = end position**
- Parameter **P 0445 CON_TAB_TeachDir**: Define direction of rotation: (pos-/neg-/both-direction)
- Start control
- Move the motor at low speed (approx. 1 rpm) until parameter **P 0440 CON_TAB_TabIndex** > 4000 (table ABSPOS is not visible).
- Set parameter **P 0385 CON_TCoggTeachCon** to COMPTab(5) for ABSPOS. This imports all values into the compensation table.

- Stop control
- With **P0382 CON_TCoggComp = (2)ABSPOS** activate the process.
- Save device data

Vorgehensweise: Teach-in (teach EPMS)

- Open manual mode window
- Speed control setting (set high rigidity, for smooth running)
- Set parameter **P 0385 CON_TCoggTeachCon** to "TeachTab(6)" for TeachEPMS.
- Start control
- Run motor at low speed (approx. 1 rpm), wait several motor revolutions.
- Set parameter **P 0385 CON_TCoggTeachCon** to "CalCorrTab(3)". This imports all values into the compensation table **P 0380 CON_Add Tab**.
- Stop control
- With **P0382 CON_TCoggComp = (3)EPMS** activate the process.
- Save device data

Parameters

P. no.	Parameter name	Function
P 0380	CON_TCoggAddTab	Taught-in values (EPSRS)
P 0382	CON_	Selection of process

P. no.	Parameter name	Function
	TCoggComp	
(1)	EPSRS	Compensation referred to the electrical angle; example – three-pole pair motor: The table in P 0380 CON_TCoggAddTab is populated three times within one mechanical motor revolution. The compensation is effected with the averaged table values.
(2)	ABSPOS	Compensation referred to a freely definable position.
(3)	EPMS	Compensation referred to one mechanical revolution
(4)	ENCPOS	Compensation referred to one revolution of the encoder
P 0385	CON_TCoggTeachCon	Selection of teach function
(1)	TeachTab(1)	Activation of Teach function EPSRS
(2)	TeachTab(2)	Activation of Teach function APSPPOS
(3)	CalcCorTab(3)	Calculation of compensation
(4)	RESET(4)	Reset table values
(5)	COMPTAB(5)	Calculation of compensation APSPPOS
P 0440	CON_TAB_TabIndex	Compensation table: Index
P 0441	CON_TAB_TabVal	Compensation table: Actual

P. no.	Parameter name	Function
P 0442	CON_TAB_PosStart	Compensation table: Start position
P 0443	CON_TAB_PosDelta	Compensation table: Position delta
P 0445	CON_TAB_TeachDir	Compensation table: Direction of rotation Teach mode
P 0446	CON_TAB_OutVal	Compensation table: Output value

Tabelle 5.10.1 Detent torque compensation

5.11 Test signal generator (TG)

5.11.1 Optimization of control loops with the TG

It is possible to form various signal types and transfer them to the control. This function is independent of the control mode, and acts directly on the control. Signal types can also be combined.

The delta signal form is additionally available, though at present it is only accessible via the parameter editor. The parameters are recorded in the parameter list.

5.11.2 PRBS signal

The PRBS signal is suitable to achieve a system excitation with a high bandwidth by using a test signal. A binary output sequence with parameterizable amplitude

P 1509 SCD_TSIG_RBSAmp and a "random" alternating frequency is generated with the aid of a looped-back shift register.

Step 1: var

Step 2: var

Time t1: s

Time t2: s

Number of cycles N:

Amplitude a: var

Frequency f: Hz

Amplitude 2 * a: var

Cycletime T(PRBS): ms

Output Signal Selection: ISDREF(1) = d-current reference

Duration of testsignal = N*(t1 + t2): 1.1 s

Start Stop

Bild 5.11.1 Dialog box for setting the test signal generator



Bild 5.11.2 TSIG output: Signal curve of TG



Bild 5.11.3 Test signal generator for square signal

1

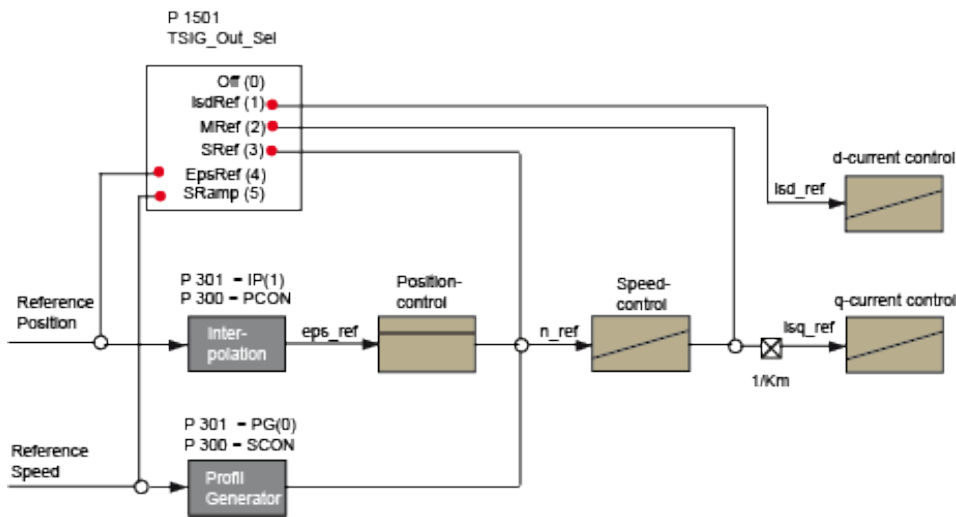
Square signal setting:
 Stage 1 = +1000 rpm
 Stage 2 = -1000 rpm
 t1 = 1 s

Signal setting parameters

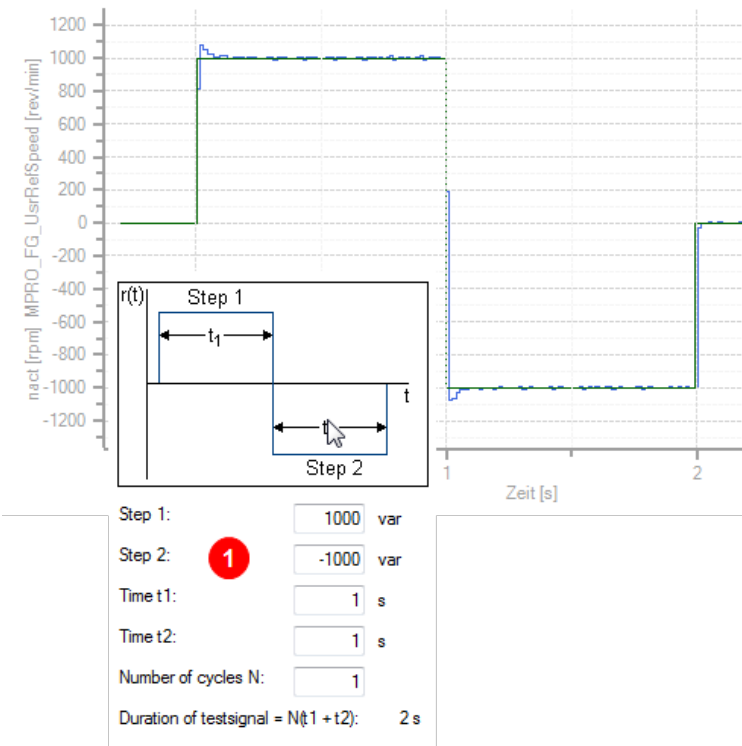
P. no.	Parameter Setting	Function	Info
P1500	SCD_TSIG_Con	Control word of test signal generator	The parameter is reset to the value 0 on completion of the stop procedure.
(0)	OFF	Test signal generator deactivated	
(1)	Stop	Stop test signal	
(2)	Start	Start test signal	
(3)	STOP-Cycle	TG stops at end of current square cycle	
(4)	Stop-Zero	TG stops next time reference value passes through zero	
P1501	SCD_TSIG_OutSel	Test signal generator output selector	
(0)	OFF	Not used	
(1)	isdref	Flux-forming current	
(2)	mref	Torque	
(3)	sref	Speed	
(4)	epsref	Position	
(5)	sramp	Speed (ramp)	

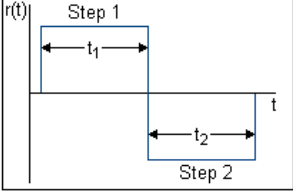
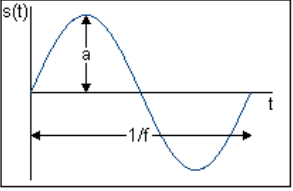
P. no.	Parameter Setting	Function	Info
P1502	SCD_TSIG_Cycles	Number of repeat cycles	 <p>Stufe 1: <input type="text" value="1000"/> var Stufe 2: <input type="text" value="-1000"/> var Zeit t1: <input type="text" value="1"/> s Zeit t2: <input type="text" value="1"/> s Anzahl der Durchläufe N: <input type="text" value="1"/> Dauer des Testsignals = N(t1 + t2): 2 s</p>
P1503	SCD_TSIG_Offset	Offset of square signal	
(0)		Offset of square signal stage 1	
(1)		Offset of square signal stage 2	
P1504	SCD_TSIG_Time	Period of square signal	
(0)		Time t1	
(1)		Time t2	
P1505	SCD_TSIG_Amp	Amplitude of sine signal	 <p>Amplitude a: <input type="text" value="50"/> var Frequenz f: <input type="text" value="1"/> Hz</p>
P1506	SCD_TSIG_Freq	Frequency of sine signal	
P1507	SCD_TSIG_SetPhase	Phase angle of signal: Start phase of current space vector	

P. no.	Parameter Setting	Function	Info
		in VFCON and ICON mode	
P1508	SCD_TSIG_PRBSTime	PRBS signal generator, sampling time	
P1509	SCD_TSIG_PRBSAmp	PRBS signal generator, amplitude	Amplitude $2 \cdot a$: <input type="text" value="150"/> var Zykluszeit T(PRBS): <input type="text" value="20"/> ms
P1510	SCD_TSIG_SignalType	Signal shape: Sine/delta	
P1511	SCD_TSIG_BreakTime	Break time	
(0)	SCD_TSIG_BreakTime	Break (ms) before signal cycle	
(1)	SCD_TSIG_BreakTime	Break (ms) between positive and negative signal cycle segment	
P1512	SCD_TSIG_SymVal	Symmetry value for delta signal	

Tabelle 5.11.4 Parameters of test signal generator for square and sine signal

Example of a PRBS signal

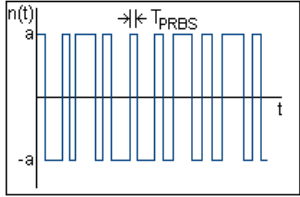
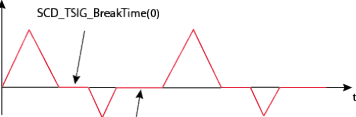
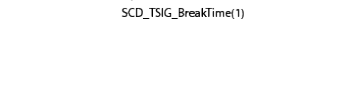

Bild 5.11.5 PRBS signal

5.12 Optimizing the speed controller

Speed controller setup dialog box

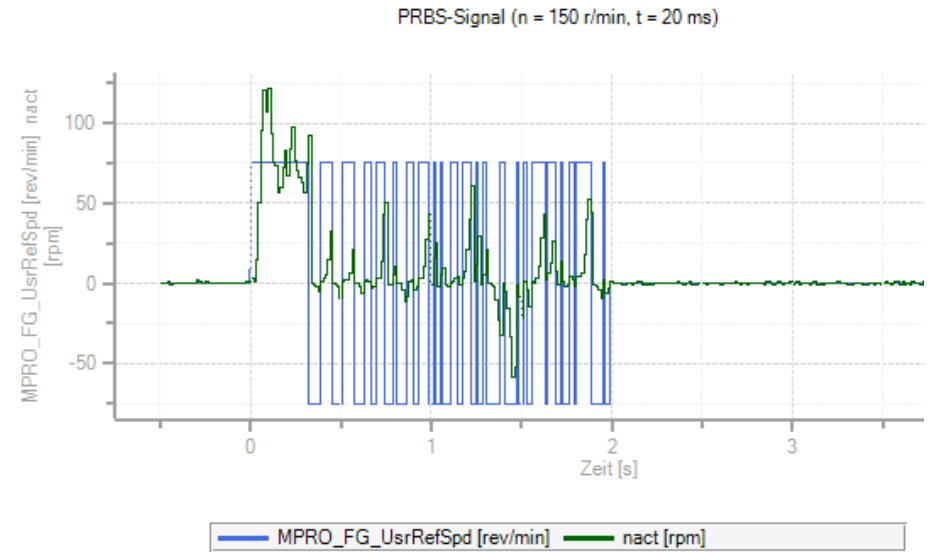

Bild 5.12.1 Speed controller setup dialog box

1	Gain (KP)
2	Integral-action time (I)
3	Scaling factor for gain
4	With these filters it is possible to filter noise in the actual speed value and increase the attenuation of resonance frequencies.

5	Advanced speed control (observer).htm
6	Analysis of speed control.htm
7	Actual speed filter

Tabelle 5.12.2 Function description of speed controller dialog box

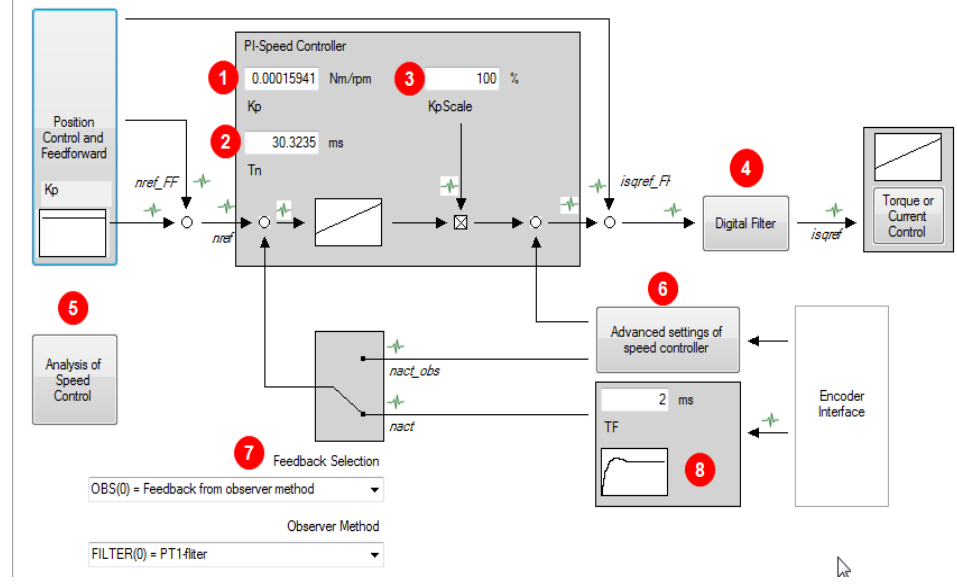
Adaptation of parameters

Acceleration and braking phases generate a variation which the speed control has to balance out. With speed pre-control the necessary acceleration or braking moment determined from the change in speed over time is applied to the output of the speed controller.

If the travel range is not limited, it is advisable to optimize the speed controller by means of step responses. In this, the motor model must be adapted precisely to the individual motor. In the standard motor data set the speed controller is preset for a moderately stiff mechanism. The speed controller may still need to be adapted to the moment of inertia and the rigidity of the mechanical system. All parameters take effect online. The scaling parameter

P 0322 CON_SCON_KpScale is transferred in defined real time (according to the speed controller sampling time).

The following steps are needed to set the speed control loop depending on the application:

- Adapt the speed controller gain to the existing external mass inertia. For this, either the known moment of inertia from the motor data can be used directly or the automatic mass inertia definition function in the Motor Identification subject area can be used.
- If the system's moment of inertia is defined manually, it must be reduced to the motor.

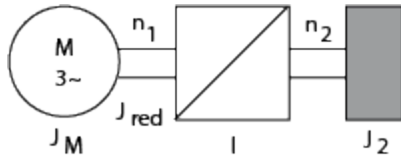

$$J_{red} = \frac{J_2}{i^2} = \frac{J_2}{\left(\frac{n_1}{n_2}\right)^2}$$

J_M = Moment of inertia of motor

J_{red} = Reduced moment of inertia of system

i = Gear transmission ratio factor

Reduced moment of inertia

5.13 Analysis of speed control

The speed controller is executed as a PI controller. The gain (P-component) and the integral-action time (I-component) of the individual controllers are programmable.

In order to optimize the speed control loop, two rectangular reference steps are preset.

For automatic controller optimization the step response and transfer function wizards are available.

Bild 5.13.1 Advanced analysis of the speed controller

Vorgehensweise: Optimizing the speed controller

- The speed and time settings are generated automatically from the motor data.
- ISDSH and ENPO (hardware enable) must be set to "High".
- Click "Start test signal" button
- Observe the safety notice: When you confirm the safety notice a step response is executed.
- The oscilloscope is set automatically.
- The faster the actual value approaches the setpoint (reference), the more dynamic is the controller setting. During settling, the overshoot of the actual value should be no more than 5-10% of the reference (guide value).



Bild 5.13.2 Step response to rated speed

Creating the transfer function

The oscilloscope automatically records the amount and phase response of the controller according to the controller settings. This produces an initial estimate of the control quality. To determine the transfer function the noise amplitude (motor rated current) and the sampling time (default 0.125 ms) must be specified. Click the "Start Test Signal" button.

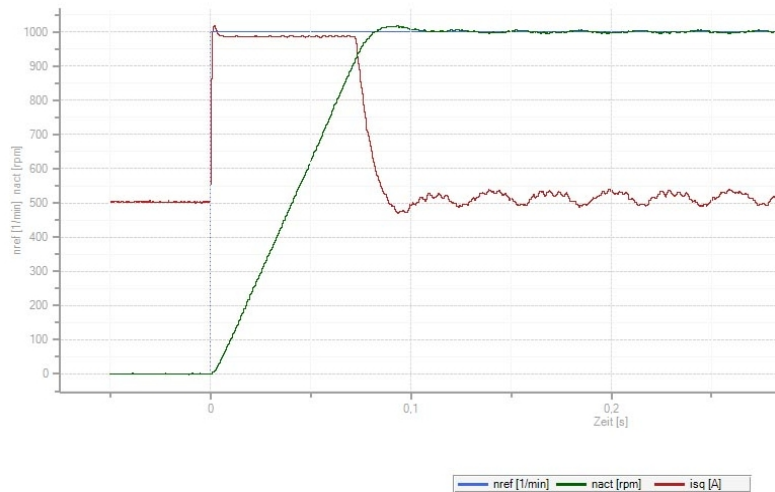

Bild 5.13.3 Noise amplitude, sampling time



1	Green curve = Amount Y-axis left = Absolute value of nact/ndiff
2	Blue curve = Phase response Y-axis right = Phase response nact/ndiff

Bild 5.13.4 Speed controller transfer function

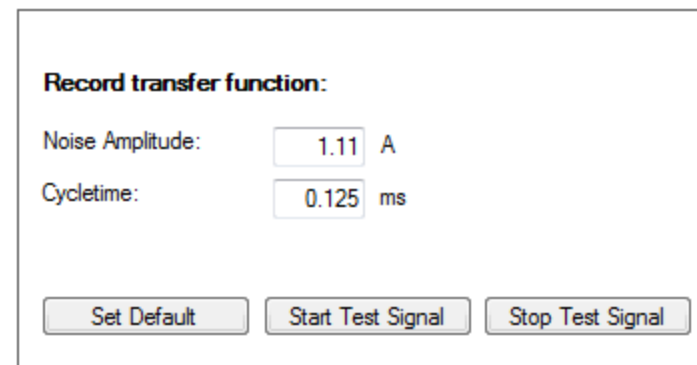
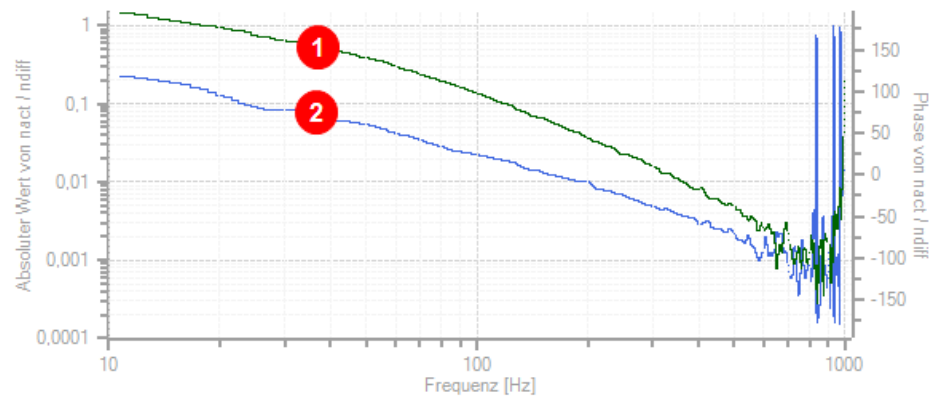
Back
Digital filter settings of speed controller

Select Filter: NOTCH_NOTCH(3) = 1.filter=notch, 2.filter=notch

1. Filter

center / cut off (f1) Hz

width (w1) Hz

2. Filter

center / cut off (f2) Hz

width (w2) Hz

Coefficients

b0 * x(k)	<input style="width: 80%;" type="text" value="0.97435"/>	
b1 * x(k-1)	<input style="width: 80%;" type="text" value="-3.38339"/>	a1 * x(k-1) <input style="width: 80%;" type="text" value="-3.42811"/>
b2 * x(k-2)	<input style="width: 80%;" type="text" value="4.86219"/>	a2 * x(k-2) <input style="width: 80%;" type="text" value="4.86186"/>
b2 * x(k-3)	<input style="width: 80%;" type="text" value="-3.38339"/>	a3 * x(k-3) <input style="width: 80%;" type="text" value="-3.33868"/>
b4 * x(k-4)	<input style="width: 80%;" type="text" value="0.97435"/>	a4 * x(k-4) <input style="width: 80%;" type="text" value="0.94902"/>

Bild 5.14.1 Selection of various digital filters

5.14 Digital filters

5.14.1 Setting of filter combinations

To filter any noise on the actual speed value, or to damp resonance frequencies, various filter combinations can be used. A range of filter variants are available. The coefficients of the transfer function are automatically determined as soon as the values for the middle and limit frequency and the width have been entered.



Bild 5.14.2 Bode diagrams PT1 to PT4

Parameters

P. no.	Parameter name	Function
P 0325	CON_ SCON_ FilterFreq	Limit frequencies
(0)	1 - 8000 Hz	Middle, limit frequency
(1)	1 - 8000 Hz	Width
(2)	1 - 8000 Hz	Middle, limit frequency
(3)	1 - 8000 Hz	Width
P 0326	CON_ SCON_ FilterAssi	Filter selector
(0)	Off	No filter active

P. no.	Parameter name	Function
(1)	USER	Manual writing of filter coefficients
(2)	Notch	Selection of a notch filter with the limit frequency from P 0325(0) CON_SCON_FilterFreq and the bandwidth from P 0325(1) .
(3)	Notch_ Notch	Selection of a notch filter with the limit frequency from P 0325(0) and bandwidth from P 0325(1) in series with a notch filter with the limit frequency from P 0325(2) and bandwidth from P 0325(3)
(4)	Notch_PT1	NOTCH_PT1(4) and NOTCH_PT2(5): A notch filter with the blocking frequency in P 0325(0) and bandwidth in P 0325(1) in series with a low-pass filter with limit frequency in P 0325(2) .
(5)	Notch_PT2	
(6)	PT1	PT1(6), PT2(7), PT3(8), PT4(9): A low-pass filter with the limit frequency in P 0325(2) At lower frequencies higher-order filters (PT3, PT4) should not be used.
(7)	PT2	
(8)	PT3	
(9)	PT4	
P 0327	CON_ SCON_ FilterPara	Coefficients of the digital filter

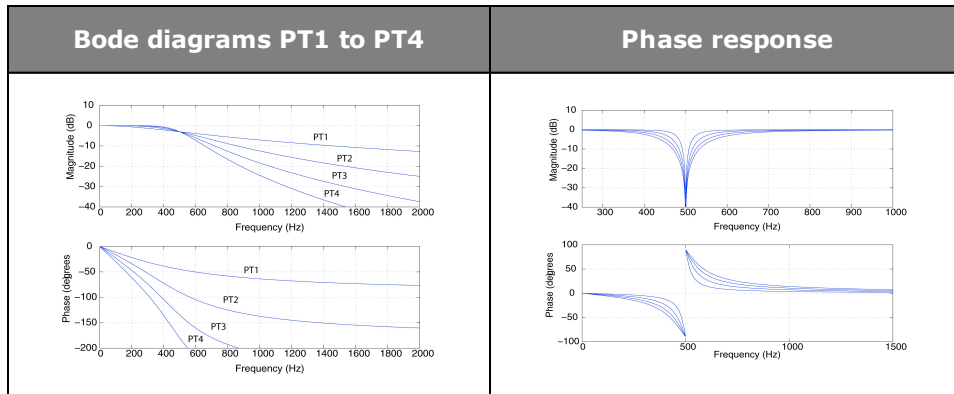
P. no.	Parameter name	Function
(0)	b0	Filter coefficients
(1)	b1	
(2)	b2	
(3)	b3	
(4)	b4	
(5)	a1	
(6)	a2	
(7)	a3	
(8)	a4	

Tabelle 5.14.3 Parameters to set the filter constants

- Create scope plot with notch filtering



Tabelle 5.14.4 FFT transformation

Vorgehensweise: FFT signal analysis

- Scope setting:
isq (unfiltered, torque-forming current) Set shortest sampling time Create scope plot without notch filtering
- On the oscilloscope click the "Mathematical functions" > FFT (Fourier analysis) icon. From the following pop-up menu choose isq. Disturbance frequency is displayed.
- "Select filter": Select filter
- Enter middle/limit frequency
- Width: Enter the bandwidth of the limit frequency; the width has no effect when using PTx filters

NOTE:

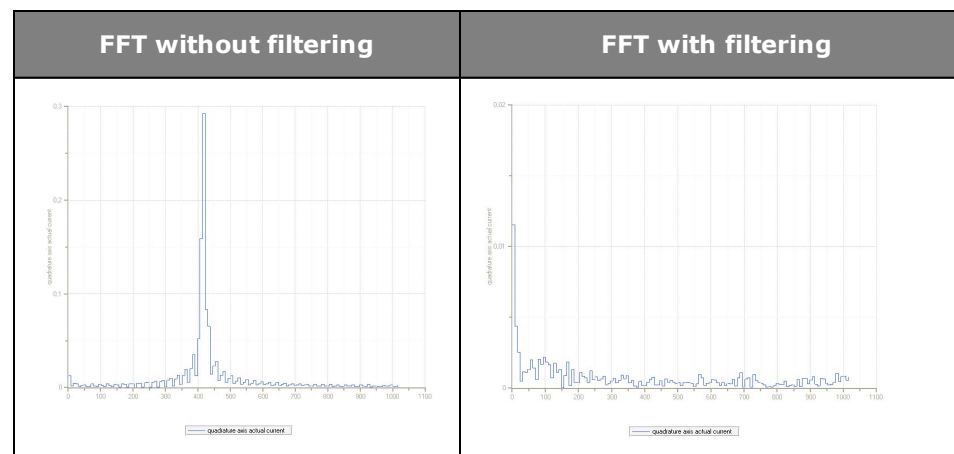
Note that the filters not only have an effect on the amount but also on the phase of the frequency response. At lower frequencies higher-order filters (PT3, PT4) should not be used, as the phase within the control bandwidth is negatively influenced.

The coefficients can also be specified directly via parameter **P 0327 CON_SCON_FilterPara**. They take effect directly, so changing



them is only recommended when the control is switched off.

**NOTE:**

A large bandwidth results in less attenuation of the limit frequency.

**NOTE:**

To use this function, contact LTI DRIVES GmbH.

5.15 Advanced speed control (observer)

The phase shifts over time in the feedback branch generate high-frequency noise as well as high-frequency resonances.

The single-mass observer reduces these high-frequency interference and increases the control dynamism.

The function of the observer is based on the mathematical description of the controlled system which calculates the trend over time of the state variables under the influence of the input variables. The difference between the measured and estimated state variables is fed back to the estimated state variables by way of a feedback matrix, parameter **P 0353(1) "Observer time constant"**. The aim is to equalize the estimated state variables as quickly as possible to the measured variables.

5.16 Reduktion der Geschwindigkeitsverstärkung

5.16.1 Reduktion bei kleinen Geschwindigkeiten

Bei sehr dynamisch eingestelltem Geschwindigkeitsregler kann es bei kleinen Geschwindigkeiten oder Geschwindigkeit Null zu unerwünschten Schwingungen des Geschwindigkeitsreglers kommen. Durch eine geeignete Einstellung des Parameters **P 0336 CON_SCON_KpScaleSpeedZero** wird die Schwingneigung reduziert.



Bild 5.16.1 Reduktion der Geschwindigkeitsverstärkung bei kleinen Geschwindigkeiten

Parameter

P-Nr.	Parameter-einstellung	Funktion
P 0336	CON_SCON_ KpScaleSpeedZero	Reduktion der Geschwindigkeitsverstärkung bei kleinen Geschwindigkeiten oder Geschwindigkeit 0. Zur Vermeidung von Schwingungen. Der eingestellte Wirkungsbereich gilt für positive und negative Geschwindigkeiten.
(0)		Wichtung der Reduktion der Geschwindigkeitsreglerverstärkung (1 = 100%)
(1)		Wirkungsbereich der Reduktion: Geschwindigkeitsgrenze für "Geschwindigkeit Null erreicht" (Stillstandsfenster).
(2)		Filterzeit für den Geschwindigkeitsübergang von 0 nach n_{max}
(3)		Filterzeit für den Geschwindigkeitsübergang von n_{max} nach 0

Tabelle 5.16.2 Einstellungsparameter für die Reduktion

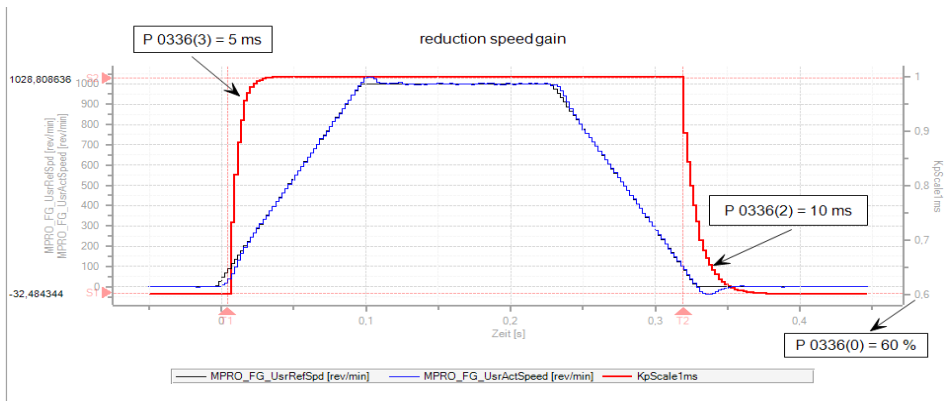
5.17 Sensorless quick-stop

Response to wire break

In the event of a wire break on the encoder system the drive is shut down in sensorless mode on the preset quick-stop ramp. Due to the lack of dynamism at low speeds, the sensorless control is very "imprecise". To enable the drive

nevertheless to be run down smoothly to speed 0, as from the speed threshold parameterized in **P 0355(0)** the controller switches to a current/frequency (IF) control. For stabilization, an additional parameterizable d-current must be injected via **P 0355(1)**. The speed controller gain is reduced by the factor **P 0355(2)**.



Bild 5.17.1 Sensorless quick-stop

Parameters

P no.	Parameter name	Function
P 0355	CON_SCALC_SensorlessStop	Configuration of sensorless quick-stop
(0)	LowSpeedLimit(0)	Speed threshold

P no.	Parameter name	Function
(1)	d-current IF control	Additive d-current
(2)	SpeedControlGainScale	Scaling of speed gain
P 0030	ErrorReactions	Error reaction
(35)	Reac_EncObs	Error 35 Wire break detection on encoder
P2242	MPRO_402_QuickStopDec	Quick-stop ramp

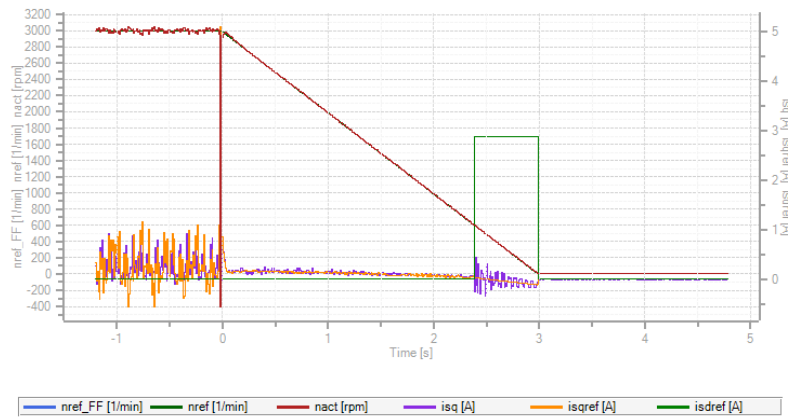
Tabelle 5.17.2 Setting for sensorless quick-stop

5.18 Position controller setup

The higher the dynamism of the speed controller, the more dynamically the position controller can be set and the tracking error minimized. The variables for the pre-control of the speed and position controller are additionally determined either from the change in reference values or alternatively are already calculated and outputted by the motion control. The time-related values for the position, speed and torque are transmitted to the drive control.

If the dynamic change in these values is within the limits which the drive is able to follow dynamically, the load on the controllers is significantly reduced. In order to improve the dynamism of the position controller, the following dialog box is provided to optimize the speed and acceleration pre-control.

Filters and scaling



Bild 5.18.1 Pre-control dialog box

No.	Function
1	Delay time and scaling for torque pre-control
2	Delay time and scaling for speed pre-control
3	Delay time for position pre-control
4	Scaling of friction torque

Tabelle 5.18.2 Legend to pre-control dialog box

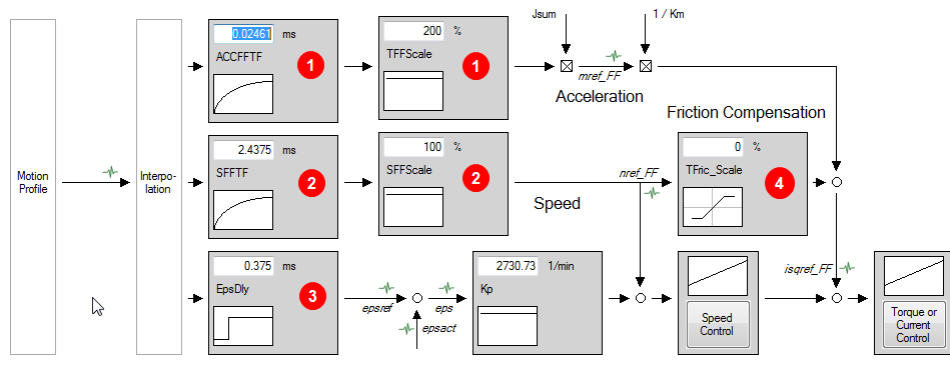

NOTE:

When a standard motor data set is read-in, the position controller gain is also adopted. The setting equates to a controller with a medium rigidity. In the default setting no smoothing is selected!

5.18.1 Position controller pre-control

The pre-control of the acceleration torque relieves the strain on the speed controller and optimizes the control response of the drive. To pre-control the acceleration torque, the mass inertia reduced to the motor shaft must be known. If the parameter for the overall mass inertia of the system **P 1516 SCD_Jsum** has a value $\neq 0$, that value will be automatically used to pre-control the acceleration torque.

The pre-control of the speed reference is preset by default to 100% via parameter **P 0375 CON_IP_SFF_Scale**. This value should not be changed.

The acceleration torque pre-control can be optimized with **P 0376 CON_IP_TFF_Scale**. Reducing this reduces the pre-control value; conversely, increasing this value also increases the pre-control value. The position tracking error can be further reduced by predictive torque and speed pre-control – that is, in advance of the position reference setting. Owing to the time-discrete mode of operation of the control circuits and the limited dynamism of the current control circuit, this prediction is necessary to prevent the individual control circuits from oscillating against one another. Prediction in pre-control is achieved by retarding the references for speed and position controllers.

Parameters for setting the pre-control

P. no.	Parameter name	Function
P 0360	CON_PCON_KP	Position controller gain
P 0372	CON_IP_SFFTF	Prediction (delay time) for speed controller pre-control
P 0374	CON_IP_EpsDly	Prediction (delay time) for position controller pre-control
P 0375	CON_IP_SFFScale	Speed controller pre-control scaling factor
P 0376	CON_IP_TFFScale	Torque controller pre-control scaling factor
P 0378	CON_IP_ACC_FFTF	Prediction (delay time) for torque controller pre-control
P 0386	CON_SCON_TFric	Scaling factor for friction compensation Friction torque compensation.htm
P1516	SCD_Jsum	Reduced mass inertia

Tabelle 5.18.1 Parameters for setting the pre-control

axis coordination, such as in the case of machine tools, the delay of the position signal must be equally set on all axes via parameter **P 0374-IP_EpsDly**. Otherwise the synchronization of the axes may suffer, leading to three-dimensional path errors.

5.19 Friction torque compensation

Compensation of friction components dependent on reference speed

It is advisable to compensate for higher friction torques, in order to minimize tracking error when reversing the speed of the axle. The drive controller enables compensation of friction components dependent on the reference speed "nref_FF". The speed controller can compensate for viscous friction components because of their lower change dynamism. The compensation can be effected step-by-step as a percentage of the rated motor torque by means of **P 0386 CON_SCON_TFric**. Below **P 0387 CON_SCON_TFricZeroSpeed** the compensation is reduced by way of an internal ramp.

ATTENTION:



- When using linear interpolation torque pre-control is inactive.
- The overall moment of inertia in **P 1516 SCD_Jsum** must not be changed to optimize the pre-control, because this would also have an effect on other controller settings!
- In multi-axis applications requiring precise three-dimensional



Bild 5.19.1 Friction curve with high static friction

Parameters for representation of the curve:

No.	P. no.	rpm
1	P 0387 CON_SCON_TFricSpeed (0)	5 rpm
2	P 0387 CON_SCON_TFricSpeed (1)	35 rpm
3	P 0387 CON_SCON_TFricSpeed (2)	200 rpm
4	P 0386 CON_SCON_TFric (0)	20%
5	P 0386 CON_SCON_TFric (1)	-10%
6	P 0386 CON_SCON_TFric (2)	15%

Tabelle 5.19.2 Parameters for representation of the curve

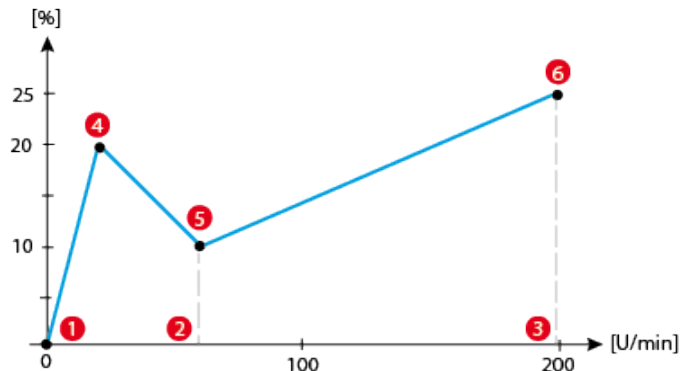
Vorgehensweise: Friction torque compensation

- Execute a fast movement
- Friction torque compensation via **P 0386(0), (1), (2)** "Friction torque compensation, scaled to the motor rated torque"
- Standstill window via **P 0387(0), (1), (2)** "Friction torque compensation, speed limitation"
- Observe tracking error

Scope setting:

- Pre-control:
 - Reference torque with pre-control `mref_FF`
 - Actual torque `mact` or
 - Reference current `isqref_FF`
 - Actual current `isq`
- Tracking error
 - `MPRO_FG_UsrPosDiff`

5.20 ASM field-weakening

Up to rated speed the asynchronous motor runs with a full magnetic field and so is able to develop a high torque. Above rated speed the magnetic field is reduced because the maximum output voltage of the inverter has been reached and the motor is run in the so-called field-weakening range with reduced torque.

For field-weakening of asynchronous motors, the motor parameters must be known very precisely. This applies in particular to the dependency of the main inductance on the magnetizing current. It is essential to carry out a motor identification and an optimization in the basic setting range for field-weakening mode. In the process, default values for the control circuits and the "magnetic operating point" are set based on the rated motor data and the magnetizing current presetting in **P 0340 CON_FM_Imag**. Two variants are available for operation in field-weakening mode.

There are two variants for field-weakening of an asynchronous motor. The choice of variant 1 or 2 is made via parameter **P 0435 CON_FM_FWMode**.



Bild 5.20.1 Field weakening

1 Variant 1: (Table)

Combination of "pre-control via 1/n characteristic" + voltage controller. The motor identification sets the voltage controller so that the voltage supply in a weakened field is adequate. If the drive controller is at the voltage limit, it reduces the d-current and thus the rotor flux. Since the controller has only limited dynamism, and starts to oscillate if larger gain factors are set, it is possible to use variant 2.

2 Variant 2: (Calc)

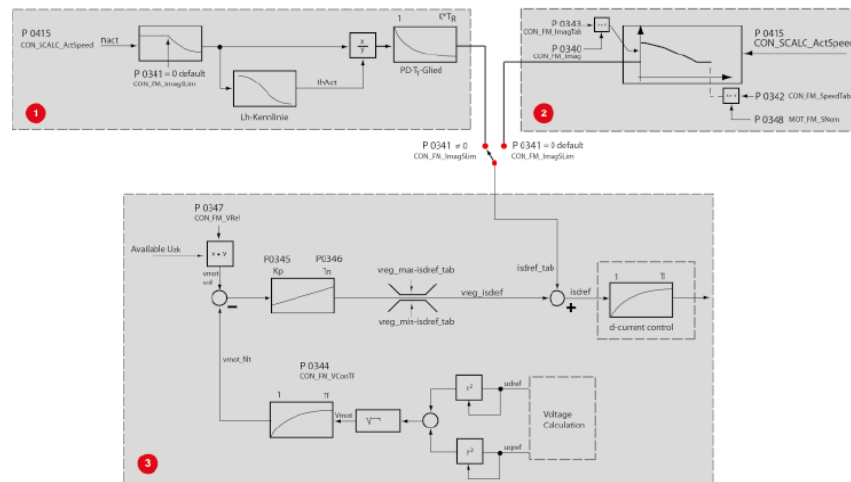
Combination of "pre-control with modified 1/n characteristic (isd=f(n)) + voltage controller.

This characteristic describes the magnetizing current as a percentage of the nominal value of

P 0340 CON_FM_Imag dependent on the speed.

The choice between the modified 1/n characteristic and the static characteristic is based on parameter **P 0341 CON_FM_ImagSLim**.

P 0341 ≠ 0 signifies selection of the 1/n characteristic (default)

P 0341 = 0 signifies selection of the modified 1/n characteristic $isd = f(n)$.

After a motor identification the voltage controller is always active, as the controller parameters are preset. With **P 0345 CON_FNVConKp = 0** the voltage controller is deactivated.

Parameterizing variant 2:

Setting the d-current dependent on the speed. The speed is specified relative to the rated speed in **P 0458 MOT_SNom**, the d-current relative to the magnetizing current in parameter **P 0340**. Up to the field-weakening speed, a constant magnetizing current is injected

P 0340.

3 Voltage controller:

Vorgehensweise: Selection of modified characteristic

- **P 0341 = 0** (selection of modified characteristic) + voltage controller
- Approach desired speeds slowly
- Adjust scope: Isdref
- $\text{SQRT2} \cdot I_{\text{mag}} = \%$ -speed value
- The maximum amount of the "field-forming" d-current is defined by parameter **P 0340 CON_FM_Imag** (specification of effective value).
- Enter values in table; **P 0342 CON_FM_SpeedTab**

Example:

Index	P 0348 rated speed P 0340 $I_{\text{mag eff}}$	P 0342 (0-7) Field-weakening speed in [%]	P 0343 (0-7) Magnetizing current in field-weakening mode in [%]
(0)	$I_{\text{rated}} = 1800 \text{ rpm}$ $I_{\text{mag eff}} = 100\%$	100	100
(1)		110	100
(2)		120	100
(3)		130	100
(4)		140	90
(5)		150	70
(6)		160	55
(7)		170	0

Table 5.20.2 Example of modified characteristic

Parameters

P. no.	Parameter name	Function
P 0340	CON_FM_Imag	Effective value of the rated current for magnetization
P 0341	CON_FM_ImagSLim	Field-weakening activation point (as % of P 0348 MOT_SNom). This effects the switch to the 1/n characteristic (P 0341 $\neq 0$). For P 0341 = 0 the field-weakening works via the modified characteristic $i_{\text{sd}} = f(n)$. For a synchronous machine this value must be set to 0.
P 0342	CON_FM_SpeedTab	Speed values scaled as % of P 0458 n_{rated} to populate the modified table.
P 0343	CON_FM_ImagTab	d-current scaled as % of P 0340 $I_{\text{mag eff}}$ to populate the modified table.

Table 5.20.3 Parameters for field-weakening

5.21 Field-weakening of ASM voltage controller

The voltage controller is overlaid on the selected characteristic. When using the voltage controller, a portion of the available voltage is used as a control reserve.

The more dynamic the running, the more control reserve is required. In this case it may be that the voltage for rated operation is not sufficient, and also that the controller starts to oscillate.

The PI voltage controller can be optimized by adaptation of the P gain **P 0345 CON_FM_VConKp**, integral-action time **P 0346 CON_FM_VConTn** and filter time constant for motor voltage feedback **P 0344 CON_FM_VConTF**. Parameter **P 0347 CON_FM_VRef** sets the voltage reference, though the threshold needs to be reduced in response to rising demands as this maintains a kind of voltage reserve for dynamic control processes. A certain voltage reserve is necessary for stable operation. It is specified by way of parameter **P 0347 CON_FM_VRef** (> 100%). The value should be set high (> 90%) where there are high demands in terms of dynamism. For less dynamic response, the maximum attainable torque can be optimized by higher values (> 90%).

Parameters

P. no.	Parameter name	Function
P 0344	CON_FM_VConTF	Time constant of voltage controller actual value filter
P 0345	CON_FM_VConKp	Voltage controller gain factor Kp
P 0346	CON_FM_VConTn	Voltage controller integral-action time Tn
P 0347	CON_FM_VRef	Voltage controller reference (as % of the current DC link voltage) If the value 0 % is set, the controller is not active.
P 0458	MOT_SNom	Rated speed of the motor

Tabelle 5.21.1 Parameter description, voltage controller



NOTE:

If the control reserve is too small, the inverter typically shuts off with an overcurrent error.

5.22 Synchronous machine field-weakening

Synchronous motors can also be operated above their rated speed at rated voltage, by reducing their voltage consumption based on on injection of a current component.

Features

- The method is relatively robust against parameter fluctuations.
- The voltage controller can only follow rapid speed and torque changes to a limited degree.
- A non-optimized voltage controller may cause oscillation; the controller must be optimized.

Conditions

To effectively reduce the voltage consumption, the ratio of stator inductance **P 0471 MOT_Lsig** multiplied by the rated current P 0457 MOT_CNom to rotor flux **P 0462 MOT_FluxNom** must be sufficiently large. In contrast to field-weakening of asynchronous motors, synchronous motors can also be operated in the "field-weakening range" with full rated torque at the nominal value of the q-current. Power beyond the rated power output can therefore be drawn from the machine in field-weakening mode, even at rated current. This must be taken into consideration when configuring the motor.

P 0435 CON_FM_FWMode.

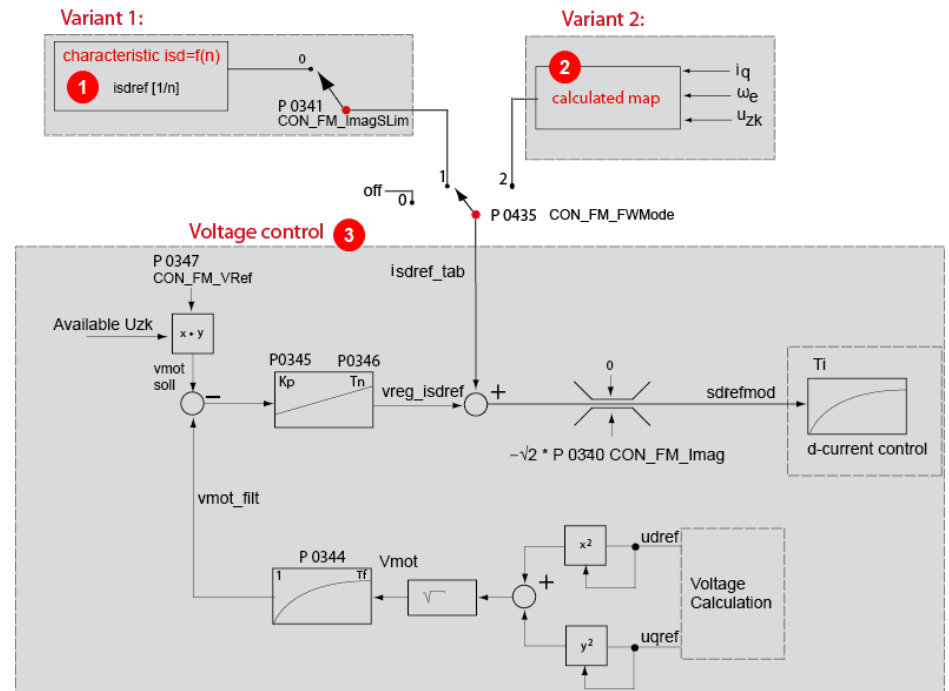

1	Characteristic $i_{sd} = f(n)$
2	Calculated map
3	Voltage controller

Bild 5.22.1 Field-weakening variants 1 and 2

$$C_{Nom} * L_{sig} > 0,2 * \text{Fluß}_{Nom}$$

P 0457 P 0471 P 0482

Empfehlung: Faktor > 0,2

Voltage demand

$$\text{Rotorfluß} * \text{max. Drehzahl}_{(in \text{ rad/s})} * \text{Polpaarzahl} * \sqrt{3} < \begin{matrix} 800 \text{ V (400 V device)} \\ 400 \text{ V (230 V device)} \end{matrix}$$

$$P 0462 * P 458 * P 0328 * \frac{2\pi}{60} * P 0463 * \sqrt{3} < \begin{matrix} 800 \text{ V (400 V device)} \\ 400 \text{ V (230 V device)} \end{matrix}$$

ATTENTION:



If the speed achieved by field-weakening is so high that the induced voltage exceeds the overvoltage threshold of the device (for 400 V devices approximately 800 V, for 230 V devices approximately 400 V), this will result in destruction of the servocontroller if no additional external safety measures are applied.

Field-weakening for the synchronous motor:

There are two variants for field-weakening of a synchronous motor. The choice of variant 1 or 2 is made via parameter

Vorgehensweise: Variant 1: Characteristic $i_{sd} = f(n)$ (Table)

- Deactivate table: **P 0341 CON_FM_ImagSlim = 0**
- **P 0435 CON_FM_FwMode = (1)** Select Table
- Approach desired speeds slowly
- Adjust scope: $i_{sdref}/SQU2 * I_{mag} = \% =$ field-weakening speed. The maximum amount of the "field-weakening" d-current is defined by parameter **P 0340 CON_FM_Imag** (specification of effective value).
- Enter values in table **P 0342 CON_FM_SpeedTab**

Vorgehensweise: Variant 2: "Calculated map" (calc)

In the case of very rapid speed or load changes in the field-weakening range, the setting **P 0435 CON_FM_FwMode = 2** is selected. A characteristic for a higher control dynamism is calculated internally.

Features

- Very fast adaptations, with high dynamism, are possible (open-loop control method).
- Motor parameters must be known quite precisely.

- If continuous oscillation occurs (voltage limit) the preset negative d-current value is then not sufficient. Scaling parameter **P 0436 CON_FW_SpeedScale > 100 %** is used to evaluate the map at higher speeds.

The voltage controller overlaid over the map (setting as described in variant 1).

The set combination of voltage controller and map entails more commissioning commitment, but it enables the best stationary behaviour (highest torque relative to current) and the best dynamic response to be achieved.

Example

The speeds in **P 0342 CON_FM_SpeedTab** must continuously increase from index 0 -7.

Example:

Index	P 0348 rated speed P 0340 $I_{mag\ eff}$	P 0342 (0-7) Field-weakening speed in [%]	P 0343 (0-7) Magnetizing current i_{sdref} in field- weakening mode in [%]
(0)	$n_{rated} = 1800\ rpm$ $I_{mag\ eff} = 100\ \%$	100	0
(1)		110	55
(2)		120	70
(3)		130	90
(4)		140	100
(5)		150	100
(6)		160	100
(7)		170	100

Tabelle 5.22.2 Speeds in **P 0342 CON_FM_SpeedTab**

Parameters

P. no.	Parameter name	Function
P 0435	CON_FM_FWMode	Selection mode for field-weakening of synchronous motors
(0)	None	Field-weakening is off, regardless of other settings.
(1)	Table	Field-weakening is effected by a characteristic which specifies the d-current dependent on the speed $i_{sd} = f(n)$ P 0342 CON_FM_SpeedTab parameter and P 0343 Con_TAB_POSDelta .
(2)	Calc	Field-weakening is effected by way of a characteristic which is set internally via the motor parameters. The d-current reference is then calculated dependent on the speed AND the required q-current: $i_{sd} = f(n, i_{sq_ref})$. The inaccuracies with regard to the motor parameters, the available voltage etc. can be compensated by way of the Scale parameter P 0436 CON_FW_SpeedScale .

Tabelle 5.22.3 Selection mode for field-weakening



ATTENTION:

When configuring projects, it must be ensured that the speed **NEVER** exceeds the value of the product of **P 0458 MOT_SNom** x **P 0328_CON_SCON_SMax**. It should be ensured as a matter of principle that the induced voltage does not exceed the voltage limits. The maximum system speed must not be exceeded.

5.23 SM voltage controller field-weakening

The voltage controller is overlaid on the selected characteristic. When using the voltage controller, a portion of the available voltage is used as a control reserve. The more dynamic the running, the more control reserve is required. In this case it may be that the voltage for rated operation is not sufficient, and also that the controller starts to oscillate.

If the voltage controller oscillates the gain must be reduced. If substantial variations between the q-current reference and actual values occur during run-up to reference speed in the field-weakening range, the drive may be at the voltage limit. In this case, a check should first be made as to whether the preset maximum value **P 0340 CON_FM_Imag** has already been reached and can be increased. If the maximum value has not yet been reached, the voltage controller is not dynamic enough and the gain

P 0345 CON_FM_VConKp must be increased.

If no suitable compromise can be found, the voltage threshold as from which the voltage control intervenes must be reduced by the scaling parameter **P 0347 CON_FM_VRef**. If the response with voltage controller is unproblematic and no particular demands are made in terms of dynamism, the available torque can be optimized by setting **P 0347 CON_FM_VRef** to values up to 98%.

5.24 Autocommutation for synchronous machines

For field-oriented regulation of permanently excited synchronous machines with a purely incremental measuring system, the commutation position must be determined once when the control is started (adjustment of current rotor position to encoder zero [encoder offset]).

This procedure is executed by the "Autocommutation" function after initial enabling of the control when the mains voltage has been switched on for the first time. It can also be forced during commissioning by changing a parameter, which causes a complete controller initialization (e.g. change of autocommutation parameters, change of control mode, etc.).

Owing to the differing requirements arising from the applications, various commutation methods are provided (**P 0390 CON_ICOM**).

To check in commissioning whether the autocommutation has been successful, parameter **P 0394 CON_ICOM_Check** is provided. It comprises the current commutation angle error ActVal (1) and a parameterizable limit value Limit(0). If the commutation angle error exceeds the specified limit value, an error is generated.

5.24.1 IENCC(1) method

In this method the rotor aligns in the direction of the injected current and thus in a defined position. The relatively large movement (up to half a rotor revolution) must be taken into consideration. This method cannot be used near end stops or limit switches! For the injected current it is advisable to use the rated current I_{rated} . The time should be set so that the rotor is at rest during the measurement. For control purposes, the commutation process can be recorded with the Scope function.

NOTE:



- Inexperienced users should always choose the rated motor current (amplitude) as the current and a time of at least 2000 ms.
- The motor may move jerkily during autocommutation. The coupled mechanical system must be rated accordingly. If the axis is blocked, meaning the rotor is unable to align itself, the method will not work correctly. As a result, the commutation angle will be incorrectly defined and the motor may perform uncontrolled movements.
- When calculating the data sets of linear motors the values for time and current adjust automatically.

5.24.2 IECON(4) method

The motor shaft motion can be minimized by a shaft angle controller. The structure and parameters of the speed controller are used for the purpose. The gain can be scaled via parameter **P 0391 CON_ICOM_KpScale**. The precondition is a preset speed control loop. Increasing the gain results in a reduction of the motion.

An excessively high gain will result in oscillation and noise. In both methods (1) and (4), the flux forming current "Isdref" is injected as a test signal. The diagram illustrates the IECON(4) method.

IECON(4) Verfahren



Bild 5.24.1 IECON(4): Minimal movement of the motor shaft

5.24.3 LHMES(2) method

With this method, saturation effects in stator inductance are evaluated. Two test signal sequences are used for this purpose, whereby the position of the rotor axis is known after the first sequence and the direction of movement after the second. This method is suitable for determining the rotor position with braked rotors or motors with a high mass inertia.

Vorgehensweise: LHMES commutation

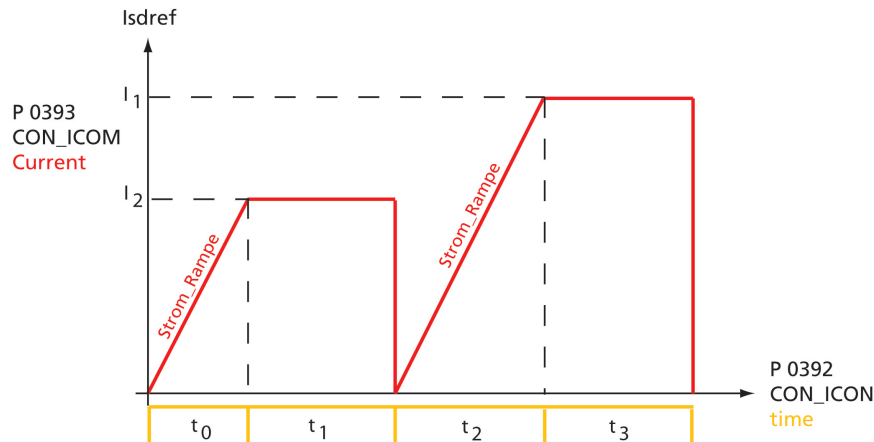
Test signal frequency setting:

In parameter **P 0392 CON_ICOM_Time[2]** the period of the test signal frequency is entered. If this value is 0, the controller uses a default test signal frequency of 100 Hz (period 10 ms). The amplitude of the test signal can be varied via parameter **P 0393 CON_ICOM_Current[0]**. If the value 0 is specified, the amplitude is derived from the motor rated current. If an amplitude greater than the switching frequency-dependent power stage current is specified, the amplitude is limited to half the power stage current.

The equal portion of the test signals is set via parameter **P 0393 CON_ICOM_Current[1]**. If this value is 0, the equal portion is determined from the motor rated current.

A simple parameter setting is obtained by specifying the value 0 for parameters **P 0392 CON_ICOM_Time[2]**, **P 0393 CON_ICOM_Current[0]** and **P 0393 CON_ICOM_Current[1]**. The parameters are then assigned default values which are derived from the motor/power stage current. Then the measurement is performed.



NOTE:

In order to utilize the very complex LHMES autocommutation method, consultation with LTI DRIVES GmbH is required.

Precondition:

The rotor must be firmly braked. It must not move when the rated current is applied. The stator of the machine must be iron-core. Example:

P1503	Direct component	3.1 A
P1505	Amplitude	1 A
P1506	Frequency of test signal	f = 333 Hz
P1508	Number of periods	50

Tabelle 5.24.1 Setting example



NOTE:

It is advisable to check speed tracking error monitoring with the "Power stage off" error reaction. This monitoring feature prevents the motor from racing.



ATTENTION:

Parameters of the "Autocommutation" subject area may only be changed by qualified personnel. If they are set incorrectly the motor may start up in an uncontrolled manner.

Parameters

P. no.	Parameter name	Function
P 0390	CON_ICOM	Selection of commutation variant
(0)	OFF (0)	No autocommutation
(1)	IENCC(1)	Autocommutation IENCC (1) with movement: Motor moves as far as half a rotor revolution, or half a pole pitch period (with p = 1).
(2)	LHMESS(2)	Autocommutation LHMES (2) with braked machine: The machine must be blocked by a suitable brake during autocommutation. The occurring torques and forces may attain the rated torque and force of the machine. Apply the method only in consultation with LTi DRIVES GmbH.
(3)	IECSC(3)	-
(4)	IECON(4)	Autocommutation IECON (4) with minimized movement: Here, too, the rotor must be able to move. However, an appropriate parameter setting can reduce the rotor motion to a few degrees/mm.
(5)	HALLS(5)	-
(6)	HALLSdigital (6)	Digital Hall sensor
P 0394	CON_ICOM_ Check	Check whether commutation was successful.
(0)	Limit(0)	Limit value for maximum commutation angle error
(1)	ActVal(1)	Current commutation angle error

Tabelle 5.24.2 Autocommutation parameters

Boost voltage at zero frequency:	<input type="text" value="16.7264"/>	V
Voltage at nominal frequency:	<input type="text" value="200"/>	V
Nominal frequency:	<input type="text" value="225"/>	Hz

Bild 5.25.1 V/f mode dialog box

5.25 V/f mode

In V/f mode in the Closed-loop control subject area it is possible to run a simple test indicating to the user whether a motor is connected correctly and moving in the right direction (linear drive: right/left running). If the direction has been reversed, the motor is stopped or executing uncontrollable movements, the termination and the motor data must be checked.

As a test mode, a voltage/frequency control system is implemented in such a way that the closed-loop speed control circuit is replaced by open-loop control. So the reference in this case is also the speed reference; the actual speed is set equal to the reference. A linear characteristic with two interpolation points is implemented, with a fixed boost voltage setting **P 0313 CON_VFC_VBoost** at 0 Hertz. As from the rated frequency **P 0314 CON_VFC_FNom** the output voltage remains constant. An asynchronous machine is thus automatically driven into field-weakening as the frequency rises.

5.26 Function of process controller

The process controller function enables a measured process variable to be controlled to a reference (setpoint) value.

5.26.1 Features

- Process controller calculation in speed controller cycle
- Process controller as PI controller with Kp adaptation
- Process controller actual value selectable via selector
- Filtering and offset correct of reference and actual values
- Process controller output can be connected to different points in the general control structure
- Process controller is usable in all control modes

Controller structure



Bild 5.26.1 Schematic of process controller

Vorgehensweise: Process controller setup

- Set process controller reference value:
P 2666 CON_PRC_REFVAL: Reference input in user units (this parameter can be written cyclically over a field bus)
- Scaling of process controller reference value:
P 2667 CON_PRC_REFSCALE; The reference **P 2666 CON_PRC_REFVAL** can be scaled (taking into account the user units), see Application Manual, "Scaling".
- Select actual value sources:
P 2668 CON_PRC_ACTSEL: The actual value source must be set to the desired reference source (e.g. field bus). The field bus writes the actual value to parameter
P 2677 CON_PRC_ACTVAL_FIELDBUS
- Select offset
Optional, **P 2669 CON_PRC_ACTOFFSET**: Setting of an offset for actual value calibration
- Scaling of process controller actual value:
P 2670 CON_PRC_ACTTF; filter time for actual value filter [ms]. The actual value is smoothed via the integral-action time of the PT-1 filter. (taking into account the user units)
- Inversion of the control difference
P 2665 CON_PRC_CDIF_SIGN: Adaptation of control difference sign
- Activate process controller:
P 2681 CON_PRC_CtrlWord: Control word bit 0 = 1 (process controller active). This bit must be reset after every restart. The bit is not stored in the data set.
- Optimization of controller setup:
P 2659 CON_PRC_Kp: Controller gain
P 2660 CON_PRC_KP_SCALE: Scaling of gain
P 2661 CON_PRC_Tn: **TN** integral-action time: If the integral-action time is set to the permissible maximum value, the I-component of the controller is inactive (10000 ms = off).
- Offset for the process controller output
P 2662 CON_PRC_REFOFFSET: Then the totalled variable is connected via a limitation to the output of the process control loop. The user can parameterize the limitation via parameter
P 2663 CON_PRC_LIMPOS for the positive limit and
P 2664 CON_PRC_LIMNEG for the negative limit.

5.26.2 Rate limiter

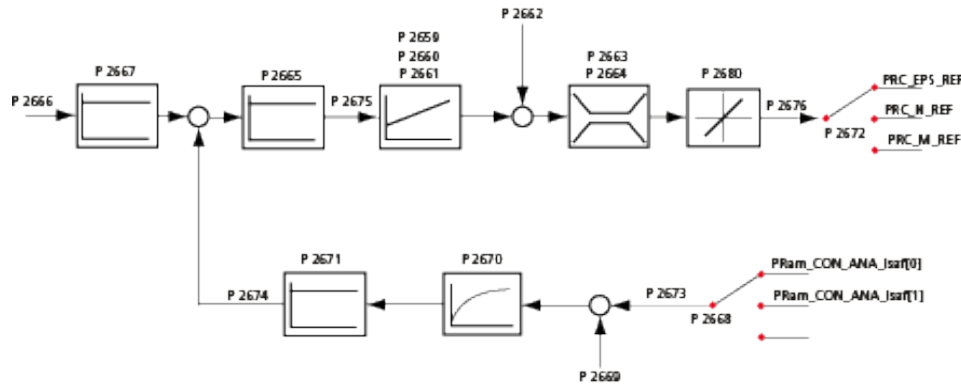
Downstream of the control variable limiter there is another limitation which limits the changes to the control variable per sampling segment. By way of field parameter

P 2680 CON_PRC_Rate Limiter the limitation of the control variable steepness per millisecond can be parameterized. By way of index (0) the limitation is active in standard process controller operation. By way of index (1) reduction of the I-component is activated (see table).

With **P 2672 CON_PRC_OUTSEL = 3** the process controller delivers an additive position reference value. The rate limiter limits the possible control variable change. The control variable change each time interval by the process controller results in a speed change on the motor shaft.

Example

The amount of the process controller to change the speed on the motor shaft should not be higher than 100 revolutions per minute. To achieve this, the value of parameter **P 2680 (0) CON_PRC_Rate Limiter** must be parameterized with a value corresponding to the user unit. The unit of this parameter is [x/ms]. The x stands for the respective unit of the process controller output variable. In this example the control variable (additive position reference) has the unit "Increments"

(see also parameter **P 270 MPRO_FG_PosNorm**). This parameter indicates how many increments correspond to one motor revolution.

Conversion from [rpm] to [Inc/ms]

$$n_{\text{change}} = 100 \text{ rpm}$$

P 0270 MPRO_FG_PosNorm in inc/rev

Internal position resolution = 1048576 inc/rev (default)

To reduce the I-component, the same method is applicable

P 2680(1) CON_PRC_Rate Limiter(1) [Inc/ms]).

$$\mathbf{P\ 2680\ CON_PRC_Rate\ Limiter} = n_{\text{change}} * 1048576 * 1/60000$$

$$\mathbf{P\ 2680\ [Inc/ms]} = 100 \text{ [rpm]} * \mathbf{P\ 0270\ [Inc/rev]} * 1/60 \text{ [min/s*]} * 1/1000 \text{ [s/ms]}$$

Scope signals for visualization of the process control loop

No.	Parameter name	Function
P2675	CON_PRC_Cdiff_	Control difference of the process controller
P2666	CON_PRC_RefVal	Process controller reference
P2673	CON_PRC_Raw_ActVal	Actual value of the selected actual value source)
P2674	CON_RPC_Actval	Momentary actual value of the process controller; after filtering and scaling
P2676	CCON_PRC_Outval	Process controller control variable

Tabelle 5.26.1 Scope signals

Process controller parameters

P. no.	Parameter name	Function
P2659	CON_PRC_Kp	P-gain of the process controller

P. no.	Parameter name	Function
P2660	CON_PRC_KP_SCALE	Adaptation of the P-gain
P2661	CON_PRC_Tn	Process controller integral-action time
P2662	CON_PRC_REFOFFSET	Offset for the process controller output
P2663	CON_PRC_LIMPOS	Positive process controller limitation
P2664	CON_PRC_LIMNEG	Negative process controller limitation
P2665	CON_PRC_CDIFF_SIGN	Adaptation of control difference sign
P2666	CON_PRC_REFVAL	Process control reference value
P2667	CON_PRC_REFSCALE	Scaling factor for the process controller reference
P2668	CON_PRC_ACTSEL	Selection of the actual value source
(0)	ISA00	Analog input 0
(1)	ISA01	Analog input 1
(2)	Fieldbus	Field bus parameter CON_PRC_ACTVAL_Fieldbus-ID 2677
(3)	REFSPEED	Actual speed [rpm]
(4)	REFPOS	Actual position [increments]
(5)	ISQREF	This function requires further parameter settings

P. no.	Parameter name	Function
		- see "Rack and Pinion Control (RPDC)". (Only on request)
P2669	CON_PRC_ACTOFFSET	Offset for actual value calibration
P2670	CON_PRC_ACTTF	Filter time for actual value filter
P2671	CON_PRC_ACTSCALE	Scaling for the filtered process actual value
P2672	CON_PRC_OUTSEL	Selection parameter for the process controller output
(0)	OFF	OFF
(1)	REFTORQUE	Additive torque reference
(2)	REFSPEED	Additive speed reference
(3)	REFPOS	Additive position reference
(4)	MOPRO_ Output to P 2678	Value for MotionProfile (CON_PRC_OUTSEL_ MOPRO - ID 2678)
P2673	CON_PRC_RAW_ACTVAL	Actual value of the selected actual value source
P2674	CON_PRC_ACTVAL	Momentary actual value of the process controller after filtering and scaling
P2675	CON_PRC_CDIFF	Control difference of the process control loop
P2676	CON_PRC_	Process controller control variable

P. no.	Parameter name	Function
	OUTVAL	
P2677	CON_PRC_ACTVAL_FIELD BUS	Parameter to which an actual value can be written from the field bus
P2678	CON_PRC_OUTSEL_MOPRO	Parameter to which the control variable can be written in order to be subsequently used in the motion profile.
P2679	CON_PRC_RefReached	"Reference reached" window
P2680	CON_PRC_RateLimiter	Steepness limitation of the control variable
(0)	RateLimiter	Steepness limitation in standard process controller operation; unit: [Userunits/ms]
(1)	RateLimiter	Steepness limitation to reduce the process controller I-component; unit: [Userunits/ms]
P2681	CON_PRC_CtrlWord	Control word of the process controller
(0)	PRC_CTRL_ON	Bit 0 = 1: START; switch on process controller
(1)	PRC_CTRL_ResetIReady	Bit 1 = 1: Reset I-component via ramp after P 2680 /subindex 1
(2)	PRC_CTRL_FREE	Bit 2-7 Reserve
P2882	CON_PRC_StatWord	Status word of the process controller
(0)	PRC_STAT_On	The value of bit 0 indicates whether the process

P. no.	Parameter name	Function
		controller is switched on
(1)	PRC_STAT_ResetIReady	Bit 1 signifies that the I-component of the process controller is reduced
(2)	PRC_STAT_FREE	Reserve
P2683	CON_PRC_REFSEL	Selection of reference source
(0)	USER	User reference of P 2684
(1)	RPDC	Reference of planetary gear
(2)	ISA00	Reference of analog input ISA00
(3)	ISA01	Reference value of analog input ISA01
P2684	CON_PRC_REFVAL_User	User input of process control reference

Table 5.26.2 Process controller parameters

6 Motion profile

Information	
Navigation	Project tree < Device setup < Motion profile
Pictograms	 Bewegungsprofil
Subject	<ul style="list-style-type: none"> • Setting the motion profile.htm • Basic settings.htm • Synchronized movement: Setting electronic gearing.htm • Scaling / Units: Scaling.htm • Homing methods Homing.htm • Jog mode.htm • Reference table.htm • Analog channel.htm • Stop ramps.htm • State machine.htm • Touchprobe.htm • Virtual master.htm • Profile generator Speed control in PG mode.htm • Interpolation types.htm

Tabelle 6.0.1 Motion profile subject area

6.1 Motion profile setting

In the Motion Profile subject area the drive settings are made in relation to open-loop control, units and commands.



Bild 6.1.1 "Motion profile" dialog box

Description of dialog box

Number	Information
1	Scaling profile: <ul style="list-style-type: none"> Standard/CiA 402 SERCOS User-defined
2	Setting of control and reference value channel: <ul style="list-style-type: none"> Control/Reference Profile Interpolation Limitation Reference filter Smoothing
3	Stop ramps / Reaction: <ul style="list-style-type: none"> to Shutdown to Disable to Halt to Quickstop to Fault Setting of quick-stop ramp
4	Selection of homing method: <ul style="list-style-type: none"> Homing method Speeds (cam/zero point search) Acceleration Offset Homing maximum distance
5	Jog speeds <ul style="list-style-type: none"> Fast jog Slow jog

Number	Information
6	Synchronized movement: <ul style="list-style-type: none"> • Master configuration • Electronic gearing • Electronic cam plate
7	Details: Additional settings for closed-loop control and reference

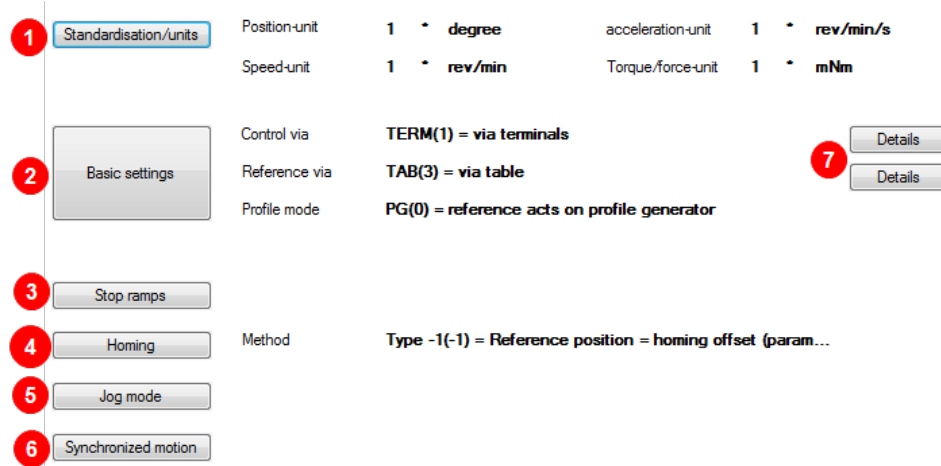
Tabelle 6.1.2 Motion profile parameters

6.2 Scaling / Units

6.2.1 Scaling wizard

In the "Motion Profile, Units/Scaling" subject area the physical data of the application are matched to the drive controller. Three scaling profiles are available. For the CiA 402 profile and SERCOS scaling is supported by a wizard. "User-defined" scaling can only be set directly in the parameter editor.

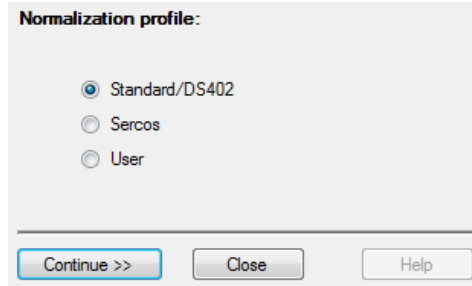
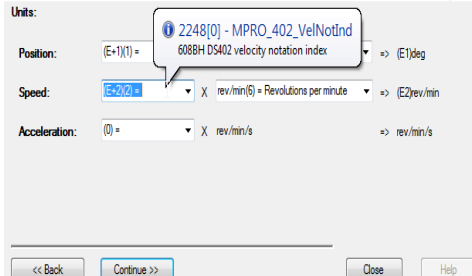
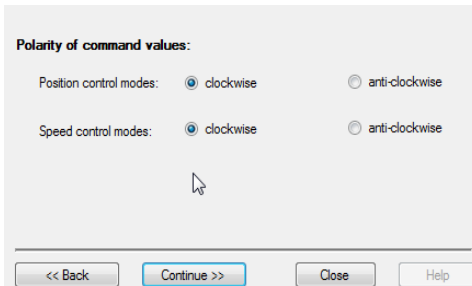
	<p>Selecting the scaling wizard: There is no wizard to assist with "User-defined selection". The parameters must be set using the editor.</p>
	<p>Selecting the units: Definition of the units for position, speed and acceleration. The scaling is entered using the Exponent syntax.</p>
	<p>Definition of directions: Referred to the motor, the positive direction is clockwise as seen when looking at the motor shaft (A-side bearing plate).</p>

Feed constant:
The path travelled is proportionate to one motor revolution or, when using a gear unit, to the output-side revolution.

Gear ratio:
Ratio of one motor revolution before the gearing to the number of revolutions on the gear output side. The values for the gear ratio are entered in the dialog box as integer fractions.

Position controller resolution:
The single-turn resolution of the position controller can be adapted variably to the application. A total of 32 bits are available. In the default setting, 20 of the bits are used for the single-turn position.

Tabelle 6.2.1 CiA402 scaling wizard

6.3 Weighting via the SERCOS profile

When using the SERCOS profile, scaling of the units is termed weighting. The weighting describes the physical unit and the exponent with which the numerical values of the parameters exchanged between the master control system and the drives are to be interpreted. The method of weighting is defined by the parameters for position, speed, force/torque and acceleration weighting.

Bild 6.3.1 Dialog box for scaling via SERCOS

Siehe "Force/torque weighting" auf Seite 134

6.4 Force/torque weighting

6.4.1 Schematic of force/torque weighting

The "Force/torque weighting method" schematic shows the structure with which the acceleration is scaled using the SERCOS wizard. A distinction must be made between linear and rotary weighting in this. In percentage weighting the permanently permissible standstill torque of the motor is used as the reference value. All torque/force data is given in [%] with one decimal place.

Torque polarity:

The polarity of the torque can be inverted according to the application. A positive torque reference indicates clockwise rotation (looking at the motor shaft).



Bild 6.4.1 Force/torque weighting method

Linear weighting

Unit	Weighting factor	Parameter weighting (LSB)
Nm	1	LSB = Unit * Exponent

Tabelle 6.4.2 Weighting for linear motion (default setting)

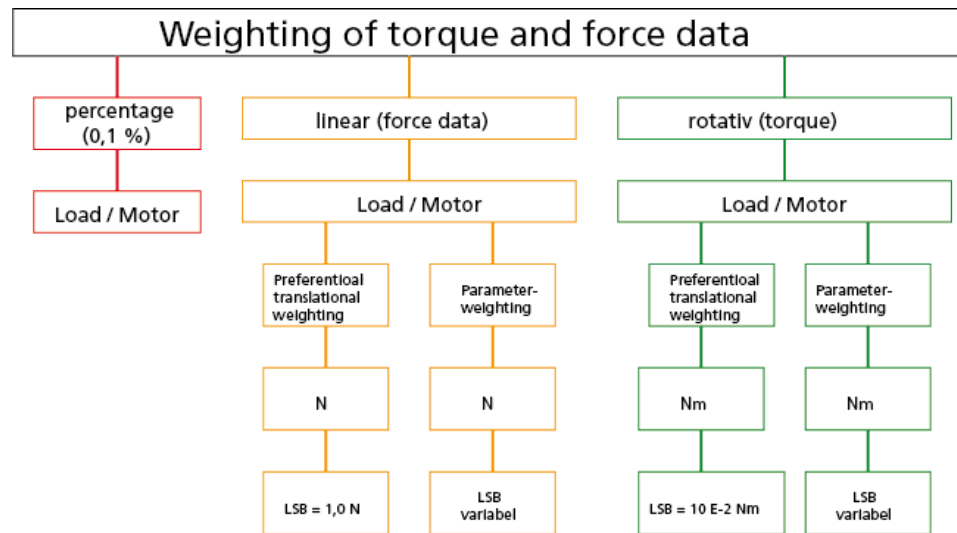
Rotary weighting

Unit	Weighting factor	Preferential weighting (LSB)	Parameter weighting (LSB)
Nm	1	0.01 Nm	LSB = Unit * Exponent

Tabelle 6.4.3 Weighting for rotary motion (default setting)

6.5 Acceleration weighting

6.5.1 Schematic of weighting method

The "Acceleration data weighting method" schematic shows the structure with which the acceleration is scaled using the SERCOS wizard. A distinction must be made between linear and rotary weighting in this.



Bild 6.5.1 Acceleration weighting

Linear weighting

Unit	Weighting factor	Factory setting (LSB)
m/s ²	1	E ⁻⁶

Tabelle 6.5.2 Weighting for linear motion (default setting)

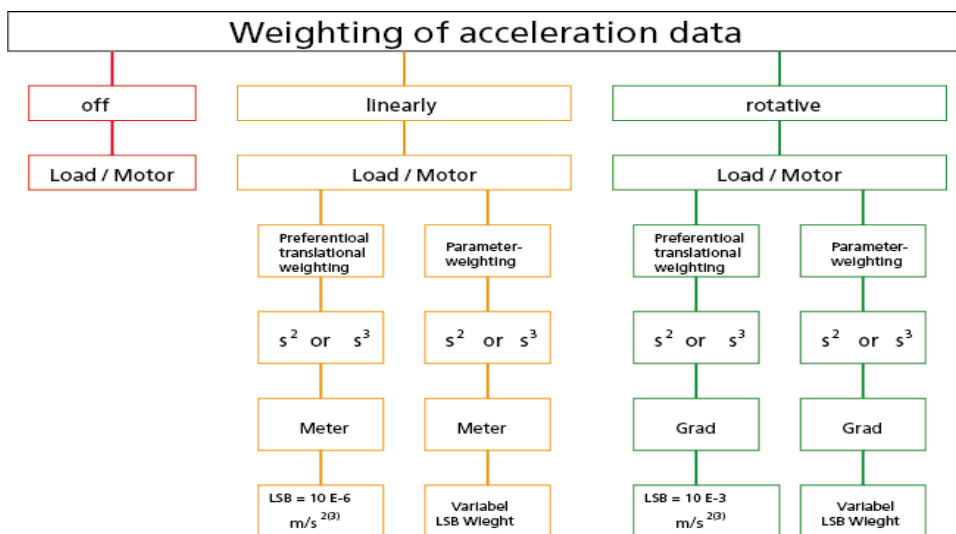
$$\text{LSB} = \text{Einheit} * \text{Exponent} * \frac{\text{Wegeinheit}}{\text{Zeiteinheit}}$$

Rotary weighting

Unit	Weighting factor	Factory setting (LSB)
rad/s ²	3.600.000	E ⁻³

Tabelle 6.5.3 Weighting for rotary motion (default setting)

$$\text{LSB} = \text{Einheit} * \text{Exponent} * \frac{\text{Umdrehungen}}{\text{min}}$$

6.6 Speed weighting

6.6.1 Schematic of weighting method

The "Speed weighting method" schematic shows the structure with which the acceleration is scaled using the SERCOS wizard. A distinction must be made between linear and rotary weighting in this.

Speed polarity:

The polarity of the speed data can be inverted according to the application. A positive speed reference indicates clockwise rotation (looking at the motor shaft).



Bild 6.6.1 Speed data weighting method

Linear weighting

Unit	Weighting factor	Preferential weighting (LSB)
m/min	1	0.001 m/min

Tabelle 6.6.2 Weighting for linear motion (default setting)

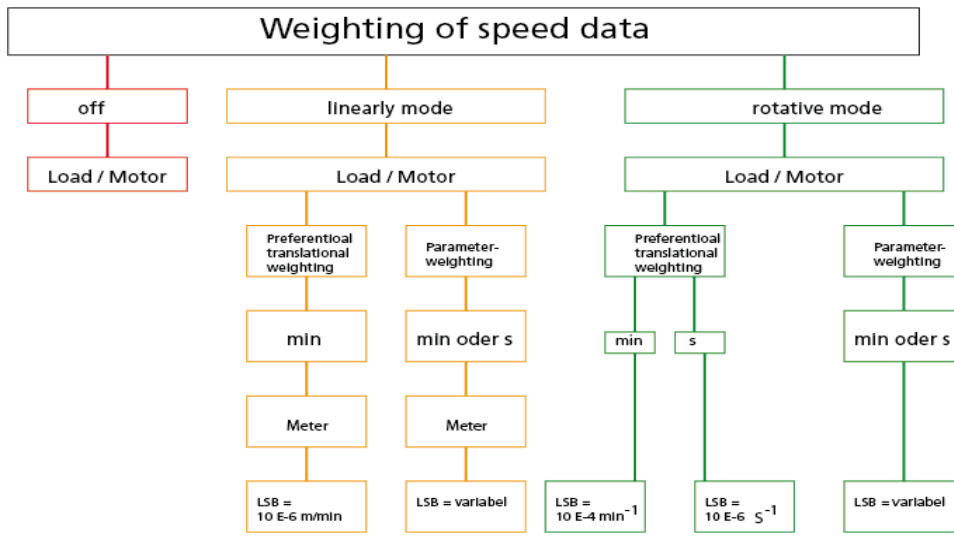
$$LSB = \text{Einheit} * \text{Exponent} * \frac{\text{Wegeinheit}}{\text{Zeiteinheit}}$$

Rotary weighting

Weighting method	Unit	Weighting factor	Preferential weighting (LSB)
rotary	Degrees	3.600.000	0.001 m/min

Tabelle 6.6.3 Weighting for rotary motion (default setting)

$$LSB = \text{Einheit} * \text{Exponent} * \frac{\text{Umdrehungen}}{\text{min}}$$

6.7 Weighting of position data

6.7.1 Schematic of position data weighting

The "Position weighting method" schematic shows the structure with which the acceleration is scaled using the SERCOS wizard. A distinction must be made between linear and rotary weighting in this.

Position polarity:

The polarity of the position data can be inverted according to the application. An increasing actual position value indicates clockwise rotation (looking at the motor shaft).



Bild 6.7.1 Position data weighting method

Linear weighting

Unit	Weighting factor	Preferential weighting (LSB)
m	1	E ⁻⁷

Tabelle 6.7.2 Weighting for linear motion (default setting)

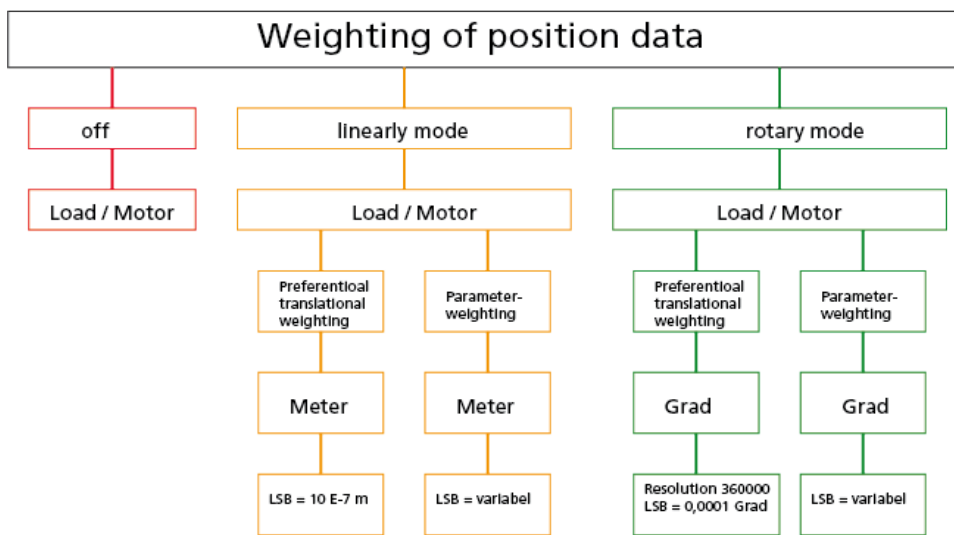
Rotary weighting

Weighting method	Unit	Weighting factor	Preferential weighting (LSB)
rotary	Degrees	3.600.000	0.0001 µm

Tabelle 6.7.3 Weighting for rotary motion (default setting)

$$\text{LSB} = \text{Einheit} * \frac{1 \text{ U/min}}{\text{rotative Lageauflösung}}$$

$$\text{LSB} = \frac{360^\circ}{3\,600\,000}$$

6.8 Modulo weighting

If Modulo (indexing table application) is to be selected, the number range of the position data (modulo value) must be entered. When the modulo value is exceeded the actual position is reset to 0.

6.9 User-defined scaling

No wizard is available for user-defined scaling. The following schematic is provided as an aid to parameter setting. Calculation of the factors for position, speed and acceleration is dependent on the selected user unit and the feed constant or gear ratio.

User-defined scaling



Bild 6.9.1 Schematic of user-defined scaling

Parameters

P. no.	Parameter name	Function	Default Rotary system
P 0270	MPRO_FG_PosNom	Increments per revolution	1048576 [incr/rev]
P 0271	MPRO_FG_Nom	Numerator	1[rev]
P 0272	MPRO_FG_Den	Denominator	360° [POS]
P 0273	MPRO_FG_Reverse	Reverse direction	False = clockwise

P. no.	Parameter name	Function	Default Rotary system
P 0274	MPRO_FG_SpeedFac	Speed factor	1[rpm]
P 0275	MPRO_FG_AccFac	Acceleration factor	1/60 = 0.01667 [rpm/s]
P 0284	MPRO_FG_PosUnit	Unit for position value	mdegree
P 0287	MPRO_FG_SpeetUnit	Unit for speed value	rev/min
P 0290	MPRO_FG_AccUnit	Unit for acceleration value	rev/min/s

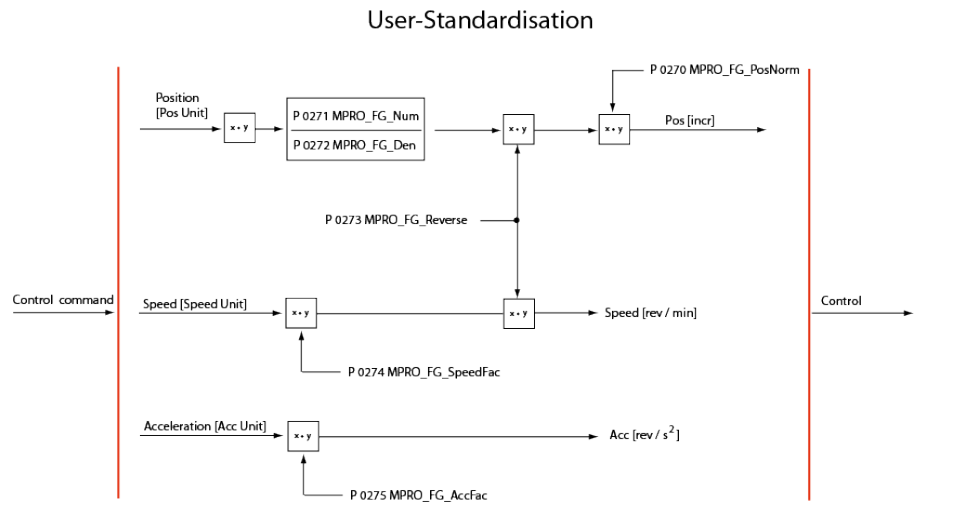
Tabelle 6.9.2 Parameters for user-defined scaling (rotary system)

Example of scaling of a rotary motor:

Presetting: 1 motor revolution corresponds to 360° or 1048576 increments

- Speed in [rpm]
- Acceleration in [rpm/s]
- Positioning in [°degrees]

Given:

Position unit P 0284 MPRO_FG_PosUnit = [µm]
 Speed unit P 0287 MPRO_FG_SpeedUnit = [m/s]
 Acceleration unit P 0290 MPRO_FG_AccUnit = [m/s²]
 Feed constant: 0.1 mm = 1 rev

Gearing: 1 drive revolution = 3 motor revs

Parameter setting

P 0284 MPRO_FG_PosUnit = 1 μm = 1/1000 mm = 10/1000 rev (output) = 30/1000 rev (motor)
 P 0271 MPRO_FG_Nom = 3
 P 0272 MPRO_FG_Den = 100
 P 0287 MPRO_FG_SpeedUnit = 1 m/s = 1000 mm/s = 10 000 rev/s (output) = 30 000 rev/s (motor)*60 (min) = 1 800 000 rev/min
 P 0275 MPRO_FG_SpeedFac = 1 800 000
 P 0290 MPRO_FG_AccUnit = 1 m/s² = 1000 mm/s² = 10 000 rev/s (output) = 30 000 rev/s² (motor)*60 (min) = 1 800 000 rev/min

Example of scaling of a linear motor

Presetting: One revolution corresponds to 32 mm pitch

- Travel in [μm]
- Speed in [mm/sec]
- Acceleration in [mm/s²]

Parameter setting:

P. no.	Parameter name	Function	Default Rotary system
P 0270	MPRO_FG_PosNom	Increments per revolution	1048576 [incr/rev]
P 0271	MPRO_FG_Nom	Numerator	1[rev]
P 0272	MPRO_FG_Den	Denominator	32000 μm

P. no.	Parameter name	Function	Default Rotary system
P 0273	MPRO_FG_Reverse	Reverse direction	False = clockwise
P 0274	MPRO_FG_SpeedFac	Speed factor	1.875 rps corresponds to 1 mm/s, 1/32 mm = 0.03125 rps ² 0.03125 rps ² *60 s = 1.875 rps
P 0275	MPRO_FG_AccFac	Acceleration factor	1/32 mm = 0.03125 rps ² corresponding to 1mm/s ²

Tabelle 6.9.3 Parameters for user-defined scaling (linear system)

Siehe "Scaling / Units" auf Seite 132

6.10 Indexing table function setting "as linear"

The indexing table function is set up in the "Motion profile scaling" subject area. For the circumferential length (upper position) a limit value must be entered specifying the point at which a revolution is complete.

Example of a revolution with a circumferential length of 360°, setting "as linear":

The circumferential length is set to 360°. On reaching 360° the actual position is set to 0°. It is not necessary to preset a negative reference for the reversal of direction.



Bild 6.10.1 Dialog box: Indexing table function "as linear"

6.11 Indexing table function direction of rotation setting

6.11.1 "Direction of rotation" setting

The indexing table function is set up in the "Motion profile scaling" subject area. For the upper position a limit value must be entered specifying the point at which a revolution is complete.

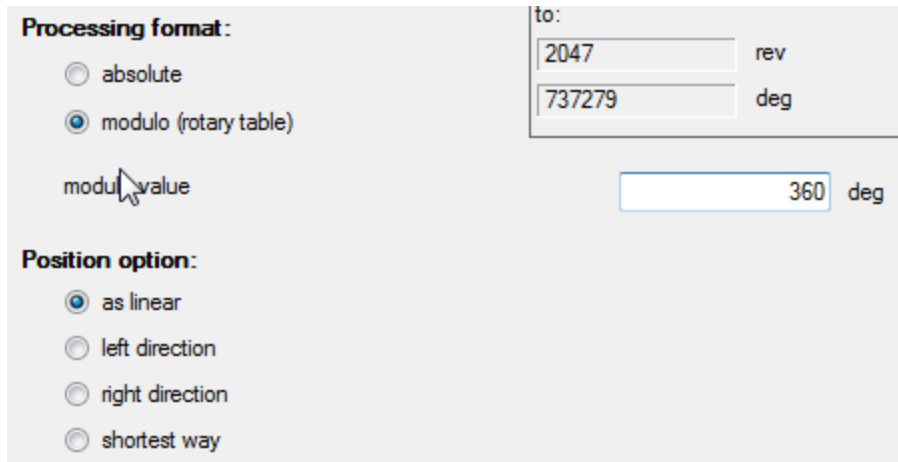
Example of a revolution with a circumferential length of 360°, setting "Direction of rotation left/right"

The circumferential length is set to 360°. In positive direction, after reaching 360° the actual position is set to 0°. The same applies to the negative direction. On reaching 0° the actual position is set to 360°.

Direction left/right



Tabelle 6.11.1 Dialog box: "Indexing table functions" Direction of rotation right/left

6.12 Indexing table function path-optimized

6.12.1 Path-optimized movement

An absolute target position is always approached by the shortest path. Relative movements are not executed "path-optimized".

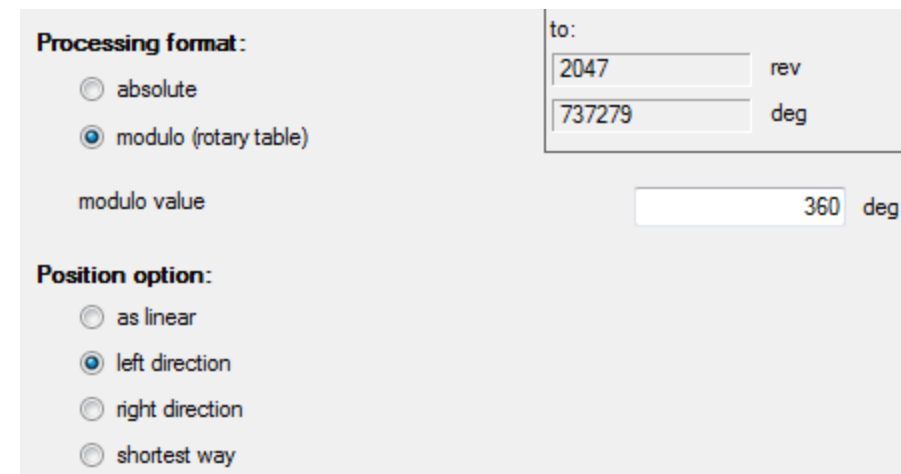
Position range	Effect
Target position < circumference (Example $120^\circ < 360^\circ$)	The drive moves to the target position within 360° .
Target position = circumference (Example $120^\circ = 120^\circ$)	The drive remains in position.
Target position > circumference (Example $600^\circ - 360^\circ = 240^\circ$)	The drive moves to the position within the circumference (target position - (n x circumferential length))

Tabelle 6.12.1 Path-optimized movement

Graphic for indexing table with/without path optimization



Bild 6.12.2 Path optimization

6.13 Indexing table function "Infinite driving job"

In the case of infinite driving jobs the drive moves at constant speed, regardless of a transmitted target position, until the mode is deactivated or is overwritten by a new driving job. On switching to the next driving set (absolute or relative), the new target position is approached in the current direction of movement. A preset path optimization is ignored when the indexing table is active.

6.14 Indexing table function "Relative driving job"

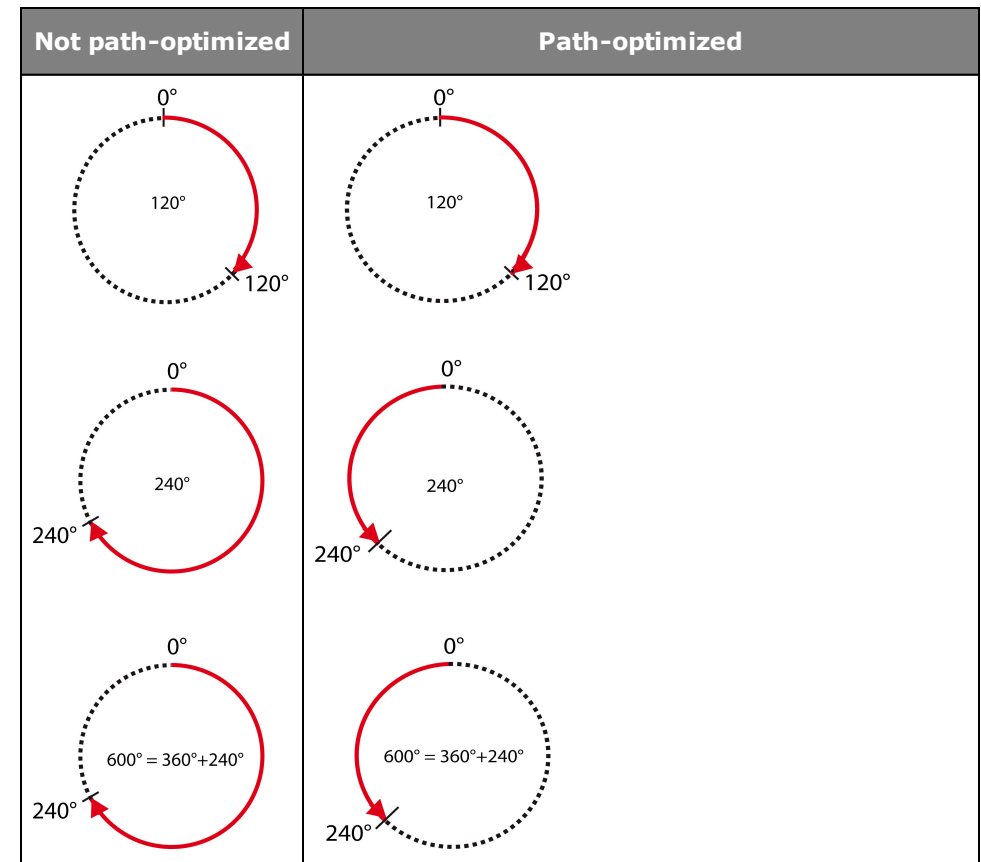
Relative driving jobs may relate to the current target position or to the actual position. For more information see "Field Buses" user manuals. In the case of relative driving jobs greater travel distances than the circumferential length are possible.

Example without gear ratio:

- Circumferential length = 360°
- Relative target position = 800°
- Start position = 0°
- Movement:
The drive performs two motor revolutions (720°) and stops on the third at 80° (800° - 720°).

6.15 Motion profile basic settings

6.15.1 Motion profile basic setting selection dialog box

In the motion profile settings are made relating to closed-loop control, reference input, profile, interpolation, limitation and reference filtering. The reference filters are initialized only after the control has been re-enabled or by a device restart.

Set control and reference

Control via: TERM(1) = via terminals

Reference via: TAB(3) = via table

Motor control start condition: OFF(0) = Switch off drive first in case of power or fault reset

Profile

Profile mode: PG(0) = reference acts on profile generator

Profile type: LinRamp(0) = Linear ramp (trapezoidal profile)

Interpolation

Interpolation type: SplineII(3) = Cubic spline interpolation

Cycle time: 1 ms

Limit

Speed override: 100 %

Reversing lock: OFF(0) = No locking

Reference filter

Filter type: OFF(0) = Function disabled

Bild 6.15.1 Basic setting dialog box

Parameters

P. no.	Parameter name/ Settings	Function
P 0144	MPRO_ DRVCOM_ Auto_start	Autostart function
(0)	Off	Normal operation: The drive is stopped by cancelling the start condition.
(1)	ON	The drive starts immediately when the initialization is complete.
P 0159	MPRO_CTRL_ SEL	
(0)	OFF	No control location selected
(1)	TERM	Control via terminal
(2)	PARA	Control via parameter
(3)	Off	Not defined
(4)	PLC	Control via IEC 61131 (iPLC)
(5)	CiA 402	Control via CiA402/ EtherCat
(6)	SERCOS II	Control via SERCOS II
(7)	PROFIBUS	Control via PROFIBUS
(8)	VARAN	Control via VARAN
(9)	SERCOS III	Control via SERCOS III
(10)	TWIN	Control via TWINsync
P 0165	MPRO_REF_	Selection of reference source

P. no.	Parameter name/ Settings	Function
	SEL	
(0)	OFF	No reference selected
(1)	ANA0	Reference via analog input ISA0
(2)	ANA1	Reference via analog input ISA1
(3)	TAB	Reference via table values
(4)	PLC	Reference via PLC basic library
(5)	PLC	Reference via PLC open library
(6)	PARA	Reference via parameter
(7)	CiA 402	Reference via CiA 402
(8)	SERCOS	Reference via SERCOS
(9)	PROFIBUS	Reference via PROFIBUS
(10)	VARAN	Reference via VARAN
(11)	TWIN	Reference via TWINsync
P 0166	MPRO_Ref_ JTime	Smoothing time
P 0167	MPRO_Ref_OVR	Speed override: Reference is percentage-weighted.
P 0301	Con_Ref_Mode	Selection of interpolation mode
(0)	PG	PG(0): The reference is generated by the Profile Generator. The internal generation is executed at a sampling time of 125 ms.

P. no.	Parameter name/ Settings	Function
(1)	IP	IP(1): The reference input leads directly to the fine interpolator. Adaptation of the sampling time between the PLC and the drive controller is essential.
P 0306	CON_IpRefTS	Adaptation of sampling time between external PLC and drive controller.
P 0335	CON_SCON_ DirLock	Reversing lock for speed controller
P2243	MPRO_402_ Motion_ ProfType	Profile type PG mode
(0)	LinRamp	Linear ramp
(1)	not used	Vacant
(2)	not used	Vacant
(3)	JerkLim	Jerk-limited ramp: Effect with smoothing time set in P 0166 .
P 0370	CON_IP	Selection of interpolation method Interpolation types.htm
(0)	NoIp	No interpolation
(1)	Lin	Linear interpolation
(2)	SplneExtFF	Interpolation with external pre-control value
(3)	Spline	Cubic spline interpolation

P. no.	Parameter name/ Settings	Function
(4)	NonIPSpline	Cubic spline approximation
(5)	Cos	Cosine interpolation
P 0743	MON_ UsrPosDiffMax	Limitation of reference position change
P 0755	MPRO_FG_ RefPosFilData	Reference filter Only active in IP mode
(0)	Off	No filter active
(1)	PT1	PT1 filter with time constant
(2)	PT2	PT2 filter with time constant
P 0756	MPRO_FG_ RefPosFilData	Filter time constant
(0)	RefFil_ TimeConst	PT1/PT2 Filter time constant
(1)	RefFil_ DampConst	Damping constant

Tabelle 6.15.2 Parameters to set motion profile

6.16 Stop ramps

Each reference source has its own acceleration and braking ramps. There are also the stop ramps (quick-stop ramp), according to the CiA402 standard. The ramp functions are only effective in certain system states. The required settings can be

selected from the dialog box. Clicking the "Error/Error reactions" button directly accesses the dialog box for the error reactions.

Stop ramps in torque control

In torque control (TCON) mode too, the programmed ramps are executed in rpm on disabling the control, the reference, Halt, Quickstop and Error.



Bild 6.16.1 "Stop ramp" dialog box

Reaction to "Quickstop"

If the drive needs to be shut down as rapidly as possible due to a malfunction, it must be run down to speed zero on an appropriate ramp.

The "Quickstop" function brakes an ongoing movement differently from the normal braking ramp. The drive controller is in the ""Quickstop" system state. This state can be quit during or after braking, depending on the status of the quick-stop command and the respective reaction.

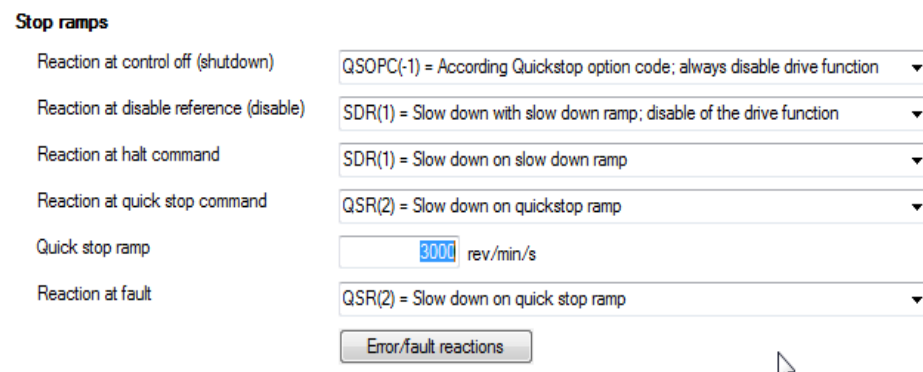
Parameters

P. no.	Parameter name Setting	Function
P2218	MPRO_402_QuickStop_OC	Quickstop option code
(0)	POFF(0) = Disable power stage/drive function	Disable power stages. The drive coasts to a stop
(1)	SDR(1) = Slow down on slowdown ramp	The drive brakes with the deceleration ramp, then the power stage is disabled.
(2)	QSR(2) = Slow down on quickstop ramp	Braking with quick-stop ramp, then the power stage is disabled.
(3)	CLIM(3) = Slow down on current limit	Braking with max. dynamism at current limit. The speed reference value is set equal to 0, then the power stage is disabled.
(4)	-	-
(5)	SDR_QS(5) = Slow down on slowdown ramp and stay in quickstop	Braking with programmed deceleration ramp. The drive remains in the quick-stop state, current is applied to the axis at zero speed. ¹⁾
(6)	QSR_QS(6) = Slowdown on quickstop ramp and stay in quickstop	Braking with quick-stop ramp. The drive remains in the quick-stop state, current is applied to the axis at speed 0. ¹⁾
(7)	CLIM_QS(7) =	Braking with max. dynamism at the

P. no.	Parameter name Setting	Function
	Slow down on current limit and stay in quickstop	current limit, the speed reference is set equal to 0. The drive remains in the quick-stop state, current is applied to the axis at speed 0. ¹⁾
(8)	-	-
¹⁾ Transition to the "Ready for start" state is only possible by resetting the quick-stop request. In the "Quick-stop" state cancelling the "Start closed-loop control/drive" signal has no effect as long as the quick-stop request is not reset as well.		

Table 6.16.2 Reaction to quick-stop

Reaction to "shutdown"

The "shutdown option code" parameter determines which action is to be executed at the transition from "Operation enable" to "Ready to Switch on" (state machine state 5 to 3).

P. no.	Parameter name Setting	Function
P2219	MPRO_402_Shutdown_OC	Shutdown option code
(-1)	QSOPC(-1) = According Quickstop option code	In the event of a Shutdown command the stop variant selected in In the event of a Shutdown command the stop variant selected in "Reaction to quick-stop" MPRO_402_QuickStop_OC .
(0)	POFF(0) = Disable power	Disable power stages; the drive coasts to a stop

P. no.	Parameter name Setting	Function
	stage/drive function	
(1)	SDR(1) = Slow down with slow down ramp; disable of the drive function	The drive brakes with the parameterized deceleration ramp down to speed zero. Then the holding brake, if fitted, engages according to its parameter setting.

Table 6.16.3 Reaction to control shutdown

Reaction to "disable Operation"

The "disable operation option code" parameter determines which action is to be executed at the transition from "Operation enable" to "Switched on" (state machine state 5 to 4).

Parameters

P. no.	Parameter name Setting	Function
P2220	MPRO_402_DisableOp_OC	Disable Operation option code
(0)	POFF(0) = Disable power stage/drive function	Disable power stages
(1)	SDR(1) = Slow down with slow down ramp; disable of the drive function	The drive brakes with the deceleration ramp, then the power stage is disabled.

Tabella 6.16.4 Reaction to "Reference disable"

Reaction to "Halt" / "Halt Operation"

The "Halt" command interrupts a movement. The drive remains in the "Operation enable" state. When the "Halt" command is cancelled the interrupted movement is completed.

Parameters

P. no.	Parameter name Setting	Function
P2221	MPRO_402_Halt_OC	Halt option code
(1)	SDR(1) = Slow down on slow down ramp	The drive brakes with the deceleration ramp
(2)	QSR(2) = Slow down on slow quickstop ramp	Braking with emergency stop ramp
(3)	CLIM(3) = Slow down on current limit	Braking with max. dynamism at current limit. The speed reference is set equal to 0.
(4)	-	-

Tabella 6.16.5 Reaction to "Halt"

Reaction to "Fault" / "FaultReaction"

P. no.	Parameter name Setting	Function
P2222	MPRO_402_	FaultReaction option code

P. no.	Parameter name Setting	Function
	FaultReaction_OC	
(1)	SDR(1) = Disabled drive, motor is free to rotate	Block power stage
(2)	QSR(2) = Slow down on slow down ramp	The drive brakes with the deceleration ramp
(3)	CLIM(3) = Slow down on current limit	Braking with max. dynamism at current limit. The speed reference is set equal to 0
(4)	-	-

Tabella 6.16.6 Reaction to "Fault"

Ramp for "Quickstop"

P. no.	Parameter name Setting	Function
P2242	MPRO_402_Quickstop_Dec_OC	Quickstop Deceleration option code

Tabella 6.16.7 "Quickstop" ramp

6.17 Homing

Homing serves to establish an absolute position reference (referred to the entire axis), and must usually be performed once after power-up. Homing is necessary when absolute positioning operations are carried out without absolute value encoders (e.g. SSI multiturn encoders). For all other positioning operations (relative, infinite) no homing is required. For zero position adjustment of absolute encoders homing method -5 is available. There are various methods, which can be set according to the application.

The selection of a homing method defines:

- the reference signal (positive limit switch, negative limit switch, reference cam)
- the direction of the drive
- the position of the zero pulse.

6.17.1 Homing dialog box

The homing movement is dictated by the speed (velocity) V1 and V2, the acceleration and the maximum positioning range.



Bild 6.17.1 Selection of homing method

Number	Meaning
1	Selection of homing methods (-12) to (35)
2	Speed V1: Speed during cam search Speed V2: Speed during zero point search
3	Acceleration for V1 and V2
4	The reference point usually has an actual position value defined on the axis side referred to the axis zero. Ideally, the position value of the drive-side datum point and of the reference point are identical. As the position of the datum point is decisively influenced by the encoder mounting, however, the datum and reference points

Number	Meaning
	differ. To establish a positional reference to the real axis zero, the desired axis-related actual position value of the reference point should be set via the zero offset.
5	Limitation of positioning range for homing. On exiting the positioning range, the axis is stopped with the error message "Overrun".

Tabelle 6.17.2 Description of dialog box

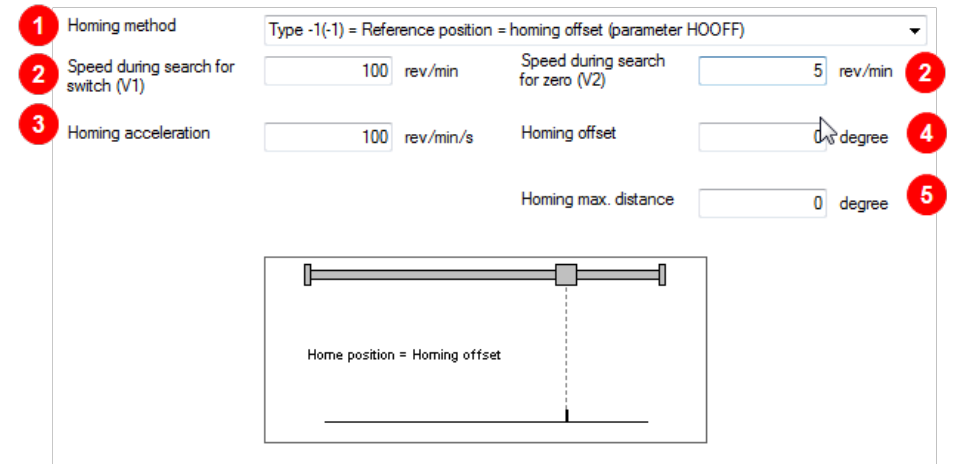

NOTE:

The reference cam signal is optionally linked to one of the digital inputs. Fast inputs ISD05 and ISD06 are available.

Homing to a limit switch:

The digital input must be set to the available selection parameter LCW(5) for a positive limit switch or to LCCW(6) for a negative limit switch.

Homing to a cam:

Set digital input to HOMSW(10) (parameters **P 0106 MPRO_INPUT_FS_ISD06** to **P 0107 MPRO_INPUT_FS_ISD07**).



NOTE:

Homing methods (-1) to (-12) are manufacturer-specific. Homing methods (0) to (35) are defined according to CiA402.

6.18 Homing method (-12)

6.18.1 Method (-12)

To set the machine reference point the rotor or linear axis is moved to the machine reference point. The desired actual position is written to the "Offset" parameter **P 2234 MPRO_402_Homeoffset**. Then the axis must be homed once. Each time the axis is restarted the absolute position is automatically calculated. Each further activation of homing resets the machine reference point at the current position.



Bild 6.18.1 Setting the machine reference point



Bild 6.19.1 Approach block, direction of travel right, with zero pulse

6.19 Homing methods (-10) and (-11)

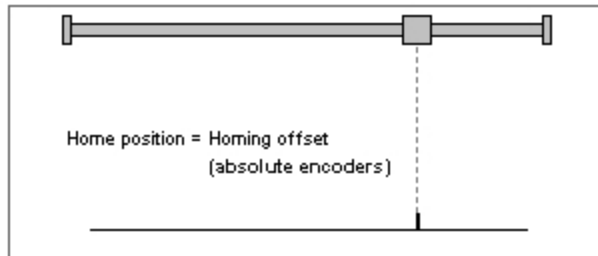
Tracking error monitoring is disabled during homing.

The maximum permissible torque can be reduced specifically during homing. To do so, parameter **P0225 MPRO_REF_HOMING_TMaxScale** is set in the range 0-100%. Note that this parameter replaces parameter **P 0332 CON_SCON_TMaxScale** during the homing run.

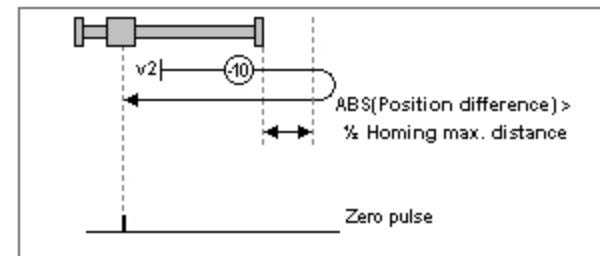
6.19.1 Method (-10)

Approach block, right with zero pulse.

With **P 0169 MPRO_REF_HOMING_MaxDistance** the positioning range in which to search for the block is specified. After approaching the block, the drive reverses the direction of rotation until a zero pulse is detected. The first zero pulse after reversing direction corresponds to the zero point. An offset can be programmed in the dialog box.

6.19.2 Method (-11)

Approach block, left with zero pulse.

With **P 0169 MPRO_REF_HOMING_MaxDistance** the positioning range in which to search for the block is specified. After approaching the block, the drive reverses the direction of rotation until a zero pulse is detected. The first zero pulse after reversing direction corresponds to the zero point. An offset can be programmed in the dialog box.



Bild 6.19.1 Approach block, direction of travel left, with zero pulse

6.20 Homing methods (-8) and (-9)

Tracking error monitoring is disabled during homing.

The maximum permissible torque can be reduced specifically during homing. To do so, parameter **P0225 MPRO_REF_HOMING_TMaxScale** is set in the range 0-100%. Note that this parameter replaces parameter **P 0332 CON_SCON_TMaxScale** during the homing run.

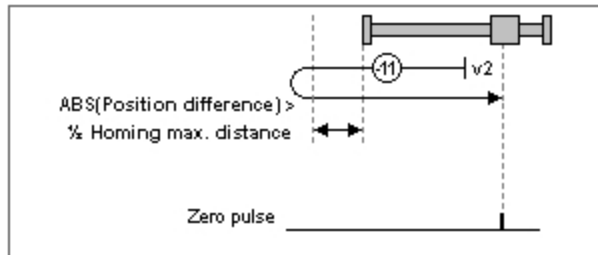
6.20.1 Method (-8)

Approach block, right.

With **P 0169 MPRO_REF_HOMING_MaxDistance** the tracking error is specified in the positioning range in which the block is detected. When the block is detected, the system disengages by half the value in parameter **P 0169 MPRO_REF_HOMING_MaxDistance**) and the zero point is defined. An offset can be programmed in the dialog box.



Bild 6.20.1 Approach block, direction right

6.20.2 Method (-9)

Approach block, left.

With **P 0169 MPRO_REF_HOMING_MaxDistance** the tracking error is specified in the positioning range in which the block is detected.

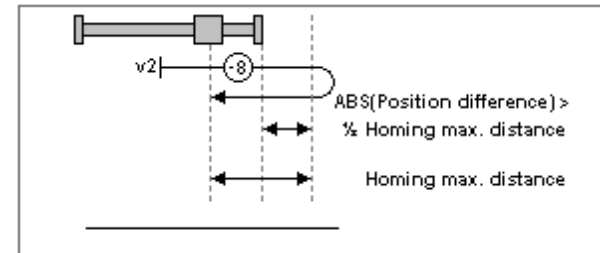
When the block is detected, the system disengages by half the value in parameter **P 0169 MPRO_REF_HOMING_MaxDistance**) and the zero point is defined.

An offset can be programmed in the dialog box.



Bild 6.20.1 Approach block, direction left

6.21 Homing methods (-7) to (0)

6.21.1 Homing method for increment-coded encoders

- Method (-6): Movement in negative direction
- Method (-7): Movement in positive direction

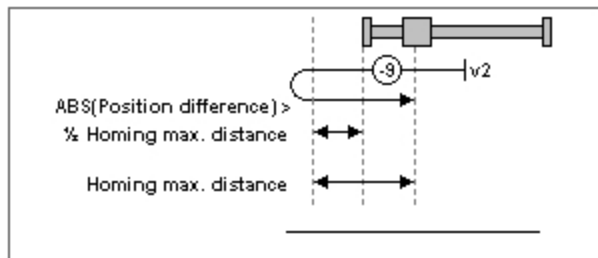
[Increment-coded reference marks.htm](#)

6.21.2 Method (-5) Absolute encoder

These homing methods are suitable for absolute encoders (e.g. SSI-Multiturn encoders). Homing is performed immediately after power-on. The reference position is calculated on the basis of the encoder absolute position plus zero offset. In the case of a SSI multi-turn encoder, homing with zero point offset = 0 gives the absolute position of the SSI encoder. Another homing run with unchanged setting of the zero offset does not cause a change in position.

To set the machine reference point homing method (-12) should be used.

6.21.3 Methods (-4) and (-3) are not defined

6.21.4 Method (-2) No homing

No homing is performed. The current position is added to the zero offset. The first time the power stage is switched on the "Homing completed" status is set. This method is suitable for absolute encoders, as long as no offset compensation is required. For offset compensation select method (-5).

6.21.5 Method (-1) Actual position = 0

The actual position corresponds to the zero point; it is set to 0, meaning the controller performs an actual position reset. The zero offset is added.

6.22 Homing methods 1 and 2: Limit switch and zero pulse

6.22.1 Method 1: Negative limit switch and zero pulse

- Start movement left; at this time the hardware limit switch is inactive.
- The direction of movement reverses on an active hardware limit switch edge.
- First zero pulse after falling limit switch edge corresponds to zero/reference point.



Bild 6.22.1 Negative limit switch and zero pulse

6.22.2 Method 2: Positive limit switch and zero pulse

- Start movement right; at this time the hardware limit switch is inactive.
- The direction of movement reverses on an active hardware limit switch edge.
- First zero pulse after falling limit switch edge corresponds to zero/reference point.

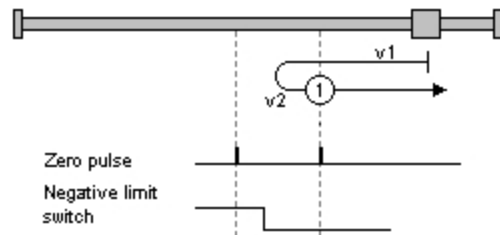

Bild 6.22.1 Positive limit switch and zero pulse

6.23 Homing methods 3 and 4: Positive reference cam and zero pulse

6.23.1 Method 3: Start movement in direction of positive (right) hardware limit switch

- Start movement in direction of positive (right) hardware limit switch; at this time the reference cam is inactive.
- The direction of movement reverses on an active reference cam edge.
- First zero pulse after falling cam edge corresponds to zero/reference point.

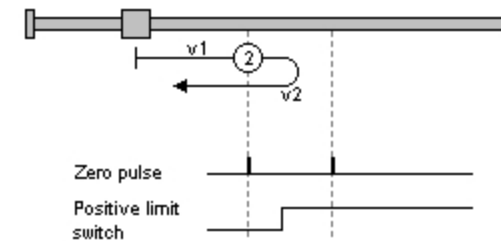

Bild 6.23.1 Start condition for positive limit switch

6.23.2 Method 4: Start movement in direction of negative (left) hardware limit switch

- Start movement in direction of negative (left) hardware limit switch; at this time the reference cam is inactive.
- The direction of movement reverses on an active reference cam edge.
- First zero pulse after falling cam edge corresponds to zero/reference point.

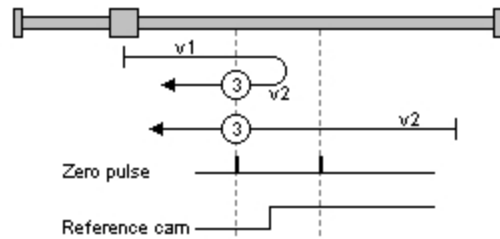

Bild 6.23.1 Start condition for negative limit switch

6.24 Homing methods 5 and 6: Negative reference cam and zero pulse

6.24.1 Method 5: Start movement in direction of positive (right) hardware limit switch with zero pulse

- Start movement in direction of positive (right) hardware limit switch; at this time the reference cam is active.
- First zero pulse after falling cam edge corresponds to zero/reference point.
- The direction of movement reverses on an active reference cam edge.
- Start movement in direction of negative limit switch if reference cam is inactive.

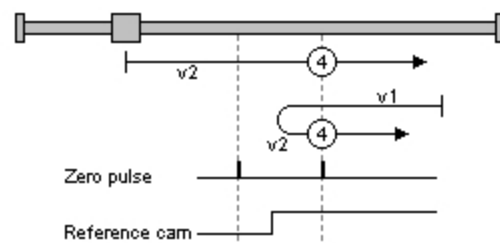

Bild 6.24.1 Positive (right) hardware limit switch and zero pulse

6.24.2 Method 5: Start movement in direction of negative (left) hardware limit switch with zero pulse

- Start movement in direction of negative (left) hardware limit switch.
- The direction of movement reverses on an inactive reference cam edge.
- First zero pulse after rising cam edge corresponds to zero/reference point.

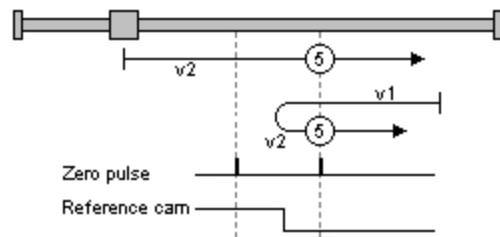

Bild 6.24.1 Negative (left) hardware limit switch and zero pulse

6.25 Homing methods 7 to 10:

6.25.1 Method 7: Reference cam, zero pulse and positive limit switch

- The start movement is in the direction of the positive (right) hardware limit switch. It and the reference cam are inactive.
- The direction is reversed after an active reference cam. The zero corresponds to the first zero pulse after a falling edge.
- The start movement is in the direction of the negative (left) hardware limit switch. The reference point is set at the first zero pulse after a falling reference cam edge.
- The first zero pulse after overrunning the reference cam corresponds to the zero point.

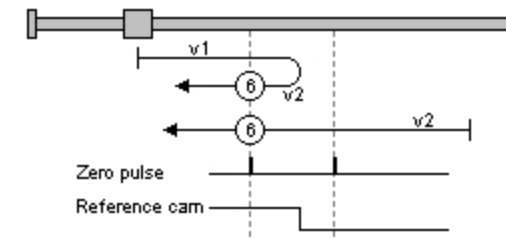

Bild 6.25.1 Reference cam, zero pulse and positive limit switch

6.25.2 Method 8:

- The zero corresponds to the first zero pulse with an active reference cam.
- At a falling reference cam edge the direction changes. The zero point corresponds to the first zero pulse after the rising edge of the reference cam.
- The direction reverses if the reference cam has been overrun. The zero corresponds to the first zero pulse after the rising edge.

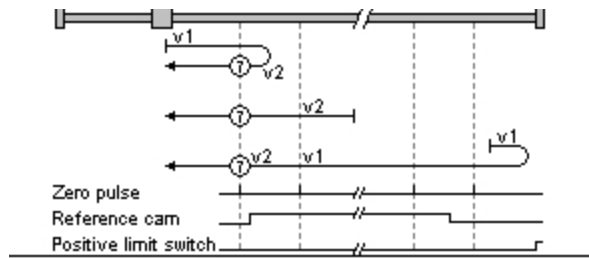

Bild 6.25.1 Zero point corresponds to first zero pulse

6.25.3 Method 9:

- The direction changes when the reference cam becomes inactive. The zero corresponds to the first zero pulse after the rising edge.
- The zero corresponds to the first zero pulse with an active reference cam.

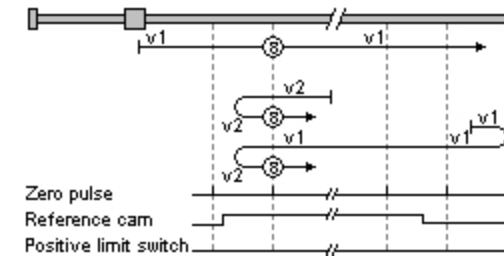

Bild 6.25.1 Direction changes when reference cam becomes inactive

6.25.4 Method 10:

- The reference cam is overrun and the first zero pulse after the falling edge corresponds to the zero point.
- After a falling reference cam edge: The first zero pulse corresponds to the zero point.
- After an active reference cam: The zero corresponds to the first zero pulse after a falling edge.

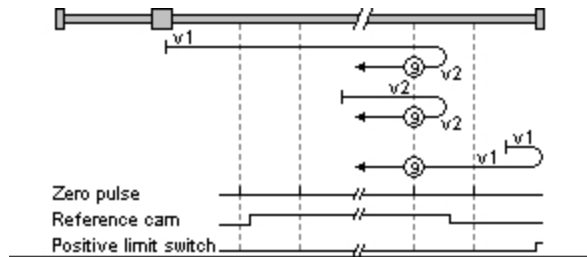

Bild 6.25.1 Zero pulse after falling edge corresponds to zero point.

6.26 Homing methods 11-14: Reference cam, zero pulse and negative limit switch

6.26.1 Method 11

- Reverse direction after active reference cam. The zero corresponds to the first zero pulse after a falling edge.
- Zero at first zero pulse after falling edge of reference cam.

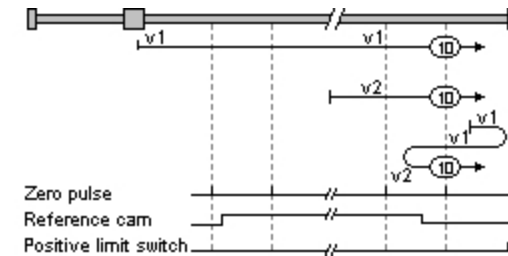
- The reference cam must be overrun, then the first zero pulse corresponds to the zero.



Bild 6.26.1 Reverse direction after active reference cam

6.26.2 Method 12

- Zero corresponds to first zero pulse with active reference cam.
- Reverse direction after falling reference cam edge. The zero point corresponds to the first zero pulse after the rising edge of the reference cam.
- Reverse direction when reference cam has been overrun. The zero corresponds to the first zero pulse after the rising edge.

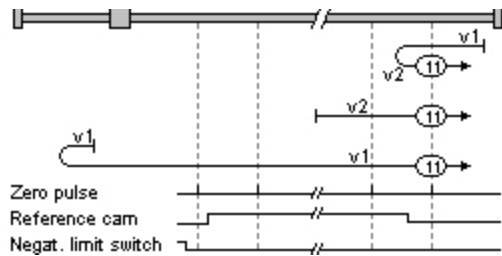

Bild 6.26.1 Zero point corresponds to first zero pulse.

6.26.3 Method 13

- Reverse direction when reference cam has been overrun. The zero corresponds to the first zero pulse after the rising edge.
- Reverse direction when reference cam becomes inactive. The zero corresponds to the first zero pulse after the rising edge.
- Zero corresponds to first zero pulse with active reference cam.

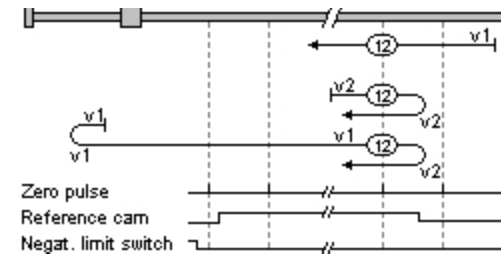

Bild 6.26.1 Reverse direction...

6.26.4 Method 14

- Zero corresponds to first zero pulse after running over reference cam.
- Zero corresponds to first zero pulse after falling edge of reference cam.
- Reverse direction after active reference cam. The zero corresponds to the first zero pulse after a falling edge.

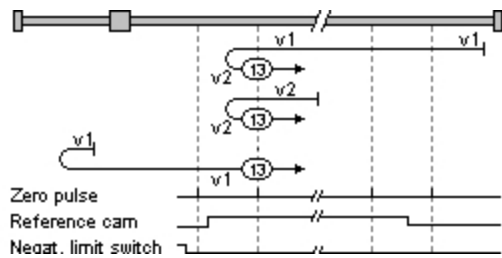

Bild 6.26.1 Zero point corresponds to first zero pulse after...

6.27 Homing methods 15 and 16

The two homing methods are not defined.

6.28 Homing methods 17-30: Reference cam

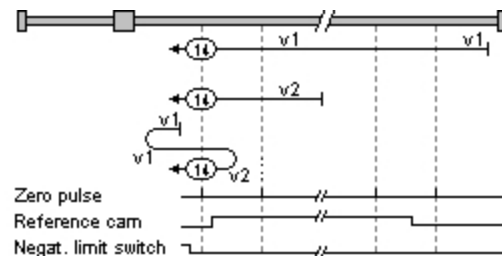
6.28.1 Method 17-30

The homing method types 17 to 30 are equivalent to types 1 to 14. Definition of the reference point is independent of the zero pulse. It depends only on the cam or on the limit switches.



Bild 6.28.1 Homing methods 17 to 30 are equivalent to methods 1 to 14

Method 1 corresponds	Definition of the reference point is independent of the
----------------------	---

to method 17	zero pulse. It depends only on the cam or on the limit switches.
Method 4 corresponds to method 20	
Method 8 corresponds to method 24	
Method 12 corresponds to method 28	
Method 14 corresponds to method 30	

Tabelle 6.28.2 Comparison of homing methods

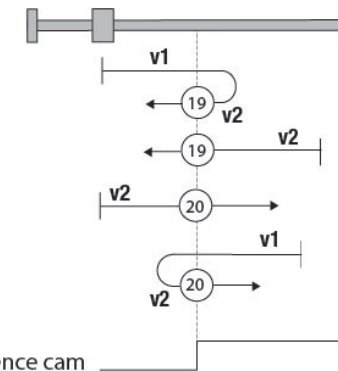
6.29 Homing methods 31 and 32

The two homing methods are not defined.

6.30 Homing methods 33 and 34: With zero pulse

6.30.1 Method 33: Direction left:

The zero pulse corresponds to the first zero pulse to the left.



Bild 6.30.1 Homing with zero pulse

6.30.2 Method 34: Direction right:

The zero pulse corresponds to the first zero pulse to the right.

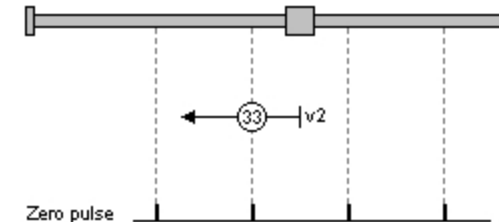

Bild 6.30.1 Homing with zero pulse

6.31 Homing method 35

6.31.1 Method 35

The actual position corresponds to the reference point.

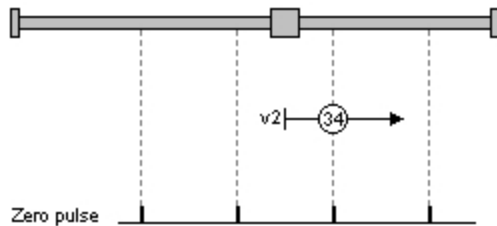

Bild 6.31.1 The actual position corresponds to the reference point.

6.32 Jog mode

This function is selected via the project tree in the "Motion profile" subject area, Jog mode. Jog mode (setup mode) is used to record (teach-in) positions, for disengaging in the event of a fault, or for maintenance procedures. A bus system or reference sourcing via terminal can be selected as the reference. The unit corresponds to the selected user unit. Two speeds are available for both directions. If the drive is to be moved at different speeds, both inputs must be active (relevant bits in bus operation). If the "Jog left" input is activated first and then input two, "Fast jog mode left" is started. If the "Jog right" input is activated first, "Fast jog mode right" is started.

Jog mode setting

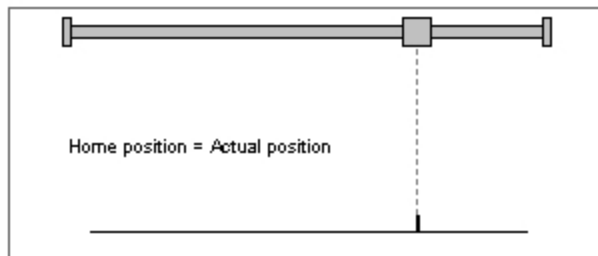
- Jog in positive and negative direction:
Set two digital inputs
ISD0x = INCH_P (7) = jog +
ISD0x = INCH_N (8) = jog-
- **Fast jog:**
Both digital inputs must be active (corresponding bits in bus mode)
- **Fast jog direction left:**
Activate "Jog left" input and then additionally input two
- **Fast jog direction right:**
Activate "Jog right" input and then additionally input two

Setting of jog speed via project tree – Jog mode



Bild 6.32.1 "Jog mode" dialog box

Setting the necessary digital inputs

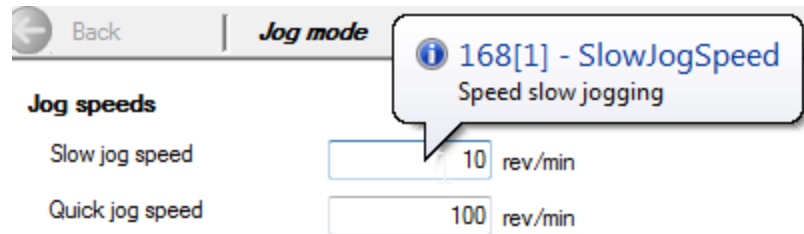

Bild 6.32.2 "Digital inputs" dialog box
Manual mode window, "Jog mode" tab

The jog speeds in the manual mode window are oriented to the values of the "Jog mode speed settings" dialog box. The drive is moved using the "Jog -" and "Jog +" buttons.

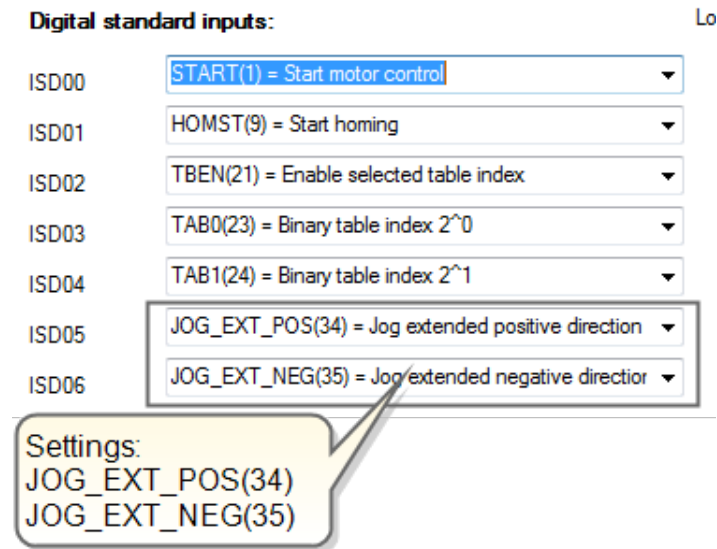

Bild 6.32.3 "Jog mode" window

6.33 Electronic gearing settings

6.33.1 Electronic gearing / Synchronized movement

By way of the "Synchronized movement" motion profile the setup dialog box opens up. "Electronic gearing". In it the gear transmission ratio, the pre-control scaling and the engagement and disengagement mode are specified. The transmission ratio (gear ratio) is given in fractions.

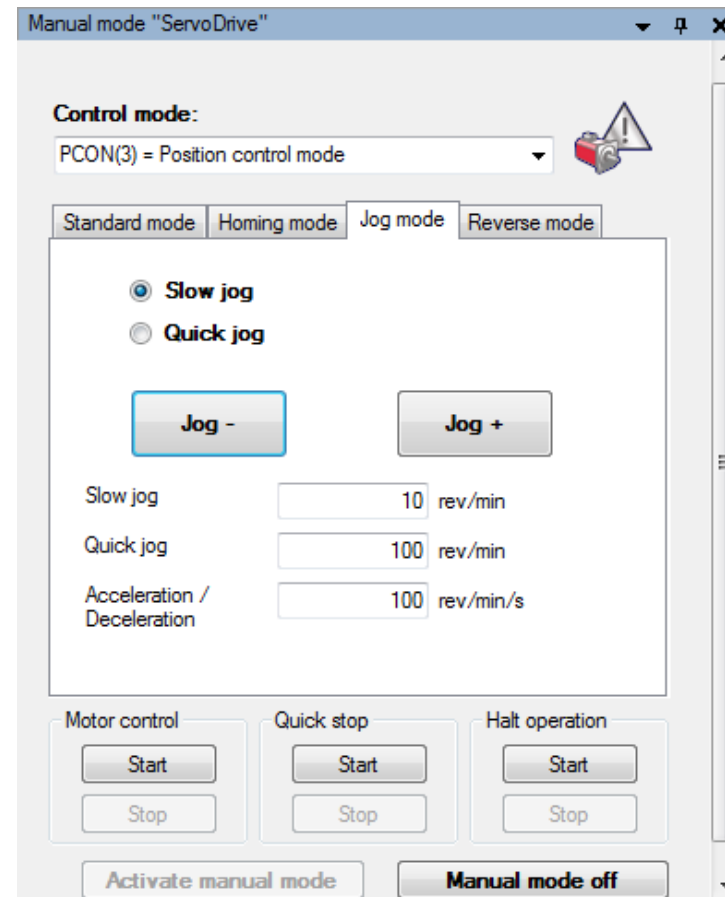
This ensures that the position references can be translated to the motor shaft with no rounding error.

Speed factor:

Scaling of speed pre-control

Torque factor:

Scaling of torque pre-control

Engagement/disengagement mode:

Described in the "Engagement and disengagement" topic.



Bild 6.33.1 "Electronic gearing" dialog box

6.34 Master configuration

6.34.1 Specifying the master encoder:

The master encoder may be a "virtual master", a higher-level PLC, or an encoder system. The channels for the encoder system to be used are selected from the list box. Channel 3 is only available if an external interface X8 (option module) is present. If a higher-level PLC is used as the master encoder **P 1319 MPRO_ECAM_CamMaster_Axis_Type = PARA(2)**, the resolution must be set referred to one motor revolution **P 0250 MPRO_ECAM_PARAMaster_Amplitude**.

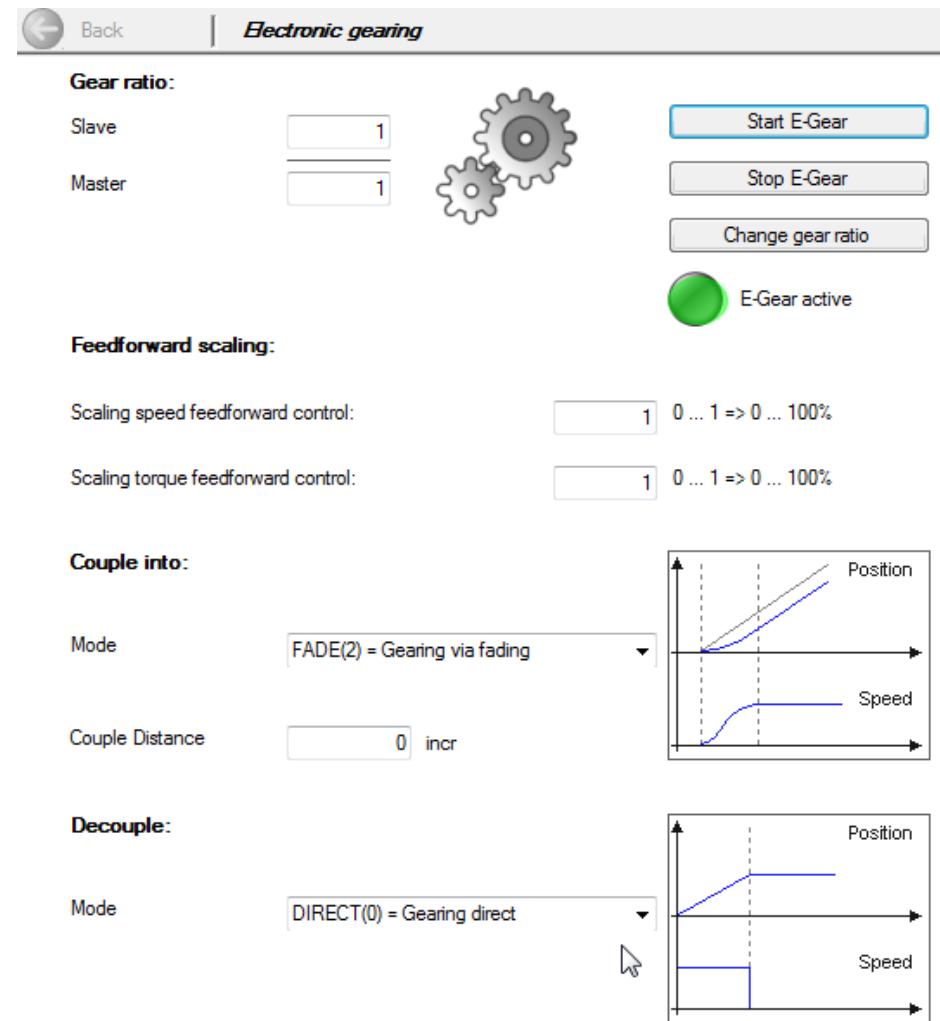
Master configuration:

Channel selection (master encoder) PARA(2) = Parameter interface master Options...

Anti reverse mode INACTIVE(0) = Reverse lock inactive

Filter type PT1(1) = PT1 filter

Filter time 21 ms

Speed factor 1
0 ... 1 => 0 ... 100%

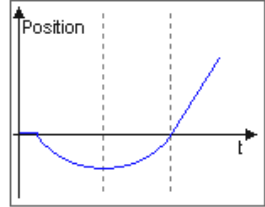

Parameterinterface master:

Position resolution master Inc/U 2^16 incr(16) =

Bild 6.34.1 Master configuration Channel selection

Parameters

P. no.	Parameter name Setting	Function
P1319	MPRO_ECAM_CamMaster_AxisType	Selection of master encoder
(0)	No Axis	Master encoder selected
(1)	Virtual Master	Virtual master
(2)	PARA	Parameter interface

P. no.	Parameter name Setting	Function
(3)	ENC CH1	Encoder on channel 1
(4)	ENC CH2	Encoder on channel 2
(5)	ENC CH3	Encoder on channel 3

Tabelle 6.34.2 Channel selection

Anti-reverse mode

[Anti-reverse mode.htm](#)

P. no.	Parameter name Setting	Function
P1320	MPRO_ECAM_ CamMaster_ RevLockMode	Anti-reverse mode
(0)	INACTIVE	Anti-reverse mode inactive
(1)	ACTIVE with waycompensation	Anti-reverse mode with path compensation: While the slave accelerates to the speed of the master during engagement, the master and slave do not move synchronously. To catch up the advancing master, select the "path-compensated" function.
(2)	ACTIVE without waycompensation	Anti-reverse mode without path compensation

Tabelle 6.34.3 Anti-reverse mode setting

Filter type for guide value

When using a real master encoder, encoder signals may be subject to noise. The signals can be filtered with a PT1 element or a mean value filter



Bild 6.34.4 Selection window for filter

Parameters

P. no.	Parameter name Setting	Function
P1340	MPRO_ECAM_CamMaster_SpeedFilTyp	Selection of filter type
(0)	OFF	Not active
(1)	PT1	PT1 Filter
(2)	AVG	Mean value filter

Tabelle 6.34.5 Selection of a suitable filter for noise suppression

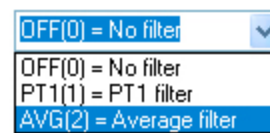
Speed

The master encoder can be assigned an additional speed factor.



Bild 6.34.6 Speed factor input window

Parameter Master

When using the "Parameter Master", the number of increments per motor revolution **P 0250 MPRO_ECAM_ParaMaster_Amplitude** must be set.

[Siehe "Anti-reverse mode" auf Seite 168](#)

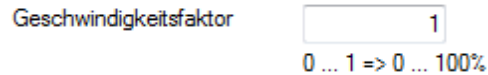
6.35 Engagement and disengagement

Engagement variants

P. no.	Parameter name Setting	Figure	Function
P 0253	MPRO_ECAM_Egear_GearIn_MOD	Master = black curve Slave = blue curve Engagement distance (dotted line)	Engage mode

P. no.	Parameter name Setting	Figure	Function
(0)	Direct		Direct engagement: - angle-synchronous - collisional (no ramps)
(1)	ramp		Engagement with linear acceleration profile: - not angle-synchronous - jerked
(2)	fade		Engagement with fade-in function (5th order polynomial): - not angle-synchronous - jerk limited - The position is ignored. There always remains a variation between reference and actual position.

P. no.	Parameter name Setting	Figure	Function
(3)	crossfade		Engage with cross-fade function (5th order polynomial) - angle-synchronous - jerk limited - Speed overshoots during engagement.
P 0255	MPRO_ECAM_Egear_GearIn_Acc		Acceleration ramp
P 0257	MPRO_ECAM_Egear_GearIn_Dist		Engagement distance: The actual engagement takes place within the engagement distance (dotted line).

Tabelle 6.35.1 Engagement variants

Disengagement variants

P. no.	Parameter name Setting	Figure	Function
P 0254	MPRO_ECAM_	Master = black curve	Disengage mode

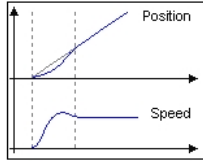

P. no.	Parameter name Setting	Figure	Function
	Egear_GearOut_MOD	Slave = blue curve Engagement distance (dotted line)	
(0)	Direct		Direct disengagement: - collisional (no ramps)
(1)	ramp		Disengagement with linear acceleration profile: - jerked
(2)	fade		Disengagement with fade-out function (5th order polynomial) : - jerk limited
P 0256	MPRO_ECAM_Egear_GearOut_Acc		Braking ramp
P 0258	MPRO_ECAM_Egear_GearOut_Dist		Disengagement distance: - collisional (no ramps)

Tabelle 6.35.2 Engagement mode

NOTE:  The actual engagement takes place within the engagement distance (dotted line). This area can be set separately for acceleration and braking.

6.36 Anti-reverse mode

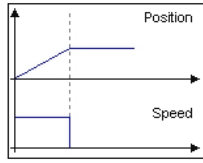
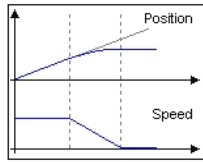
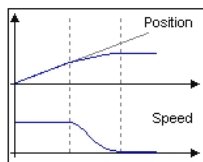
Anti-reverse mode can be used optionally with or without path compensation. The table explains how the master and slave respond when path compensation is selected or not. The selection options are explained in the table.

P. no.	Parameter name Setting	Figure	Function
P1312	MPRO_ ECAM_ CamMaster_ RevLock_ Mode	Master = black curve Slave = blue curve Engagement distance (dotted line)	Selection of anti-reverse mode

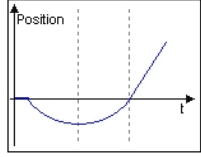
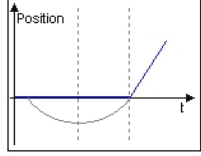
P. no.	Parameter name Setting	Figure	Function
(0)	INACTIVE		Anti-reverse mode inactive: The slave follows the master directly and in every direction.
(1)	ACTIVE with WAY COMP		Anti-reverse mode with path compensation: <ul style="list-style-type: none"> • Master rotates in the blocked direction again • Slave stays still • Master rotates in the unblocked direction. • Slave only starts moving along with it again as soon as the master reaches the zero position. Example: If the master, which

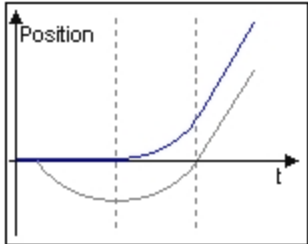
P. no.	Parameter name Setting	Figure	Function
			has moved two motor revolutions in the direction blocked for the slave, then moves in the unblocked direction again, the slave only moves off when the master has traversed the zero point.
(2)	ACTIVE without WAY COMP		<p>Anti-reverse mode without path compensation:</p> <ul style="list-style-type: none"> • Master rotates in the blocked direction • Slave stays still • Master rotates in the unblocked direction again. • The slave follows the master directly in the unblocked direction.

P. no.	Parameter name Setting	Figure	Function
			<p>Example:</p> <p>If the master, which has moved two motor revolutions in the direction blocked for the slave, then moves in the unblocked direction again, the slave moves off immediately in the unblocked direction.</p>

Tabelle 6.36.1 Setting for anti-reverse mode

[Master configuration.htm](#)

6.37 Synchronization mode

The Synchronized Movement function enables synchronous running of the drive in relation to a real or virtual master axis.

Digital control signals are used to provide positionally precise disengagement from the guide value (e.g. with standstill at cycle end) and positionally precise engagement to the current guide value.

An encoder system, the virtual master or the parameter interface is selected as

the master encoder in the master configuration.
 By setting the parameter interface to a bus system (Basic setting Control and Reference) control is programmed via a bus system (control word **P 1318 MPRO_ECAM_ControlWord**, status word **P 1326 MPRO_ECAM_StatusWord**).

Selection "Electronic gearing"

Synchronized motion:

Mode of synchronized motion

Bild 6.37.1 Selection of synchronization mode

Gear ratio:

Slave
 Master



E-Gear active

Feedforward scaling:

Scaling speed feedforward control: 0 ... 1 => 0 ... 100%

Scaling torque feedforward control: 0 ... 1 => 0 ... 100%

Couple into:

Mode

Couple Distance incr

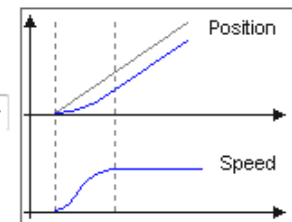

Decouple:

Mode



Bild 6.37.2 "Electronic gearing" dialog box

Parameters

P. no.	Parameter Setting	Function
P 0242	MPRO_RECAM_SyncMod	Mode selection
(0)	OFF	No mode selected
(1)	ECAM_iPlc	Activation of cam plate via iPlc
(2)	EGEAR_iPlc	Activation of electronic cam plate via iPlc.
(3)	ECAM PARA	Cam plate via parameter
(4)	EGEAR PARA	Electronic gearing via parameter.

Table 6.37.3 Selection of synchronization mode.

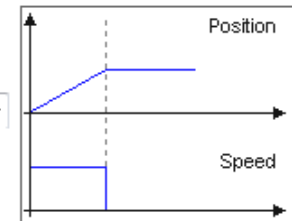
Transmission ratio (gearing factor):

The ratio is given as a fraction. This ensures that the position on the drive shaft can be translated onto the motor shaft without rounding errors at any time.

Speed factor:

Scaling of speed pre-control

Torque factor:

Scaling of torque pre-control

6.38 Status and control word

6.38.1 Control word for electronic gearing

P 1318 MPRO_ECAM_ControlWord.

Bit number	Function	iPLC function
0-7	Start segment (8-bit value)	-
8-15	Reserve	-
16	Absolute (true) / relative (false) master relationship	-
17	Absolute (true) / relative (false) master (CAM) relationship at cam in	-
18	Absolute (true) / relative (false) slave (CAM) relationship at cam in	-
19-23	Reserve	-
24	Change gear ratio of the electronic gear online	MCB_GearRatioChange
25	Disable master calculation	MCB_Cam_MasterEnable
26	Enable master calculation	MCB_Cam_MasterEnable
27	Select CAM table	MCB_CamTableSelect

Bit number	Function	iPLC function
28	Start Ecam	MCB_CamIn
29	Stop Ecam	MCB_CamOut
30	Start Egear	MCB_GearIn
31	Stop Egear	MCB_GearOut

Tabelle 6.38.1 Control word ECAM

Bit number	Description
28	Valid segments chosen
29	Master data are valid
30	Master is initialized
31	Master calculation is active

Tabelle 6.38.1 Status word ECAM

6.38.2 Status word for electronic gearing

P 1326 MPRO_ECAM_StatusWord

Bit number	Description
0-7	Actual segment (8-bit value)
8-11	Actual ECAM / EGEAR state machine state (4-bit value) 0: ECAM / EGEAR asynchronous 1: ECAM / EGEAR synchronous 2: ECAM / EGEAR synchronizing 3: ECAM / EGEAR desynchronizing 4: ECAM / EGEAR active and waiting for going asynchronous 5: ECAM / EGEAR inactive and waiting for going synchronous
12-26	Reserve
27	ECAM / EGEAR is active

6.39 Virtual Master

If the "Virtual master" is selected for the master encoder, the dialog box below opens up under "Options". Click "Start" to start the engagement and click "Stop" and "Halt" correspondingly to stop it.

Virtual Master:

Speed	<input type="text" value="500"/>	rpm
Amplitude	<input type="text" value="1048576"/>	incr/rev
Acceleration	<input type="text" value="0"/>	rpm/s
Deceleration	<input type="text" value="0"/>	rpm/s
Jerk	<input type="text" value="0"/>	rpm/s ²

Status: READY

Actual speed: 0 rpm

Actual position: 0 incr

Bild 6.39.1 "Virtual master" dialog box



NOTE:

The virtual master must be activated by clicking the "Start" button, and remains active for operation of a synchronized movement.

6.40 Cam plate

The function is not available as standard. It must be specially requested. Contact LTI DRIVES GmbH.

6.41 Reference table

6.41.1 Reference table setting

With the reference table up to 16 reference values can be defined. In the process, the drive moves to its targets in conformance to the respective driving sets. Depending on the selected control mode, each reference in the table assigned a speed, acceleration and deceleration value. The table reference values can be used in any control mode.

Control mode: AUTO(2) = via time delay (parameter no. 204)

	0	1
Reference	3600 degree	-3600 degree
Mode	REL(1) = Relative (after target reach)	REL(1) = Relative (after target reach)
Speed	50 rev/min	3000 rev/min
Acceleration	1000 rev/min/s	1000 rev/min/s
Deceleration	1000 rev/min/s	1000 rev/min/s

Time delay in Auto mode: 0 ms

Max. table index in Auto mode: 3

Actual table index: 0

Teach position

Bild 6.41.1 Reference table

Scaling

The references must be made available in user-defined distance units. This is done by way of the "Scaling" motion profile.

Speed

In "Infinite positioning" mode the speed can be specified signed. It is limited by parameter P 0328 CON_SCON_SMax.

Ramps

The acceleration values for starting and braking can be parameterized irrespective of each other. The input must not be zero.

Positioning jobs

The driving jobs from zero up to the value set in "Number of follow-up jobs to be processed" are continuously processed. When the driving set entered in **P 0206 MPRO_TAB_MaxIdx** is complete, the first data set restarts. For this, **P 0205 MPRO_TAB_Mode** must be set to = **"AUTO"**. Processing is only stopped by removing the start contact. The positioning mode **P 0203 MPRO_TAB_PMode = "REL at once"** aborts a current position driving set and moves, as from the current position, to the new reference.

Parameters

P. no.	Parameter name / Setting	Function
P 0193	MPRO_TAB_TAcc	Acceleration ramp (torque)
P 0194	MPRO_TAB_TDec	Braking ramp (torque)

P. no.	Parameter name / Setting	Function
P 0195	MPRO_ TAB_TRef	Reference (torque)
P 0196	MPRO_ TAB_SAcc	Acceleration ramp (speed)
P 0197	MPRO_ TAB_SDec	Braking ramp (speed)
P 0198	MPRO_ TAB_SRef	Reference (speed)
P 0199	MPRO_ TAB_PAcc	Acceleration ramp (position)
P 0200	MPRO_ TAB_PDec	Braking ramp (position)
P 0201	MPRO_ TAB_PSpd	Speed (position)
P 0202	MPRO_ TAB_PPos	Position reference
P 0203	MPRO_ TAB_PMode	Positioning mode
(0)	ABS(0)	Absolute positioning
(1)	REL(1)	Relative positioning after target position reached
(2)	REL at once (2)	The current driving job is interrupted and a new pending job is directly accepted and executed.

P. no.	Parameter name / Setting	Function
(3)	SPEED(3)	Infinite motion, SPD (infinite driving job): If a table value is set to SPD, an infinite driving job is transmitted. If a table value with the setting ABS or REL is additionally selected, the infinite job is quit and the newly selected table value is approached from the current position.
P 0204	MPRO_ TAB_Wait time	In case of follow-up jobs: Wait time until execution of the next driving job.
P 0205	MPRO_ TAB_Mode	Control source
(0)	PARA (0)	Selection of a table value via P 0207 MPRO_TAB_ActIdx
(1)	TERM(1)	Selection of a table value via the digital inputs
(2)	AUTO (2)	Automatic processing of follow-up driving jobs. The number of driving jobs entered in parameter P 0206 MPRO_Tab_MaxIdx is processed in sequence. This operation is repeated until the drive is stopped or the table is disabled.
(3)	BUS(3)	Selection of a table value via PROFIBUS. No other field bus systems are implemented.
P 0206	MPRO_Tab_MaxIdx	The number of driving jobs set here is processed in sequence. This operation is repeated until the drive is stopped or the table is disabled.
P 0207	MPRO_	Display of the currently selected driving job. If

P. no.	Parameter name / Setting	Function
	TAB_ActIdx	parameter P 0205 MPRO_TAB_Mode is set to = Para(0) , a driving set can be entered and approached directly.

Table 6.41.2 Parameters – table references

Vorgehensweise: Enabling table values:

Settings for reference input via table values

Activation	Setting	Function
Actuation via digital inputs	Input ISDxx = TBEN	Enable a selected driving set. The selection of a new driving job always interrupts an ongoing positioning and the follow-up job logic.
Actuation via digital inputs	Input ISDxx = TAB0 to TAB3	The binary significance ($2^0, 2^1, 2^2, 2^3$) results from the TABx assignment. The setting TAB0 has the lowest significance (2^0) and TAB3 the highest (2^3). A high level on the digital input activates the corresponding driving set.
Triggering via field bus system	Enable "Execute driving job" bit.	Enable a selected driving set. The selection of a new driving job always interrupts an ongoing positioning and the follow-up job logic.
Triggering via field bus	"Activate follow-up job" bit	The binary significance ($2^0, 2^1, 2^2, 2^3$) results from the TABx assignment of the control word. The setting TAB0 has the lowest significance (2^0) and TAB3 the

Activation	Setting	Function
system		highest (2^3).

Table 6.41.3 Activation of table references

6.42 Analog channel

6.42.1 Settings

Two standard analog inputs ISA00, ISA01 are available. The negative indices are set for analog reference input, and the positive indices for digital reference processing. The option REV(-2) = Analog command specifies an analog voltage of +/- 10 V.



Bild 6.42.1 Reference processing

Analog standard inputs:

ISA00
 Function: REFV(-2) = Analog command
 ISA00 filter time: (-8) -(-8) = Not defined, (-7) -(-7) = Not defined, (-6) -(-6) = Not defined, (-5) -(-5) = Not defined

ISA01
 Function: REFV(-2) = Analog command
 ISA01 filter time: (1) -(-1) = Not defined, OFF(0) = No function, START(1) = Start motor control, INV(2) = Inverse reference value, STOP(2) = Stop motor

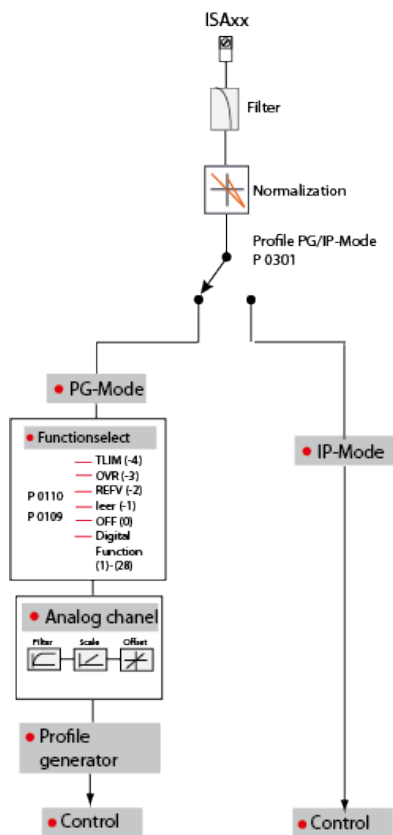
Scaling
 10 V correspond to: 4500 degree
 Offset (O): 0 degree
 Backlash (B): 30 degree

Motion profile
 Speed: 1500 rev/min
 Acceleration: 1000 rev/min/s

The graph shows a linear relationship between [Value] and [V]. The x-axis ranges from -10V to +10V. A blue arrow points from the scaling settings to the graph.

Bild 6.42.2 Standard analog inputs

- Assignment: +/- 10 V corresponds to the maximum reference value (e.g. 3000 rpm).
- Component spread can be compensated by way of the offset function.
- The backlash setting can be used to suppress movement of the axis in the standstill range.
- The setting for specifying torque references is made via the analog channel, as in speed control.
- Braking/acceleration ramp for torque and speed

6.42.2 Position reference input via analog channel

With the analog inputs ISA00 or ISA01 absolute position references can be specified for position control. The connected input voltage is assigned to the maximum position reference value by means of a scaling factor in the range ± 10 V. Setting a position offset can be compensated for component variations. A threshold value can also be specified which generates a run-on range around the last reference value. A ramp function calculates a motion profile for the position reference from pre-defined acceleration and speed limits.

The position references on the analog channel are not applied immediately, but dependent on a digital input. For this, one of the digital inputs ISD00 to ISD06 must be parameterized to the value REFANAEN(28). The received position reference is only applied when the corresponding digital input is TRUE. The acceleration is entered in parameter **P 0173[0] MPRO_ANA0_TScale** or **P 0183[0] MPRO_ANA1_TScale**.

Parameters

P. no.	Parameter name Setting	Function
P 0173 P 0183	Scaling factor	Scaling
(0)	MPRO_ANAX_TScale	Scaling of torque reference
(1)	MPRO_ANAX_SScale	Scaling of speed reference
(2)	MPRO_ANAX_PScale	Scaling of position reference
P 0174 P 0184	Offset	
(0)	MPRO_ANAX_TOffset	Torque reference offset
(1)	MPRO_ANAX_SOffset	Speed reference offset

P. no.	Parameter name Setting	Function
(2)	MPRO_ANAX_POffset	Position reference offset
P 0175/ P 0185	Backlash	
(0)	MPRO_ANAX_TThreshold	Torque reference backlash
(1)	MPRO_ANAX_SThreshold	Speed reference backlash
(2)	MPRO_ANAX_PThreshold	Position reference backlash
P 0176 P 0186	Acceleration/braking ramp for torque	
(0)	MPRO_ANAX_TRamp	Speed acceleration ramp
(1)	MPRO_ANAX_TRamp	Speed braking ramp
P 0177/ P 0187	Acceleration/braking ramp for speed	
(0)	MPRO_ANAX_SRamp	Speed acceleration ramp
(1)	MPRO_ANAX_SRamp	Speed braking ramp
P 0405/ P 0406	CON_ANA_filtx	Filter time (0-100 ms)

Tabelle 6.42.1 Reference processing, analog inputs ISA00, ISA01

Setting



- Function selector **P 0109/P 0110: MPRO_INPUT_FS_ISA00/ISA01= REFV (-2)**
- Reference processing via PG/IP mode (see also Profile generator)
- Analog channel setting:
 - Select input function
 - Scaling
 - Voltage offset [V]
 - Filter time
- Set acceleration/braking ramps, stop ramps

6.43 State machine

6.43.1 State machine according to CiA402

The system state of the drive is basically managed by the central state machine according to CiA402. However, the transitions and states which the state machine passes through are dependent on the drive profile setting and the bus system used. During operation, a distinction is made between drive standstill, operation, and the error states.

States display

Display	System state
	Initialization on device startup
	Not ready (DC link voltage possibly too low)
	Start inhibit (DC link voltage present, power stage off)









Display	System state
	Starting lockout
	Ready for start
	Control initialization: Autocommutation, flux build-up, etc.
	Control enabled
	Quick-stop active
	Error reaction active
	Error state (in this state the error is indicated directly on the display.)
	Device is reset (display flashes)
<ul style="list-style-type: none"> • Number [5.] flashes when STO (Safe Torque Off) input is active. Display goes out when STO inactive. • The dot on the display flashes when the power stage is active. 	

Tabelle 6.43.1 Central state machine according to CiA 402



NOTE:

The system states indicated on the display may differ from the states in the table depending on the drive profile setting.

1 bis 16	State transition
----------	------------------

Bild 6.43.2 State machine according to CANopen communication

State machine schematic

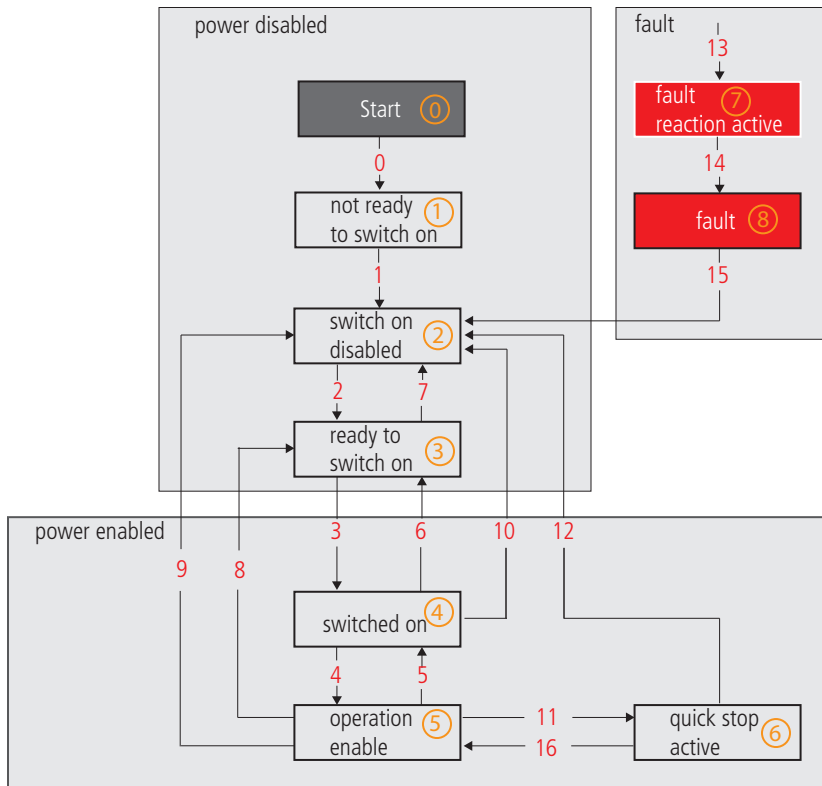

	State number
--	--------------

6.44 Touchprobe

6.44.1 Configuration of touchprobe functionality

Using the touchprobe inputs ISD05 and ISD06, touchprobe functions can be performed. HTL encoders can be evaluated or pulse counters implemented using the iPLC.

The touchprobe is activated via parameter **P 0240 "MPRO_TP_Ctrl"**. This enables triggering on a positive or negative edge, or on both edges, of the signal detected on the touchprobe inputs. After the measurement, the parameter jumps back to the value "NONE (0)" and the latch position is mapped in the corresponding subindex of parameter **P 0241 "MPRO_TP_Position"**. A continuous touchprobe mode is not possible at present, so the touchprobe has to be reactivated after the measurement.

Parameter **P 1402 "MPRO_TP_Channel"** can be used to select various positions as actual value sources of the latch position for the touchprobe functionality.

The following table provides an overview of the available settings. The inputs for ISD05 and ISD06 must be parameterized to Touchprobe (PROBE(15)). The counters are accessed via the iPLC or a bus system.

Device setup > Configuration of inputs/outputs > Digital inputs

P.no.:	Parameter name Settings	Function
P 0106	MPRO_INPUT_FS_ISD05	Function of digital input ISD 05
(15)	Probe(15)	Touchprobe

P.no.:	Parameter name Settings	Function
P 0107	MPRO_INPUT_FS_ISD06	Function of digital input ISD 06
(15)	Probe(15)	Touchprobe

Tabelle 6.44.1 Configuration of inputs

Device setup > Motion profile > Touchprobe

P.no.:	Parameter name Settings	Function
P1400	MPRO_TP_Config	Touchprobe configuration
(0)	TP_TP	ISD05, ISD06: Touchprobe
(1)	AB	ISD05, ISD06 as encoder tracks A/B, count direction via evaluation of pulse sequence
(2)	PD_UP	ISD05: Pulse counter (rising edge) ISD06: Count direction (TRUE := positive count direction)
(3)	PD_DOWN	ISD05: Pulse counter (rising edge) ISD06: Count direction (TRUE := negative count direction)
(4)	PC_PC	ISD05, ISD06: Pulse counter (both edges)
(5)	PC_TP	ISD05: Pulse counter (both edges) ISD06: Touchprobe
(6)	TP_PC	ISD05: Touchprobe ISD06: Pulse counter (both edges)

Tabelle 6.44.2 Touchprobe configuration **P 1400**

Device setup > Motion profile > Touchprobe (only for ISD05/ISD06)

P.no.:	Parameter name Settings	Function
P1402	MPRO_TP_Channel	Touchprobe configuration Probe channel
(0)	ACTPOS (0)	Actual position in user units
(1)	ACTPOSINC (1)	Actual position in increments
(2)	MASTERPOS (2)	Master position in increments
(3)	ENCPOS_CH1 (3)	Encoder position Channel 1
(4)	ENCPOS_CH1_INC (4)	Encoder position Channel 1 in increments
(5)	ENCPOS_CH2 (5)	Encoder position Channel 2
(6)	ENCPOS_CH2_INC (6)	Encoder position Channel 2 in increments
(7)	ENCPOS_CH3 (7)	Encoder position Channel 3
(8)	ENCPOS_CH3_INC (8)	Encoder position Channel 3 in increments
(9)	ENCPOS_CH4 (9)	Encoder position Channel 4
(10)	ENCPOS_CH4_INC (10)	Encoder position Channel 4 in increments
(11)	ACTPOS2 (11)	Actual position of redundant encoder in user units
(12)	SERCOS(12)	Referred to Sercos profile parameters S-x-0426, S-x-0427

Tabelle 6.44.3 Touchprobe configuration **P 1402**

Touchprobe configuration

P.no.:	Parameter name Settings	Function
P 0240	MPRO_TP_Ctrl	Touchprobe control word
(0)	NONE (0)	No function
(1)	POS (1)	Positive edge
(2)	NEG (2)	Negative edge
(3)	BOTH (3)	Both edges
P 0241	MPRO_TP_Position	Touchprobe latch position ISD05 and ISD06
(0)		Latch position ISD05, positive edge
(1)		Latch position ISD05, negative edge
(2)		Latch position ISD06, positive edge
(3)		Latch position ISD06, negative edge

6.45 Speed control in PG mode

6.45.1 Profile Generator mode (PG mode)

- Select reference source
- Motion profile adaptation: scaling, ramps and smoothing time.
- In reference processing by way of the profile generator the fine interpolator is always in use.



Bild 6.45.1 Profile mode speed control



NOTE:

For more information refer to the bus system user manuals or the description of the iPLC.

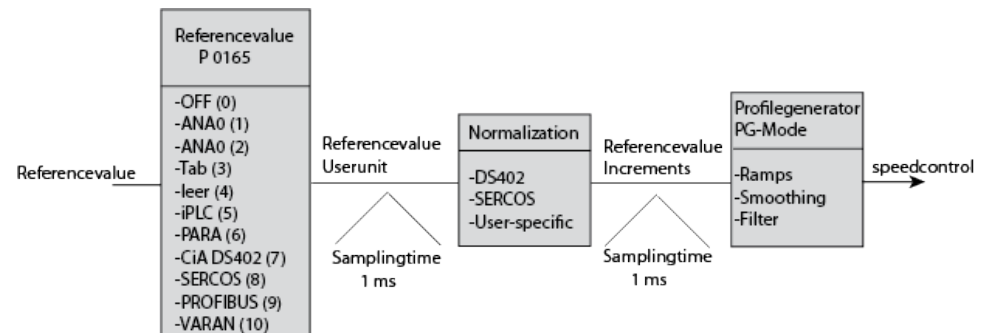
Vorgehensweise: Profile Generator with speed control:

- Control mode **P 0300 CON_CfgCon: = speed control**
- Under Profile select the profile generator (PG) **P 0301 CON_REF_Mode = PG(0)**
- Selection of reference source **P 0165 MPRO_REF_SEL**
- Scaling

- Select jerk conditions
- Set stop ramps, smoothing, filter, homing

The "Jerk time" setting box only appears on-screen when the profile type has been set to "JerkLim(3)".

Set control and reference

Control via: TERM(1) = via terminals

Reference via: TAB(3) = via table

Motor control start condition: OFF(0) = Switch off drive first in case of power or fault reset

Profile

Profile mode: PG(0) = reference acts on profile generator

Profile type: JerkLim(3) = Jerk limited ramp

Jerk time: 0 ms

Interpolation

Interpolation type: Splinell(3) = Cubic spline interpolation

Cycle time: 1 ms

Limit

Speed override: 100 %

Reversing lock: OFF(0) = No locking

Reference filter

Filter type: OFF(0) = Function disabled

Bild 6.45.2 Speed control in PG mode, smoothing

6.46 Speed control in IP mode

6.46.1 Preparing the speed reference

In IP (Interpolation) mode the appropriate reference source and correct scaling of units are selected for the speed reference before the reference is passed via the interpolator to the control. Linear interpolation is always applied in doing this.

Interpolation (IP) mode

- Reference values are interpolated in linear mode before being switched to the control loops.
- The profile generator is inactive.
- Ramps and smoothing are inactive.
- The reference values are switched directly to the closed-loop control. Note that the mechanism may be destroyed when this is done.

Speed control in IP mode:

- Control mode P 0300 CON_CfgCon = speed control or setting via Modes of Operation (CAN, EtherCAT)
- Selection of reference source P 0165 MPRO_REF_SEL
- Scaling
- Linear interpolation is always applied in speed control.
- Bus sampling rate: The bus sampling time is custom-set according to the application.



Bild 6.46.1 Speed control in IP mode (Motion Profile subject area)



Linear interpolation is always applied in speed-controlled mode. Pre-control is not active.

6.47 Position control in PG mode

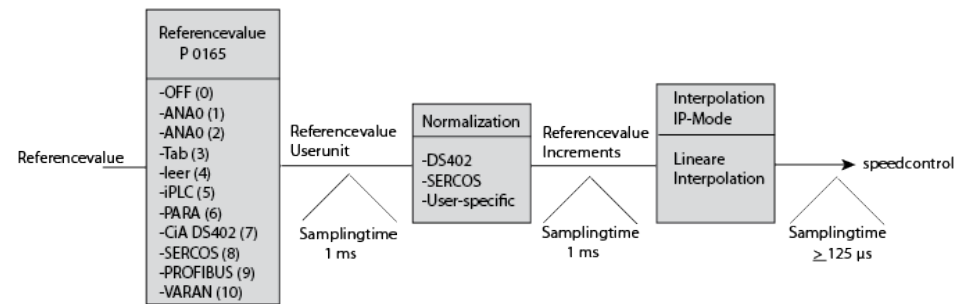
6.47.1 Profile Generator (PG) mode

Positioning commands are transmitted to the internal profile generator (subject area motion profile "Basic setting").

It is composed of the following items:

- Target position
- Maximum process speed
- Maximum acceleration
- Maximum deceleration
- With the values for jerk **P 0166 MPRO_REF_JTIME** and an override factor **P 0167 MPRO_REF_OVR** for the positioning speed, the profile generator generates a time-optimized trajectory for the position reference, taking into account all limitations.
- The position references are then processed with the selected interpolation method.
- The position references are used to generate pre-control values for speed and acceleration. These are scanned at the sampling time of the position controller (normally 125 µs) and switched to the control loops.

6.47.2 Motion profile / Basic settings

In this dialog box the basic settings for the motion profile are made according to the list boxes. If Profile Generator and IP mode are enabled, the reference value is influenced by both functions.



Bild 6.47.1 Profile mode position control

6.48 Position control in IP mode

6.48.1 Interpolation (IP) mode

- Position reference values are preset by a higher-level PLC with an appropriate sampling time.
- The sampling time must be balanced between the PLC and controller **P 0306 CON_IpRefts**.
- The position references are then transferred to the fine interpolator.
- Pre-control values for speed and acceleration are switched to the control loops.
- For more information on the cycle time refer to the field bus documentation.

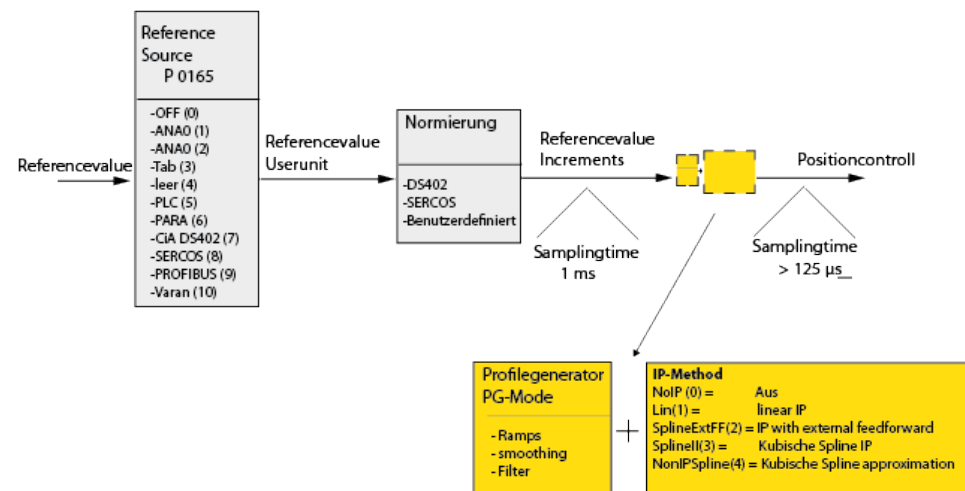

Bild 6.48.1 Position control in IP mode (Motion Profile subject area)



NOTE:

In linear interpolation the pre-control is ignored.

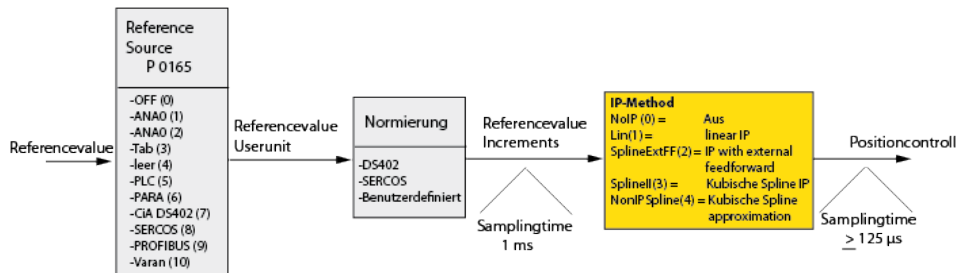
6.49 Jerk limitation and speed offset

6.49.1 Jerk limitation (Profile mode)

The transfer path from the motor to the mechanism may be elastic and so susceptible to oscillation. For that reason, it is advisable to also limit the maximum rate of change of the torque and thus the jerk. Due to the jerk limitation the acceleration and deceleration times rise by the smoothing **P 0166 MPRO_REF_JTIME**. The smoothing setting box appears on-screen as soon as the profile type **P 2243 "MPRO_402_MotionProf type"** is set to JerkLin(3).

6.49.2 Speed offset (limitation)

With speed override **P 0167 MPRO_REF_OVR** the maximum preset speed reference is scaled in percent.

Set control and reference

Control via: TERM(1) = via terminals

Reference via: TAB(3) = via table

Motor control start condition: OFF(0) = Switch off drive first in case of power or fault reset

Profile

Profile mode: PG(0) = reference acts on profile generator

Profile type: JerkLim(3) = Jerk limited ramp

Jerk time: 0 ms

Interpolation

Interpolation type: Splinell(3) = Cubic spline interpolation

Cycle time: 1 ms

Limit

Speed override: 100 %

Reversing lock: OFF(0) = No locking

Reference filter

Filter type: OFF(0) = Function disabled

Bild 6.49.1 Profile type, smoothing profile type without smoothing

The acceleration and braking ramp = 0, so the jerk is maximum (red curve).



Bild 6.49.2 Maximum jerk: Red = actual speed; grey = actual position

The acceleration and braking ramp with preset smoothing time (smoothing time = 2000 ms, red curve)

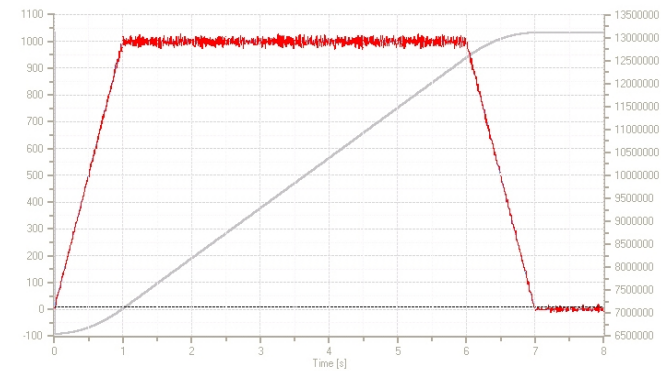

Bild 6.49.3 Ramps with smoothing: Red = actual speed; grey = actual position

Parameters

P.no.	Parameter name/ Settings	Function
P 0166	MPRO_REF_JTIME	Setting of smoothing time (jerk limitation)
P 0167	MPRO_REF_OVR	The reference is weighted in percent dependent on the maximum specified reference value
P2243	MPRO_402_MotionProfType	The smoothing time is only selectable when the parameter is set to Jerklim(3).

Tabelle 6.49.4 Parameters for setting jerk conditions

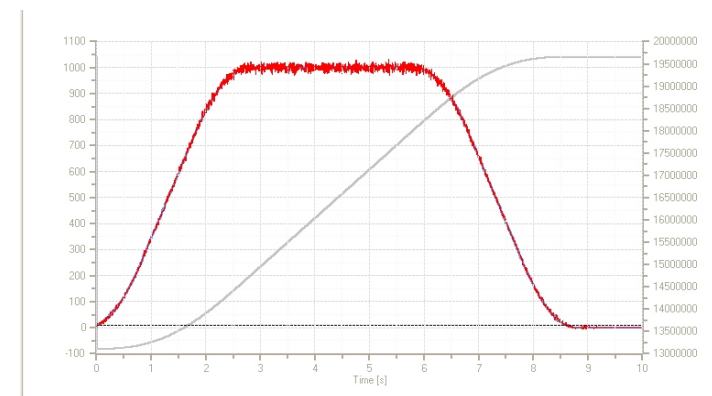
function is required. Even if f is not known, this is usually obtained naturally: The limitation, consistency or differentiation capacity can frequently be assumed.

Linear interpolation	Function
	Linear interpolation: Here two given datum points f_0 and f_1 are connected by a line.
	To $n+1$ differing datum point pairs there is exactly one n -th order interpolation polynomial, which matches at the specified interpolation points.

Bild 6.50.1 Linear interpolation

6.50 Interpolation types

6.50.1 General definition of interpolation

If only individual points of a function are known, but no analytical description of the function in order to evaluate it at random locations, a suitable interpolation method is applied to estimate the function at the points in-between. This is termed an interpolation problem. There are a number of solutions to the problem; the user must select the appropriate functions. Depending on the functions chosen, a different interpolant is obtained.

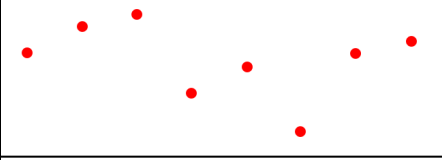
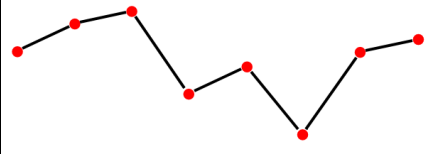
Interpolation is a kind of approximation: The function under analysis is precisely reproduced by the interpolation function at the interpolation points and at the remaining points is at least approximated. The quality of approximation depends on the method chosen. In order to estimate it, additional information above the

Cubic interpolation	Function
	As polynomials become more and more unstable as the order of magnitude increases – that is to say, fluctuate widely between the interpolation points – in practice polynomials of an order greater than 5 are rarely applied. Instead, large data sets are interpolated in chunks. In the case of linear interpolation, that would be a frequency polygon; in the case of 2nd or 3rd order polynomials the usual term used is spline interpolation. In the case of sectionally defined interpolants, the question of consistency and differentiation at the interpolation points is of major importance.
	

Bild 6.50.2 Cubic interpolation

The following interpolation types are available to select in the controller.

Parameter No.	Parameter Name	Function
P 0370	CON_IP	Interpolation type in IP mode
(0)	NoIp(0)	No interpolation: The values are transferred 1:1 to reference processing in 1 ms cycles.

Parameter No.	Parameter Name	Function
(1)	Lin (1)	Linear interpolation: In the linear interpolation method the acceleration between two points is generally zero. Pre-control of the acceleration values is thus not possible and speed jumps are always caused.
(2)	Spline_Ext_FF(2)	Interpolation with external pre-control: The expected result should exhibit a high degree of contour accuracy and little reference/actual value variation. For more information refer to the bus documentation.
(3)	Splinel(3)	Spline interpolation: In this method interpolation is effected between the interpolation points of the control by means of cubic splines. The trajectory is guided precisely by the control based on the specified points. This may cause a slight jerk at those points, noticeable in the form of "noise". Application: High contouring accuracy, slight "noise" is possible. "Noise" refers to mathematical anomalies which cannot be entirely eliminated by the computing methods applied.
(4)	NonIPSpline (4)	Cubic spline approximation method: In this method the interpolation points are approximated by means of B-splines. The trajectory normally does not run exactly through the points specified by the control. The deviation is normally negligibly small. In the interpolation points the transitions are continuous with regard to

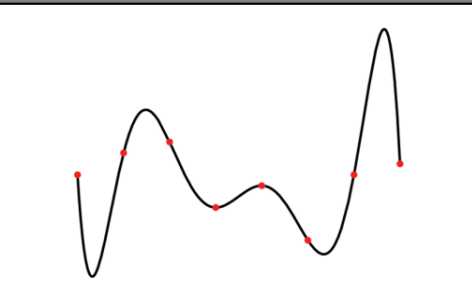
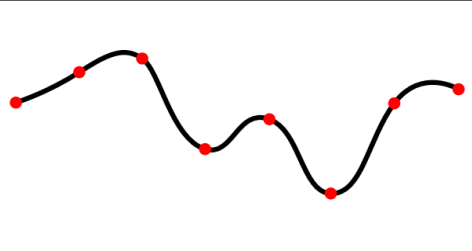
Parameter No.	Parameter Name	Function
		acceleration, which becomes apparent by minor "noise". In start and target position the interpolation points always match the trajectory. Application: Minimizing noise, smoother motion, restrictions on contouring
(5)	Cos(5)	Trigonometric interpolation: The interpolation formula corresponds to a Fourier trend of the unknown interpolants.

Tabelle 6.50.3 Interpolation types

7 Inputs/outputs

Information	
Navigation	Project tree < Device setup < Inputs/outputs
Pictograms	 Digitale Eingänge Digitale Ausgänge
Contents	<ul style="list-style-type: none">• Digital inputs Digital input function selectors.htm• Digital outputs Digital output function selectors.htm• Analog inputs Analog input function selector.htm• Analog outputs.htm• Selecting inputs and outputs.htm• Motor brake output.htm• Virtual inputs.htm

Tabelle 7.0.1 Inputs and Outputs subject area

7.1 Selecting inputs and outputs

The buttons provide a user-friendly means of navigating to the individual input and output types. They can be selected by way of the project tree. Choose "Oscilloscope signals from" to open the oscilloscope variable to record the status of the inputs and outputs. A highlighted variable can be assigned to a channel and recorded by right-clicking the mouse button. The function of the electronic oscilloscope is described in the DriveManager 5 Online Help.

Selection dialog box



Bild 7.1.1 Selecting inputs and outputs

7.2 Control location selector

The control location selector assigns the digital inputs their functionality. Setting a digital input ISDxx = "MAN(14)" allows a change of control location to the reference source selected in **P 0164 MPRO_REF_SEL_MAN**. This enables fast switching to manual control for setup or emergency running mode for example. When a digital input set to "MAN(14)" is activated, the control location **P 0159**

MPRO_REF_SEL switches to "TERM" (switch to "TERM" is not displayed in DM5). In parallel, the reference source is set to the reference selected via parameter **P 0164-MPRO_REF_SEL_MAN**. The start signal must be connected to a digital input (ISDxx = Start). The control mode **P 0300_CON_CfgCon** cannot be switched. The "MAN(14)" mode is displayed in the field bus control word.

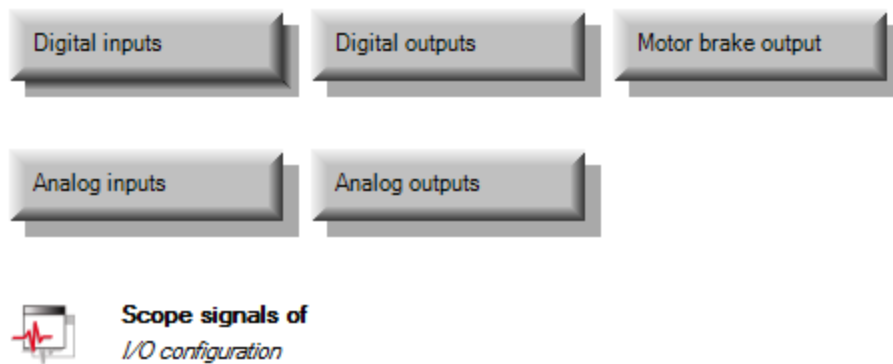
It is not possible to switch to "MAN" mode when the power stage is active or when the drive in the DriveManager 5 is operated via the manual mode window. A level-triggered START

P 0144 MPRO_DRVCOM_AUTO_START=LEVEL (1) is ignored in "MAN" mode. After activation of "MAN" mode, the START input must be reset. When "MAN" mode is ended the motor control also stops.

Parameters

P. no.	Parameter name/ Settings	Function
P 0164	MPRO_REF_Sel_MAN	Selection of motion profile
(0)	OFF	No profile selected
(1)	ANA0	Reference value of analog input ISA0
(2)	ANA1	Reference value of analog input ISA1
(3)	TAB	Reference from table
(4)	vacant	Not defined
(5)	PLC	Reference from PLC
(6)	PARA	Reference via parameter
(7)	DS402	Reference via CiA 402 IEC1131
(8)	SERCOS	Reference via SERCOS
(9)	PROFI	Reference via PROFIBUS

P. no.	Parameter name/ Settings	Function
(10)	VARAN	Reference via VARAN
(11)	TWIN	Reference via external option "TWINsync"

Tabelle 7.2.1 Control location selector for digital inputs

7.3 Function selector - digital inputs

7.3.1 Function selector of the digital inputs

All digital inputs of the controller are set by way of a function selector. The selector assigns each input a function.

The two inputs ISDSH and ENPO "Enable Power" are reserved for the hardware enable. For the touchprobe function the two "fast inputs" ISD05 and ISD06 are available. Settings (-5) to (-1) are reserve for use as an analog input.



Bild 7.3.1 Setting the digital inputs

Parameters

P. no.	Parameter name Setting	Function
P 0101- P 0107	MPRO_ INPUT_FS_ ISD00	Digital inputs
(0)	OFF	Input without function
(1)	START	Start of closed-loop control Motor is energized. The direction of rotation depends on the reference
(2)	INV	Invert reference
(3)	STOP	Quick-stop as per quick-stop reaction (Low active)
(4)	HALT	The ongoing axis movement is interrupted and resumed as per the "HALT" reaction following resetting.
(5)	LCW	Limit switch evaluation without overrun protection, positive direction. The reaction to limit switch overrun and to interchanged limit switches can be preset.
(6)	LCCW	Limit switch evaluation without overrun protection, negative direction. The reaction to limit switch overrun and to interchanged limit switches can be preset.

P. no.	Parameter name Setting	Function
(7)	INCH_P	Jog in positive direction
(8)	INCH_N	Jog in negative direction
(9)	HOMST	Start homing: according to the homing method parameterized in P 02261 MPRO_402_Homing Method
(10)	HOMSW	Reference cam to determine the zero for positioning
(11)	E-EXT	Error messages from external devices cause an error message with the reaction determined in parameter P 0030 Error-Reaction (11)
(12)	WARN	External collective warning
(13)	RSERR	Error messages are reset with a rising edge if the error is no longer present In some special case it is necessary to restart the device in order to reset an error. Note the settings in the "Error reactions" subject area.
(14)	MAN	In field bus operation switching of the reference source P 0165 CON_CfgCon and the control location P 0159 MPRO_CTRL to "Term" can be set via a digital switch.
(15)	PROBE	Touchprobe: The function can only be executed via the fast inputs ISD05 and ISD06 in conjunction with PLC or CANopen/EtherCAT.
(16)	PLC	Input can be evaluated by PLC program

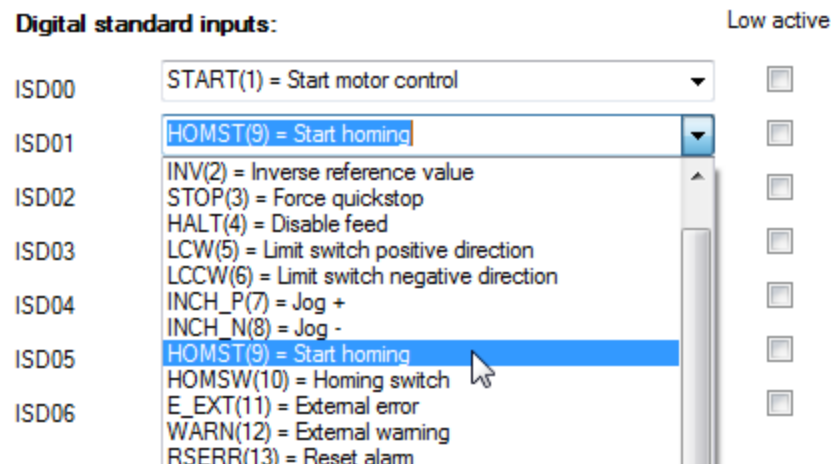
P. no.	Parameter name Setting	Function
(17)	PLC_IR	Interruption of the PLC program
(18)	MP_UP	Motor potentiometer: Increase reference value
(19)	MP_DOWN	Motor potentiometer: Decrease reference value
(20)	HALT_PC	Feed stop with subsequent position control
(21)	TBEN	Import and execution of selected table driving set
(22)	TBTEA	Teach-in for position references The current position is stored in the specified table index on a rising edge. The index can be defined via the inputs in binary format (setting 23-26) or set via parameter P 0207 . The teach-in function can also be activated by parameter P 0269- MPRO_TAB_Ctrl bit 0.
(23)	TAB0	Binary driving set selection (bit 0) , (significance 2 ⁰) for speed
(24)	TAB1	Binary driving set selection (bit 1), (significance 2 ¹) for speed or positioning
(25)	TAB2	Binary driving set selection (bit 2), (significance 2 ²) for speed or positioning
(26)	TAB3	Binary driving set selection (bit 3), (significance 2 ³) for speed or positioning
(27)	EGEAR	Engage electronic gearing
(28)	REFANAEN	Enable analog reference

P. no.	Parameter name Setting	Function
(29)	ENC	Use of ISD05 / ISD06 as encoder input (pulse count, pulse/direction).
(30)-(32)	Software-specific	
(34)-(35)	JOG_EXT_POS JOG_EXT_NEG	Jog mode in positive and negative direction.
(36)	FAST-DISC	Fast discharge of DC link (using a braking resistor)
(37)	LIM_OFF	Scaling of torque (P 0332 TmaxScale) and speed limitation (P 0337 SmaxScale) is disabled (ISDxx = "high"). If the function is not parameterized to an input (ISDxx = "low") the limits are always active.
(38)	LOCK_POS	Reversing lock, positive direction (access also via iPLC).
(39)	LOCK_NEG	Reversing lock, negative direction (access also via iPLC).
(40)	EMC_BRK	Emergency brake, direct engagement of holding brake
(41)	PWR_RELAIS	Manual switching of precharge relay (use only after consultation with LTI DRIVES GmbH).

Tabelle 7.3.2 Digital input settings

7.4 Hardware enable

The controllers support the "STO" (Safe Torque Off) safety function in accordance with the requirements of **EN 61800-5-2, EN ISO 13849-1 "PLe" and EN 61508 / EN 62061 "SIL 3"**. The safety function "STO" to **EN 61800-5-2** describes a safety measure in the form of an interlock or control function. "Category 3" signifies that the safety function will remain in place in the event of a single fault.

The connected control signals "ISDSH" and "ENPO" must always be tested by the operator or a higher-level PLC for plausibility relative to the feedback (RSH). The occurrence of an implausible status is a sign of a system error (installation or servocontroller). In this case the drive must be switched off and the error rectified.

The safety-related parts must operate in such a way that:

- a single fault in any of the said parts does not result in loss of the safety function;
- the single fault is detected on or before the next request to the safety function.

For the "STO" function the servocontrollers are equipped with additional logic circuits and a feedback contact (terminal RSH on X4). The logic cuts the power supply to the pulse amplifiers to activate the power stage. In combination with the controller enable "ENPO" the system uses two channels to prevent the motor creating a torque.

Testing the STO function

Function testing: The STO function (protection against unexpected starting) must essentially be checked to ensure it is operative:

- during initial commissioning;
- after any modification of the system wiring;
- after replacing one or more items of system equipment.
- Cancelling one of the two signals "ISDSH" or "ENPO" disables the control and the motor runs down unregulated.

7.4.1 Hardware enable or Autostart

The input "ENPO" is reserved for the hardware enable.

At the setting "OFF" the digital input signal "ENPO" is used merely for safe shutdown of the drive and as protection against switching on.

With the setting "START" in combination with parameter

P 0144 DRVCOM AUTO_START = "LEVEL" autostart mode is activated only in ServoOne.

With "STO active" activating the "ENPO" is sufficient to start control of the drive.

When the "ENPO" is cancelled the drive runs down uncontrolled.

If the switch-on delay is active, the power stage starts when the preset timer has elapsed.

The setting for the ENPO can be found in the "Digital inputs" dialog box.



Bild 7.4.1 Hardware enable – power stage with ENPO



NOTE:

The plausibility between input signals (ENPO, ISDSH) and feedback (RSH) must always be monitored.

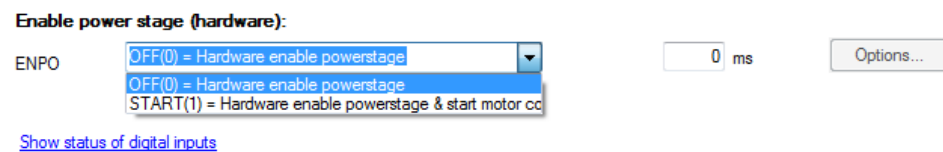
7.5 Power-up sequence

The power-up sequence must be maintained when the drive starts, regardless of the control mode. If the power-up sequence is followed, the drive starts with a rising edge of the digital input parameterized to "START" or when the corresponding "Start" bit is set via a bus system. The reference polarity determines the direction of rotation.



Bild 7.5.1 Time diagram of sequences

No.	Command	System state
1	Starting lockout	ISDSH Safe Standstill (STO)
2	Ready for start	ENPO EnablePower
3	On	Bit (0) = START(1)
4	Loop control active	Loop control active

Tabelle 7.5.2 System state of sequences

7.6 Digital output function selectors

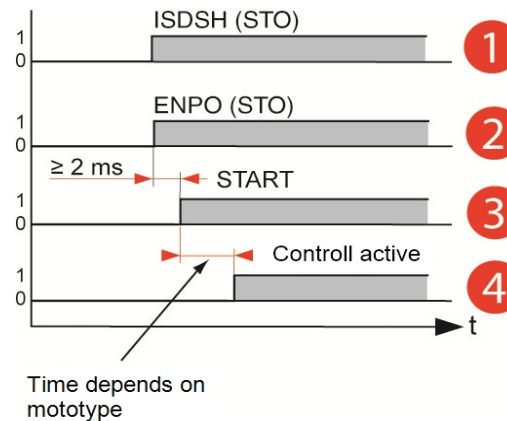
The standard digital outputs OSD00 to OSD02 are assigned the corresponding function via function selectors **P 0122 MPRO_OUTPUT_FS_OSD00** to **P 0124 MPRO_OUTPUT_FS_OSD02**. The relay output **P 0126 MPRO_OUTPUT_FS_RELOUT1** can also be assigned other functions via the function selectors as necessary.



NOTE:

The digital output **P 0127 MPRO_OUTPUT_FS_RELOUT2** is set by default to "SH_HSTO". Additional information on the STO function can be found in the "Safety" section of the Operation Manual.

Standard digital outputs

Digital standard outputs: Low active

OSD00	ACTIV(3) = Powerstage active	<input type="checkbox"/>	Options...
OSD01	HOMATD(7) = Homing attained	<input type="checkbox"/>	Options...
OSD02	HALT(13) = Drive in halt state	<input type="checkbox"/>	Options...
Relay output:	HOMATD(7) = Homing attained		
	E_FLW(8) = Tracking error		
	ROT_R(9) = Rotation right		
	ROT_L(10) = Rotation left		
	ROT_0(11) = Motor standstill	<input type="checkbox"/>	Options...
	STOP(12) = Drive in quickstop state		
	HALT(13) = Drive in halt state		
	LIMIT(14) = Reference limitation		
	T_GT_TX(15) = Torque greater than parameter 741		
	N_GT_NX(16) = Speed greater than parameter 740		
P_LIM_ACTIV(17) = Position reference limited			
N_LIM_ACTIV(18) = Speed reference limited			

[Show status of](#)

Bild 7.6.1 Dialog box for digital outputs

Parameters

P. no.	Parameter name Setting	Function
P 0122 - P 0127	MPRO_OUTPUT_FS_OSD0x	Function selection
(0)	OFF	Input off
(1)	ERR	Collective error message
(2)	BRAKE	Output activated according to holding brake function
(3)	ACTIVE	Power stage and control active
(4)	S_RDY	Output is activated when the device is initialized after power-on.
(5)	C_RDY	Output is activated when the device is "Ready to switch on" based on setting of the "ENPO" signal and no error message has occurred. Device ready - ReadyToSwitchOn flag in DriveCom status word set (in states 3, 4, 5, 6, 7)
(6)	REF	The preset reference has been reached (dependent on control mode)
(7)	HOMATD	Homing complete
(8)	E_FLW	Tracking error
(9)	ROT_R	Motor in standstill window when running right
(10)	ROT_L	Motor in standstill window when running left
(11)	ROT_0	Motor in standstill window, depending on actual value

P. no.	Parameter name Setting	Function
(12)	STOP	The drive is in the "Quickstop" state
(13)	HALT	The display system is in HALT state (activated via CiA402 profile, input or PROFIBUS IntermediateStop, SERCOS. Reaction according to HALT option code (P 2221 MPRO_402_HaltOC).
(14)	LIMIT	Output is set when a reference value reaches its limit.
(15)	T_GT_Nx	T is greater than Nx where Nx = value in P 0741 MON_Torque/forceThresh
(16)	N_GT_Nx	N is greater than the value in P 0740 MON_SpeedThresh
(17)	P_LIM_ACTIV	Position reference limited (e.g. with parameterized software limit switches)
(18)	N_LIM_ACTIV	Speed reference limitation active
(19)	T_LIM_ACTIV	Torque limitation active
(20)	not defined	Not defined
(21)	ENMO	Motor contactor output (wiring of motor via contactor)
(22)	iPLC	iPLC sets output
(23)	WARN	Collective warning message

P. no.	Parameter name Setting	Function
(24)	WUV	Warning: undervoltage in DC link
(25)	WOV	Warning: voltage overload in DC link
(26)	WIIT	Warning: I ² xt power stage protection reached
(27)	WOTM	Warning: motor temperature
(28)	WOTI	Warning: heat sink temperature of inverter
(29)	WOTD	Warning: internal temperature in inverter
(30)	WLIS	Warning: current threshold reached
(31)	WLS	Warning: speed threshold reached
(32)	WIT	Warning: I ² xt motor protection threshold
(33)	WLTD	Warning: torque limit value reached
(34)	TBACT	Table positioning in "AUTO" and activated state
(35)	TAB0	Significance 2 ⁰
(36)	TAB1	Significance 2 ¹
(37)	TAB2	Significance 2 ²
(38)	TAB3	Significance 2 ³
(39)	COM_1MS	Set output via field bus in 1 ms cycle
(40)	COM_NC	Set output via field bus in NC cycle
(41)-(54)	not defined	Not used
(55)	SH_S Safe torque off	STO function active

P. no.	Parameter name Setting	Function
	(STO)	
(56)	BC_Fail	Brake chopper error; triggered with negative edge
(57)	ESYNC	Synchronized movement engaged
(58)	IDLENESS	Logic link of motor standstill and "Not Ready to Switch on" state
(59)	P_RDY	Power enabled to the drive (DC link voltage + Safe Standstill + Enpo)
(60) - (79)	not defined	Not used
(80)	DIS_ACT	Fast-discharge active
(81)	WBRC	Warning, brake chopper overheated
(82)	FR_ACT	"Fault Reaction active" state
(83)	F_ACT	Error message

Tabelle 7.6.2 Digital output parameters

7.7 Reference reached REF(6)

7.7.1 Threshold definition

If a digital output is set to REF(6) for torque and speed control as well as positioning, a range can be defined in which the actual value may deviate from the reference without the "Reference reached REF(6)" message becoming inactive. Reference value fluctuations caused by reference input are thus taken into

account.



Bild 7.7.1 Threshold definition

7.8 Reference limitation LIMIT (14)

The output function LIMIT(14) detects when a reference value reaches its limit. In this case the output is set. The limit values for maximum torque and maximum speed depend on the preset control system.

7.8.1 Torque control

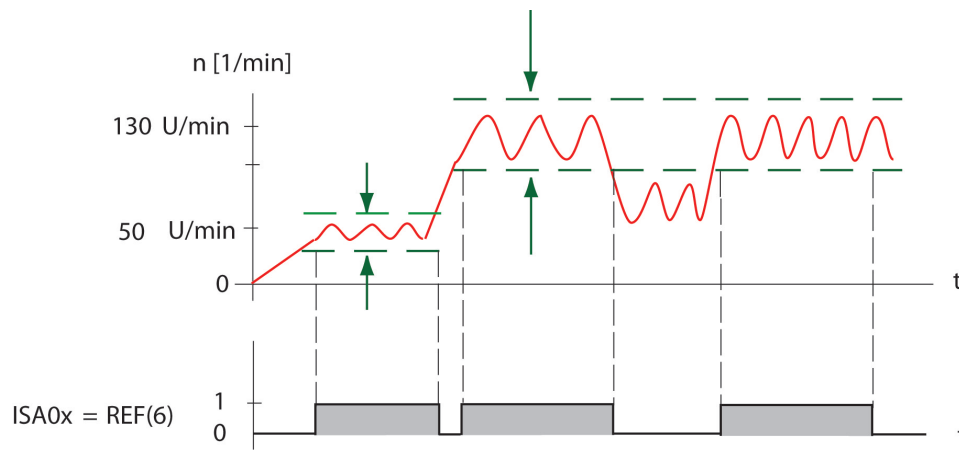
Limit value monitoring becomes active when the torque reference exceeds the maximum torque.

7.8.2 Speed control

Limit value monitoring becomes active when the speed reference exceeds the maximum speed.

7.8.3 Positioning

Limit value monitoring becomes active when the speed reference exceeds the maximum speed or the torque reference exceeds the maximum torque.

7.8.4 Infinite positioning/speed mode:

Monitoring is activated in infinite positioning (speed mode) when the speed reference has been reached. If an ongoing positioning operation is interrupted with "HALT", the "Reference reached" message is not sent in this phase. The message only appears after the actual target position has been reached.

7.9 Switching with motor contactor

The motor cable may only be switched with the power cut, otherwise problems such as burnt-out contactor contacts, overvoltage or overcurrent shut-off may occur. To ensure currentless switching, the contacts of the motor contactor must be closed **before enabling the power stage**. In the opposite case the contacts must remain closed until the power stage has been switched off. This can be achieved by implementing the corresponding safety periods for switching of the motor contactor into the control sequence of the machine or by using the special "ENMO" software function of the drive controller.

A power contactor in the motor supply line can be directly controlled by the drive controller via parameter **P 0125 MPRO_OUTPUT_FS_MOTOR_BRAKE = BRAKE**. The timer **P 0148 MPRO_DRVCOM_ENMO_Ti** defines the on-and-off delay of the power contactor. Based on the time delay, the reference value is applied after the power

contactor is active. If the power stage is switched off, the power contactor isolates the motor from the controller.



NOTE:

The **P 0148 MPRO_DRVCOM_ENMO_Ti** timer time should allow additional times for typical contactor bounce. They may be several hundred ms, depending on contactor.

Analog standard inputs:



Bild 7.10.1 Analog input function selector (-5) to (-1)

7.10 Analog input function selector

The reference processing method is selected by way of the function selector. The default setting is the function RERV(-2), with which the reference input +/-10 V is evaluated referred to user units.

The parameters are initialized only after the control has been re-enabled or by a device restart.

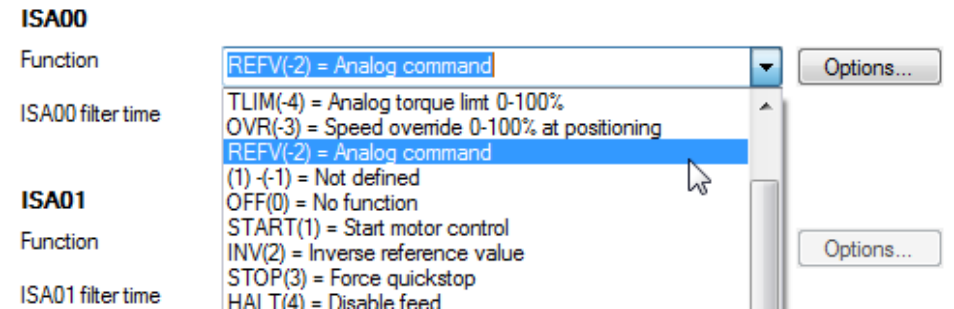
The selection TLIM(-4) to REFV(-2) is reserved for the analog input function. The other settings can be used for the function as a digital input.

Settings for the analog input

P. no.	Parameter name Setting	Function
P 0109/ P 0110	MPRO_INPUT_ FS_ ISA00/ISA01	Reference selector for the analog inputs
(-5)	Not defined	Not defined
(-4)	TLIM(-4)	Torque scaling: 0 to 10 V corresponds to 0-100% of the maximum set torque. The backlash is not effective for these functions.
(-3)	OVR(-3)	Scaling of the parameterized travel speed in positioning (0 to 10 V corresponds to 0 – 100%). The

P. no.	Parameter name Setting	Function
		override is recorded directly after the analog filter. The backlash is not effective for these functions!
(-2)	REFV(-2)	Reference input +/-10 V referred to user units.

Tabelle 7.10.2 Reference selector

7.11 Interpolated mode (IP) and Profile Generator mode (PG)

Parameter **P 0301 CON_REF_Mode** determines whether the reference values are processed via the profile generator (setting PG(0)) or directly (setting IP(1)). If direct input via IP mode is selected, only the input filters are active. The analog values are in this case scanned and filtered in the torque control cycle and then directly transferred as references for the speed or torque control.

NOTE:



The analog inputs are scanned in a 1 ms cycle. By switching parameter **P 0301 CON_REF_Mode** from PG(0) to IP(1) Mode, an analog input can be used as a "fast input" (e.g. Touchprobe). The sampling time set in parameter **P 0306 CON_IpRefTS** for the interpolation takes effect.

7.12 Wire break monitoring

7.12.1 Wire break detection threshold setting

The threshold for wire break monitoring is defined by **P 0399 CON_ANAWireBrk_Th**. If the voltage falls below this limit an error message is generated. The error reaction can be programmed by parameter **P 0030 EncoderReactions Index 52**.

Project tree **Device setup Others < I/O configuration < P 0399**.

P. no.	Parameter / Setting	Function
P 0399	CON_ANA_WireBrk	Wire break detection limit
(0)	ISA00	Wire break detection limit for analog input ISA00
(1)	ISA01	Wire break detection limit for analog input ISA01

Tabelle 7.12.1 Wire break monitoring

7.13 Analog input scaling

7.13.1 Analog input scaling function

With the scaling of the analog input the analog value can be converted with a factor, offset and backlash to the process variable. The illustration shows how the scaling function works. Entering the desired voltage range produces the parameter value for the gain

P 0428 ANA0/1 and the offset **P 0429 ANA0/1 Gain**.

- Change to input voltage range of analog torque scaling
- Change to input voltage range of speed override function
- Change to switching threshold of a digital input function

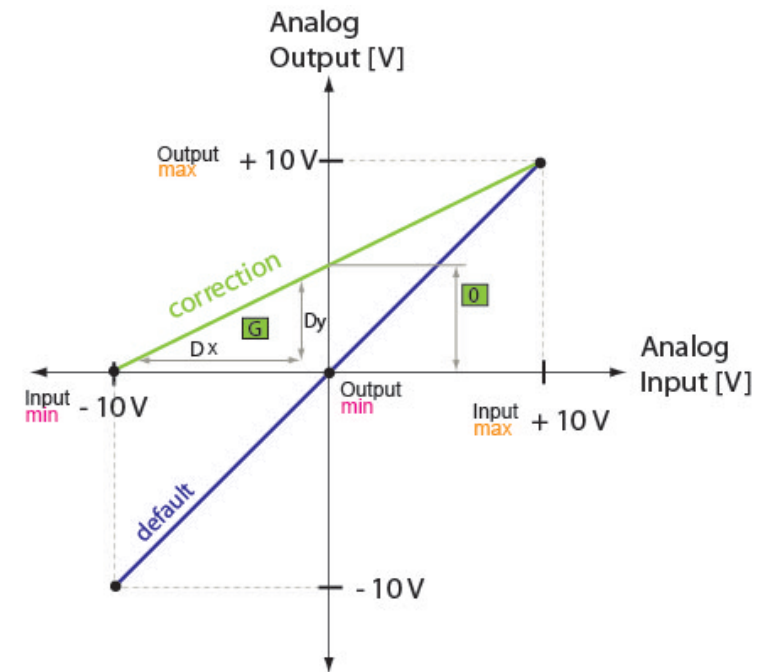

Gain P 0428 (0, 1)	$G = \frac{(OUT_{max}[V]) - (OUT_{min}[V])}{(IN_{max}[V]) - (IN_{min}[V])}$
Offset P 0429 (0, 1)	$0 = [(OUT_{min}[V]) - (IN_{min}[V])] \times G$

Output	$OUT_{min}[V] = [0 + IN_{min}] \times G$
	$OUT_{max}[V] = [0 + IN_{max}] \times G$

Bild 7.13.1 Scaling of an analog channel

Example: Analog torque weighting

Default setting (standard controller function):
 An input voltage range of the torque scaling from 0 V to +10 V corresponds to 0% - 100%.
 -10 V to 0 V corresponds to 0%.

Setting of input and offset gain:

- Input voltage range (+10 V/-10 V)
 -10 V corresponds to 0%
 +10 V corresponds to 100% of the torque scaling
- Settings:
 -10 V Input voltage: Torque scaling = 0%
 $In_{min} = -10$ corresponds to 0 V Output voltage: $Out_{min} = 0$ V
- +10 V input voltage: Torque scaling = 100%
 $In_{max} = +10$ V corresponds to +10 V output voltage, $Out_{max} = 10$ V
- Result:
 Gain: $G = 0.5$
 Offset: $O = 5$ V

7.14 Analog outputs

There are two analog outputs: OEA00, OEA01. They can only be used via the **CANopen+2AO option module** and are used to feed analog signal values out of the controller for further processing. To set OEA00 and OEA01 the actual value source must be defined. The values can be filtered, scaled and assigned an offset.

For more information refer to the CANopen+2AO specification with the Id-Nr. 1108.00B.0-00.

Analog outputs (option module CANopen+2AO)

Scaling

+/- 10 V correspond to	<input type="text" value="P 0173 (2)"/>	<input type="text" value="3000"/>	degree/s/10
Offset (O)	<input type="text" value="P 0174 (2)"/>	<input type="text" value="0"/>	degree/s
Backlash (B)	<input type="text" value="P 0175 (2)"/>	<input type="text" value="0"/>	degree/s

Motion profile

Acceleration ramp	<input type="text" value="P 0177 (0)"/>	<input type="text" value="1000"/>	degree/s/s
Deceleration ramp	<input type="text" value="P 0177 (1)"/>	<input type="text" value="1000"/>	degree/s/s



Bild 7.14.1 Analog outputs OEA00, OEA01

Parameters

P. no.	Parameter name Setting	Function
P 0129/ P 0130	MPRO_ Output_FS_ OSA0/1	Function selection
(0)	OFF (0)	No function
(1)	NACT(1)	Actual speed value
(2)	TACT(2)	Actual torque value

P. no.	Parameter name Setting	Function
(3)	IRMS(3)	Actual current value
(4)	PARA (4)	Value in parameter P 0134 MPRO_OUTPUT_OSAx_Values is delivered directly on the analog output.
(5)	ACTPOS	Actual position
(6)	VDC	DC-link voltage
P 0131	MPRO_ Output_ OSAx_Offset	Offset
(0)	Offset	Voltage offset [V]:
(1)	Offset	Offset setting: Changing P 0131 MPRO_OUTPUT_OSA0x_Offset shifts the operating point of the analog outputs out of the 0 point.
P 0132	MPRO_ Output_ OSA0_Scale	Scale
(0)	Scale	Scaling of the analog output:
(1)	Scale	setting of the Scale function: The scaling function can be used to scale the analog output.
P 0133	MPRO_ Output_ OSA0_Filter	Filter
(0)	Filter	Filter time of analog output:
(1)	Filter	Filter function setting: Noise and component spread can be compensated.

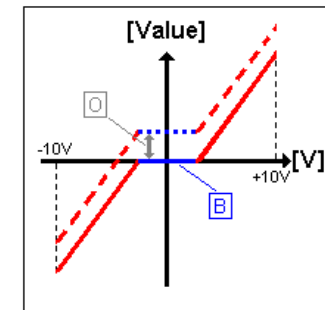
Tabelle 7.14.2 Analog outputs

7.15 Motor brake output

7.15.1 Using a motor brake

An optional holding brake built-in to motor provides protection against unwanted motion when the power is cut and in case of error. If the brake is mounted on the axis mechanism and not directly on the shaft, note that undesirably severe torsional forces may occur on sudden engagement of the brake.

The output **P 0125 MPRO_OUTPUT_FS_Motor_Brake** should be used in conjunction with a motor brake. On this output the current is explicitly monitored and wire break monitoring can be enabled. The brake function can also be used in the other digital outputs, though without current and wire break monitoring. If the output is set to BRAKE(2), the brake can be configured by way of the option field. The brake response can be adapted to the requirements of the application as shown in the following illustration and using the parameters listed. This function can be used in both speed as well as position controlled operation. The wire break monitor **P 0748 MON_MotorbrkGuard** can be enabled and disabled. Parameter **P 0148 ENMO** is used to set the time for enabling a motor switch ("Timeout Ready to switch on").



Bild 7.15.1 Brake response

Number	P. no.	Function
1 + 6	P 0148	ENMO: Enable and disable motor switch
2	P 0215	torque rise time: Torque rise time
3	P 0213	break lift time Brake lift time
4	P 0214	break close time

Number	P. no.	Function
		Brake close time
5	P 0216	torque fade time Torque fade time
7	P 0218	constant initial torque Constant initial torque value (see parameter description table) not visible in graphic
8	P 0217	factor of application of last torque Factor of last pre-tension (see parameter description table) not visible in graphic

Tabelle 7.15.2 Brake settings

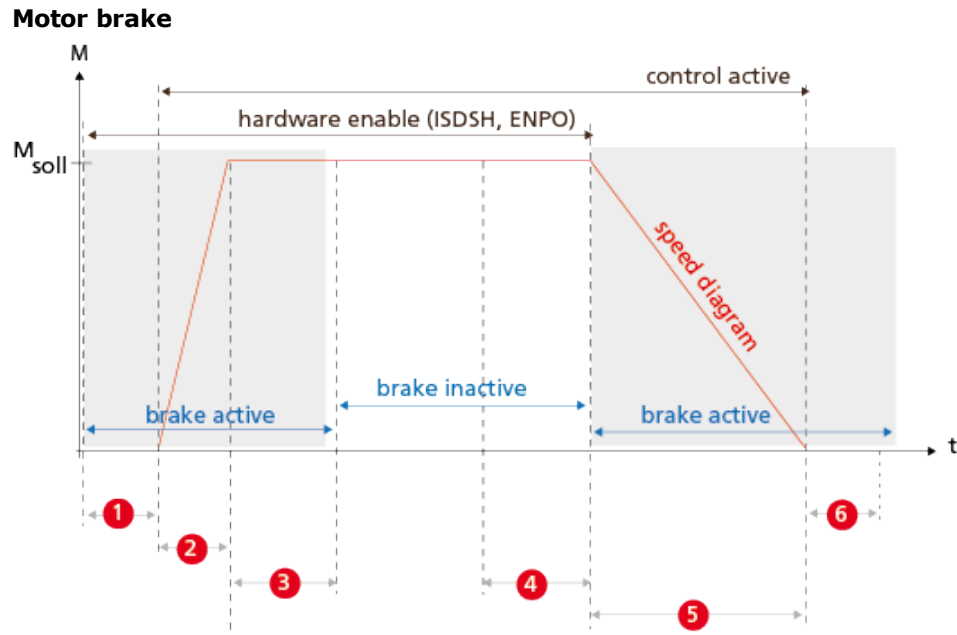
Parameters

P. no.	Parameter name Setting	Function
P 0125	MPRO_ OUTPUT_FS_ MOTOR_ BREAK	Output for use of a motor brake. If no brake is used, the output can be used for a vast variety of other functions.
(2)	BRAKE	Setting for use of a brake
P 0147	MPRO_ DRVCOM_ EPCHK	Switch-on condition (hardware switch)
(0)	No Check	Hardware enable "ENPO" is switched via the "ENMO" function.

P. no.	Parameter name Setting	Function
(1)	Check	ENPO must be switched via a digital input.
P 0148	MPRO_ DRVCOM_ ENMO [0-65535 ms]	The timer "ENMO" (Enable motor contactor) generates an On/Off-delay of the motor contactor and thus of the power stage. The effect is active when setting and resetting the "START" command and in case of error. The parameter is in the "Motion profile" subject area.
P 0213	MPRO_BRK_ LiftTime [0-10000 ms]	"Brake release time" is the mechanically dictated opening time of the brake. An applied reference will only be activated when this timer has elapsed.
P 0214	MPRO_ CloseTime [0-10000 ms]	After cancellation of the "START" command the "Brake close time" starts. When it ends the "Brake closed" signal is sent. In the event of an error, the brake engages immediately without any closure time.
P 0215	MPRO_ RiseTime [0-10000 ms]	The "Torque rise time" is the rise of the ramp to build up the reference braking torque "Mref".
P 0216	MPRO_BRK_ FadeTime [0-10000 ms]	The "torque fade time" is the descending ramp to reduce the reference torque "Mref" to 0.
P 0217	MPRO_BRK_ LastTorqFact [0-100%]	If the load changes, it is advisable to apply factor 1-100% to the last actual torque stored (0% = function off).
P 0218	MPRO_BRK_ StartTorq	If the moving load always remains constant, "Mref" is set by way of parameter

P. no.	Parameter name Setting	Function
		P 0218 MPRO_BRK_StartTorq "Starttorque". Mref =lasttorque * lasttorque-factor+ starttorque When setting the Lasttorque factor = 0 according to the formula, only the Starttorque setting is used. If Starttorque is set to 0, the Lasttorque is used. On first operation there is no Lasttorque though. In this case StartTorque is set to 0 and the LastTorque factor unequal to 0 and then the control is started.
P 0219	MPRO_BRK_ LastTorq	Display parameter of last recorded torque Scaling via P 0217 MPRO_BRK_LastTorq
P 0220	MPRO_BRK Lock	Only for testing. Manual setting of this parameter causes the brake to engage.

Tabelle 7.15.3 Brake settings



NOTE:

Please check the settings of the stop ramps if use of a holding brake is specified.

7.16 Virtual inputs

Virtual inputs are digital software inputs actuated via iPLC or field bus. The virtual inputs **P 0111[0] MPRO_INPUT_FS_ISV00** and **P 0112[0] MPRO_INPUT_FS_ISV01** can use all digital functions which are also available to the real digital inputs.

Activating virtual inputs

P. no.	Parameter name	Setting
P 0120	MPRO_INPUT_INV	Setting = 1
P 0111	MPRO_INPUT_FS_ISV00	Virtual input ISV00
(0) - (40)	OFF(0) to BREAK_ON(40)	All digital functions are programmable.
P 0112(0)	MPRO_INPUT_FS_ISV01	Virtual input ISV01
(0) - (40)	OFF(0) to BREAK_ON(40)	All digital functions are programmable.

Tabelle 7.16.1 Setting for the "Virtual inputs" function ISV00 and ISV01

8 Limits and thresholds

Information	
Navigation	Project tree < Device setup < Limits and thresholds
Pictograms	 Begrenzungen
Contents	<ul style="list-style-type: none">• Limit value settings.htm• Limitation by software limit switch.htm• Voltage threshold_mains powerfail reaction.htm

Tabelle 8.0.1 Limits and thresholds subject area

8.1 Limit value settings

8.1.1 Torque/speed/position limitation

To protect the device, the motor and the complete plant it is necessary to limit the variables torque, speed and position. These limits act independently of other limitations within the motion profile.

The limits are specified as percentages of the rated quantities (current, torque, speed,...), so that following calculation logical default settings are available. The default settings refer to 100% of the rated values and the parameters must thus be adapted to application and motor. The motor quantity limits can be read out in parameter **P 0338 CON_SCON_ActMax**.

Limitations in closed-loop controlled mode:

- Torque/force limitation:
- Speed limitation
- Position limitation



Bild 8.1.1 Schematic of torque/speed/position limitation

8.1.2 Torque limitation

The torque is limited to a maximum by parameter **P 0329 CON_SCON_TMax**. In the default setting the torque limit corresponds to the rated torque of the motor. The possible setting range is 0 - 1000%. The parameter cannot be changed during operation. Any change only takes effect after restarting the control. Parameter **P 0332 CON_SCON_TMaxScale** enables the torque limit set in **P 0329** to be scaled online – that is, during operation. It is additionally possible via **P 0330 CON_SCON_TMaxNeg** and **P 0331 CON_SCON_TMaxPos** to change the torque limit for different directions of rotation during operation.

P. no.	Parameter name/Setting	Function
P 0225	MPRO_REF_HOMING_TMaxScale	In the case of homing methods -8, -9, -10, -11 tracking error monitoring is disabled during execution. This avoids an error message being generated on contact with the block. The maximum permissible torque can be reduced specifically during homing. To do so, parameter P 0225 MPRO_REF_HOMING_TMaxScale is set in the range 0-100%. Note that this parameter replaces parameter P 0332 CON_SCON_TMaxScale during the homing run.
P 0329	CON_SCON_TMax	Scaling of the maximum torque, referred to the rated torque P 0460 MOT_TNom The parameter cannot be changed online.
P 0330	CON_SCON_TMaxNeg	Torque limitation in negative direction The parameter can be changed online.
P 0331	CON_SCON_TMaxPos	Torque limitation in positive direction. The parameter can be changed online.
P 0332	CON_SCON_TMaxScale	Percentage weighting of torque, default 100% The parameter can be changed online. When running homing methods -8, -9, -10, -11 parameter P 0332 has no effect. In this case the torque scaling should be executed via P 0225 .
P 0460	MOT_TNom	Motor rated torque
P 0741	MON_	Setting of limit for torque threshold (e.g. digital

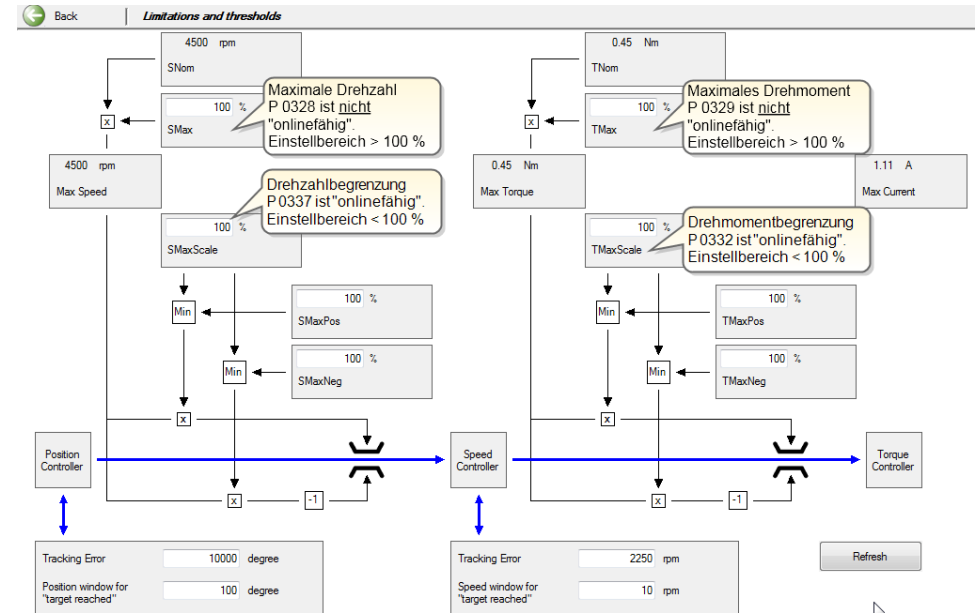
P. no.	Parameter name/Setting	Function
	TorqueThresh	output).

Tabella 8.1.1 Parameters for torque limitation



NOTE:

To protect against overspeed if a requested torque is not reached, **P 0337 CON_SCON_SMaxScale** is used to limit the speed controller to a percentage of the rated speed.

8.1.3 Speed limitation

The speed is limited to a maximum by parameter **P 0328 CON_SCON_SMax**. In the default setting the speed limit corresponds to the rated speed of the motor. The possible setting range is 0 - 1000%. The parameter cannot be changed during operation. Any change only takes effect after restarting the control. Parameter **P 0337 CON_SCON_SMaxScale** enables the speed limit set in **P 0328** to be scaled online – that is, during operation. It is additionally possible via **P 0333 CON_SCON_SMaxNeg** and **P 0334 CON_SCON_SMaxPos** to change the speed limit for different directions of rotation during operation. The "Speed reference reached window" is preset with **P 0745(0) MON_RefWindow Target Reached**. With **P 0745(1) MON_RefWindow Standstill** the standstill window for ROT_0 (speed 0), ROT_R (direction of rotation right) and ROT_L (direction of rotation left) is preset. The settings take effect online.

Parameters

P. no.	Parameter name/ Setting	Function
P 0167	MPRO_REF_OVR	Setting of override factor (speed limitation)
P 0328	CON_SCON_Max	Absolute entry of maximum speed, referred to the rated speed P 0458 MOT_SNom . (not changeable online)
P 0333	CON_SCON_S_MaxNeg	Speed limitation in negative direction (changeable online).
P 0334	CON_SCON_S_MaxPos	Speed limitation in positive direction (changeable online).
P 0335	CON_SCON_DirLock	Reversing lock, left and right (not changeable online)
P 0337	CON_SCON_S_MaxScale	Explicit standstill window for friction torque compensation Speed scaling, default 100% (changeable online)
P 0338	CON_SCON_ActMax	Limitations of motor quantities; current limit settings at a glance (current, speed, torque)
(0)	ActMax_Speed	Maximum speed Speed limitation
(1)	ActMax_Current	Maximum current Current limitation
(2)	ActMax_Torque	Maximum torque Torque limitation
(3)	ActMax_	Maximum speed

P. no.	Parameter name/ Setting	Function
	UsrSpeed	Speed limitation in user units
(4) - (6)	Reserve	Reserve
P 0740	MON_SpeedThresh	Setting of threshold for maximum speed
P 0744	MON_SDiffMax	Setting of threshold for maximum speed tracking error.
P 0745	MON_RefWindow	Standstill window for speed
(0)	Target reached	"Speed reference reached" window (changeable online)
(1)	Standstill	With the "Standstill" setting the standstill window for ROT_0 (speed 0), ROT_R (direction of rotation right) and ROT_L (direction of rotation left) is preset. (changeable online)

Tabelle 8.1.1 Parameters for speed limitation

8.1.4 Position limitation

With these two parameters the maximum permitted tracking error is defined. So as to specify a stable target position, the standstill window should be set correspondingly large.

Parameters

P. no.	Parameter name/ Setting	Function
P 0743	MON_UsrPosDiffMax	Limit value for the maximum permissible tracking error in user units.
P 0746	MON_UsrPosWindow	Standstill window for position reached

Tabelle 8.1.1 Parameters for position limitation

8.2 Limitation by software limit switches

8.2.1 Software limit switch

The software limit switches are only applicable in positioning mode, and are only activated once homing has been completed successfully. They are parameterized in the "Digital inputs" subject area.

Positioning mode	Function
Absolute	Before enabling an absolute motion task, a check is made whether the target is in the valid range – that is, within the software limit switches. If the target is outside, no driving job is signalled and the programmed error reaction as per P 0030 P 0030 Error Reactions is executed.
Infinite (only)	The drive travels until a software limit switch is detected. Then the programmed error reaction is executed.

Positioning mode	Function
speed-controlled)	

Tabelle 8.2.1 Positioning mode

Parameters

P. no.	Parameter name/ Settings	Function
P2235	MPRO_402_SoftwarePosLimit	Software limit switches
(0)	Software Position Limit	Negative limit switch
(1)	Software Position Limit	Positive limit switch

Tabelle 8.2.2 Software limit switch parameters



Note:

The reaction on reaching a software limit switch depends on the programmed error reaction.

[Error reactions.htm](#)

8.3 Power failure reaction

8.3.1 Response to power failure

If the value of the DC link voltage drops below the value set in parameter **P 0747 MON_PF_OnLimit**, the error ERR-34 "Power failure detected" is reported and the

parameterised error reaction is triggered. By parameterizing a quick stop as the error reaction with a sufficiently steep deceleration ramp, the DC link voltage can be maintained above the undervoltage threshold (power failure bridging). This reaction lasts until the drive has been braked to a low speed.

Power failure reaction

P. no.	Parameter name/Setting	Function
P 0747	MON_PF_ONLimit	Voltage threshold for power failure reaction
P 0749	MON_Def_OverVoltage	DC link overvoltage
The default setting is 0 V (function "Off").		

Tabelle 8.3.1 Voltage threshold for power failure

9 Alarm and warning

Information	
Navigation	Project tree < Device setup < Alarm and warnings
Pictograms	 Warnungen  Gerätestatus
Alarm and warning	<ul style="list-style-type: none">• Error list.htm• Error display.htm• Error reactions.htm• Warning thresholds.htm• Warning status.htm

Tabelle 9.0.1 Alarm and warning subject area

9.1 Error display

9.1.1 Meaning of error display

There are a number of way of displaying an error message. An error message is indicated on the display of the drive controller (display D1/D2) or via the DriveManager 5. It provides a user-friendly readout in the "Device status" window.

Display

The controller display indicates the rear of the device states and possible error messages. Two 7-segment displays are available for the purpose. To display an error number and an error, "ER" for Error flashes, then the error number, and then the number of the error location.

Example: ER-16-01 (1) Max. speed difference detected





Display readout	Function
	Attention – error message
	Errors marked with a dot on the display (D1/D2) can only be reset when the cause of the fault has been eliminated.
	Maximum overspeed detected
	Speed tracking error above threshold value

Tabelle 9.1.1 Error display

Display window in DriveManager 5



Bild 9.1.2 Displayed error

9.2 Error list

Parameters

Error No.	Error location	Error handling	Emergency code CiA402
0	(0) no error	No error	0xFF00
(1)	(1) RunTimeError	Runtime error	0x6010
(2)	(2) RunTimeError_DynamicModules	Internal error in device initialization	0x6010
(3)	(3) RunTimeError_Flashmemory	Error in flash initialization	0x6010
(4)	(4) RunTimeError_PLC	PLC runtime error	0x6010
2	ParaList		
(1)	(1) ParameterInit	Error in parameter initialization	0x6320
(2)	(2) ParameterVirginInit	Basic parameter initialization (factory setting)	0x6320
(3)	(3) ParameterSave	Parameter data backup	0x5530
(4)	(4) ParameterAdd	Registration of a parameter	0x6320
(5)	(5) ParameterCheck	Check of current parameter list values	0x5530
(6)	(6) ParameterListAdmin	Management of parameter list	0x6320
(7)	(7) ParaList_PST	Non-resettable errors from power stage: EEPROM data error	0x5400
(9)	(8) ParaList_PST_VL	Error in power stage initialization; selected device	0x6320

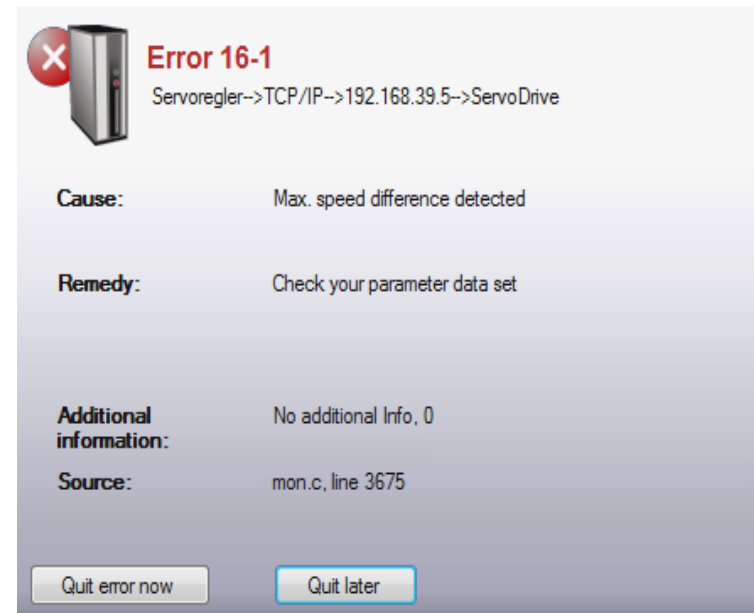
Error No.	Error location	Error handling	Emergency code CiA402
		voltage not supported	
3	OFF		
(1)	(1) Off_MON_Device	Undervoltage	0x3120
4	Overvoltage		
(1)	(1) OverVoltage_MON_Device	Overvoltage	0x3110
5	Overcurrent		
(1)	(1) OverCurrent_HardwareTrap	Overcurrent shut-off by hardware	0x2250
(2)	(2) OverCurrent_Soft	Overcurrent shut-off (fast) by software	0x2350
(3)	(3) OverCurrent_ADC	Measuring range of AD converter exceeded	0x2350
(4)	(4) OverCurrent_WireTest	Short-circuit test on initialization	0x2350
(5)	(5) OverCurrent_DC	(Fast) Overcurrent shut-off "below 5 Hz"	0x2350
(6)	(6) OverCurrent_Zero	Total current monitoring	0x2350
(7)	(7) OverCurrent_I2TS	Fast I ² xt at high overload	0x2350
6	Overheating		
(1)	(1) OvertempMotor_	Calculated motor temperature	0x4310

Error No.	Error location	Error handling	Emergency code CiA402
	MON_MotTemp	above threshold value	
(2)	(2) OvertempMotor_MON_Device_DIN1	PTC to DIN1	0x4310
(3)	(3) OvertempMotor_MON_Device_DIN2	PTC to DIN2	0x4310
(4)	(4) OvertempMotor_MON_Device_DIN3	PTC to DIN3	0x4310
7	Heat sink overheating		
(1)	(1) OvertempInverter_MON_Device	Heat sink temperature too high	0x4210
8	Interior overheating		
(1)	(1) OvertempDevice_MON_Device	Interior temperature monitor	0x4210
9	I²x t motor		
(1)	(1) I ² x tMotor_MON_I2t	I ² x t integrator has exceeded motor protection limit value (permissible current/time area)	0x2350
10	Power stage monitoring		
(1)	(1) I ² xt PowerAmplifier_MON_Device	I ² x t power stage protection limit value exceeded	0x2350

Error No.	Error location	Error handling	Emergency code CiA402
(2)	(2) Internal brake resistor was overloaded	The internal braking resistor was overloaded	
11	External error		
(1)	(1) External_MPRO_INPUT	External error message	0xFF0
12	CAN		
(1)	(1) ComOptCan_BusOff	CAN option: BusOff error	0x8140
(2)	(2) ComOptCan_Guarding	CAN option: Guarding error	0x8130
(3)	(3) ComOptCan_MsgTransmit	CAN option: Unable to send message	0x8100
(4)	(4) ComOptCan_HeartBeat	CAN option: Heartbeat error	0x8130
(5)	(5) ComOptCan_Addr	CAN option: Invalid address	0x8110
(6)	(6) ComOptCan_PdoMappingError	CAN option: Mapping error	0x8200
(7)	(7) ComOptCan_SyncTimeoutError	CAN option: Synchronization error	0x8140
13	SERCOS		
(1)	(1) ComOptSercos_HardwareInit	SERCOS: Hardware initialization	0xFF00
(2)	(2) ComOptSercos_		0xFF00

Error No.	Error location	Error handling	Emergency code CiA402
	IllegalPhase		
(3)	(3) ComOptSercos_CableBreak		0xFF00
(4)	(4) ComOptSercos_DataDisturbed		0xFF00
(5)	(5) ComOptSercos_MasterSync		0xFF00
(6)	(6) ComOptSercos_MasterData		0xFF00
(7)	(7) ComOptSercos_Address- Double		0xFF00
(8)	(8) ComOptSercos_PhaseSwitchUp		0xFF00
(9)	(9) ComOptSercos_PhaseSwitchDown	SERCOS: Faulty phase switching (Down shift)	0xFF00
(10)	(10) ComOptSercos_PhaseSwitchAck	SERCOS: Faulty phase switching (missing acknowledgement)	0xFF00
(11)	(11) ComOptSercos_InitParaList	SERCOS: Faulty initialization of SERCOS parameter lists	0xFF00
(12)	(12) ComOptSercos RunTimeError	SERCOS: Various runtime errors	0xFF00
(13)	(13) ComOptSercos_	SERCOS: Hardware watchdog	0xFF00

Error No.	Error location	Error handling	Emergency code CiA402
	Watchdog		
(14)	(14) ComOptSercos_Para	SERCOS: Error in parameterization (selection of OP mode, IP times, etc...)	0xFF00
14	EtherCat:		
(1)	(1) ComOptEtherCat_Sm_Watchdog0	EtherCat: Sync-Manager0 - Watchdog	0x8130
(2)	(2) ComOptEtherCat_Wrong EepData	EtherCat: Parameter error, parameter data implausible	0x8130
(3)	(3) ComOptEtherCat_RamError	EtherCat: Internal RAM error	0x8130
15	Parameter		
(1)	(1) Parameter_MON_Device_Current	Error in current monitoring initialization	0x2350
(2)	(2) ComOptEtherCat_Wrong EepData	EtherCat: Parameter error, parameter data implausible	0x2350
(3)	(3) ComOptEtherCat_RamError	EtherCat: Internal RAM error	0xFF00
(4)	(4) Parameter_CON_FM	Field model	0xFF00
(5)	(5) Parameter_CON_Timing	Basic initialization of control	0xFF00
(6)	(6) Parameter_MPRO_	Error calculating user units	0x6320

Error No.	Error location	Error handling	Emergency code CiA402
	FG		
(7)	(7) Parameter_ENC_RATIO	Error initializing encoder gearing	0x6320
(8)	(8) Parameter_Nerf	Speed recording / Observer	0x8400
(9)	(9) Parameter_ObsLib	Error in matrix library	0xFF0
(10)	(10) Parameter_CON_CCON	Torque control	0x8300
(11)	(11) Parameter_reserved1	Not used	0xFF00
(12)	(12) Parameter_Inertia	Moment of inertia is zero	0xFF00
(13)	(13) Parameter_MPRO	PARA_WatchDog in control via user user interface	0xFF00
(14)	(14) Parameter_DV_INIT	DV_INIT: Error in system initialization	0xFF00
16	Speed tracking error		
(1)	(1) SpeedDiff_MON_SDiff	Speed tracking error above threshold value	0x8400
(2)	(2) SpeedDiff_MON_NAct	Current speed above maximum speed of motor > 120%	0x8400
17	Position tracking error		

Error No.	Error location	Error handling	Emergency code CiA402
(1)	(1) PositionDiff_MON_ActDelta	Position tracking error too large	0x8611
18	Motion profile		
(1)	(1) MotionControl_MC_HOMING_LimitSwitchInterchanged	Homing: Limit switches interchanged	0x8612
(2)	(2) MotionControl:MC_HOMING: Unexpected home switch event	Homing: Limit switch tripped unexpectedly	0x8612
(3)	(3) MotionControl_MC_HOMING_ErrorLimitSwitch	Homing: Limit switch error	0x8612
(4)	(4) MotionControl_MC_HOMING_UnknownMethod	Homing: Wrong homing method, homing method not available	0x8612
(5)	(5) MotionControl_MC_HOMING_MethodUndefined	Homing: Homing method available but not defined	0xFF00
(6)	(6) MotionControl_MC_HOMING_DriveNotReadyHoming	Homing: Drive not ready for homing: Error is triggered when the motor is not stopped, or the standstill bit is not set (Standstill window).	0xFF00
(7)	(7) MotionControl_MC_	Homing: Drive not ready for	0xFF00

Error No.	Error location	Error handling	Emergency code CiA402
	HOMING_DriveNotReadyJogging	jog mode	
(8)	(8) MotionControl_MC_HOMING_WrongConMode	Homing: Control mode does not match homing method	0xFF00
(9)	(9) MotionControl_MC_HOMING_EncoderInitFailed	Homing: Encoder initialization error	0xFF00
(10)	(10) MotionControl_MC_HOMING_MaxDistanceOverrun	Homing: Homing travel exceeded	0xFF00
(11)	(11) MotionControl_MPRO_REF_EnabledOperationFailed	Max. permissible tracking error on "Start control" exceeded	0xFF00
(12)	(12) MotionControl_MPRO_REF_SSP_StackOverflow	Memory overflow for table values	0xFF00
(13)	(13) MotionControl_MC_HOMING_RestoreBackupPos	Error initializing last actual position after restart.	0xFF00
19	Fatal Error		
(1)	(1) FatalError_PowerStage_Limit_Idx	PST: Data index too large	0x5400
(2)	(2) FatalError_	PST: Error in switching	0x5400

Error No.	Error location	Error handling	Emergency code CiA402
	PowerStage_SwitchFreq	frequency-dependent data	
(3)	(3) FatalError_PowerStage_DataInvalid	PST: Invalid EEPROM data	0x5400
(4)	(4) FatalError_PowerStage_CRC	PST: CRC error	0x5400
(5)	(5) FatalError_PowerStage_ErrorReadAccess	PST: Error reading power stage data	0x5400
(6)	(6) FatalError_PowerStage_ErrorWriteAccess	PST: Error writing power stage data	0x5400
(7)	(7) FatalError_MON_Chopper	Current in braking resistor even though transistor switched off	0x5420
(8)	(8) FatalError_HW_Identification	Hardware identification error	0x5300
(9)	(9) FatalError_FlashMemory	Error in flash memory	0x5300
20	Hardware limit switches		
(1)	(1) HardwareLimitSwitch_Interchanged	Limit switches interchanged	0x8612

Error No.	Error location	Error handling	Emergency code CiA402
(2)	(2) HardwareLimitSwitch_LCW	Positive limit switch	0x8612
(3)	(3) HardwareLimitSwitch_LCCW	Negative limit switch	0x8612
21	Encoder initialization	General encoder initialization (locations which cannot be assigned to a channel)	
(1)	(1) EncoderInit_CON_ICOM_EpsDelta	Encoder general initialization: Autocommutation: excessive motion	0x7300
(2)	(2) EncoderInit_CON_ICOM_Tolerance	Encoder general initialization: Autocommutation: excessive tolerance	0x7300
22	Encoder channel 1 initialization		
(1)	(1) EncCH1Init_Sincos_Lines	Encoder channel 1 initialization, Sincos: Plausibility check 'Lines' from PRam_ENC_CH1_Lines	0x7305
(2)	(2) EncCH1Init_Sincos_ABSquareSum	Encoder channel 1 initialization, Sincos: Getting AB-SquareSum, Timeout	0x7305
(3)	(3) EncCH1Init_Sincos_	Encoder channel 1	0x7305

Error No.	Error location	Error handling	Emergency code CiA402
	EncObs	initialization, SinCos: Encoder monitoring Sincos	
(4)	(4) EncCH1Init_EnDat2.1_NoEnDat2.1	Encoder channel 1 initialization, EnDat2.1: No EnDat2.1 encoder (encoder may be SSI)	0x7305
(5)	(5) EncCH1Init_EnDat2.1_Line5	Encoder channel 1 initialization, EnDat2.1: Plausibility check 'Lines' from encoder	0x7305
(6)	(6) EncCH1Init_EnDat2.1_Multiturn	Encoder channel 1 initialization, EnDat2.1: Plausibility check 'Multiturn' from encoder	0x7305
(7)	(7) EncCH1Init_EnDat2.1_Singleturn	Encoder channel 1 initialization, EnDat2.1: Plausibility check 'Singleturn' from encoder	0x7305
(8)	(8) EncCH1Init_EnDat2.1_CrcPos	Encoder channel 1 initialization, EnDat2.1: CRC error position transfer	0x7305
(9)	(9) EncCH1Init_EnDat2.1_CrcData	Encoder channel 1 initialization, EnDat2.1: CRC error data transfer	0x7305
(10)	(10) EncCH1Init_EnDat2.1_WriteToProt	Encoder channel 1	0x7305

Error No.	Error location	Error handling	Emergency code CiA402
		initialization, EnDat2.1: An attempt was made to write to the protection cells in the encoder!	
(11)	(11) EncCH1Init_EnDat2.1_SscTimeout	Encoder channel 1 initialization, EnDat2.1: Timeout on SSC transfer	0x7305
(12)	(12) EncCH1Init_EnDat2.1_StartbitTimeout	Encoder channel 1 initialization, EnDat2.1: Timeout, no start bit from encoder	0x7305
(13)	(13) EncCH1Init_EnDat2.1_PosConvert	Encoder channel 1 initialization, EnDat2.1: Position data not consistent	0x7305
(14)	(14) EncCH1Init_SSI_Lines	Encoder channel 1 initialization, SSI: Plausibility check 'Lines' from encoder	0x7305
(15)	(15) EncCH1Init_SSI_Multiturn	Encoder channel 1 initialization, SSI: Plausibility check 'Multiturn' from encoder	0x7305
(16)	(16) EncCH1Init_SSI_Singleturn	Encoder channel 1 initialization, SSI: Plausibility check 'Singleturn' from encoder	0x7305

Error No.	Error location	Error handling	Emergency code CiA402
(17)	(17) EncCH1Init_SSI_ParityPos	Encoder channel 1 initialization, SSI: Parity error position transfer	0x7305
(18)	(18) EncCH1Init_SSI_SscTimeout	Encoder channel 1 initialization, SSI: Timeout on SSC transfer	0x7305
(19)	(19) EncCH1Init_SSI_PosConvert	Encoder channel 1 initialization, SSI: Position data not consistent	0x7305
(20)	(20) EncCH1Init_SSI_EncObs	Encoder channel 1 initialization, SSI: Encoder monitoring bit	0x7305
(21)	(21) EncCH1Init_Hiperface_NoHiperface	Encoder channel 1 error initializing Hiperface interface	0x7305
(22)	(22) EncCH1Init_Hiperface_Common	Encoder channel 1 initialization, Hiperface: Interface, general error	0x7305
(23)	(23) EncCH1Init_Hiperface_Timeout	Encoder channel 1 initialization, Hiperface: Interface, Timeout	0x7305
(24)	(24) EncCH1Init_Hiperface_CommandMismatch	Encoder channel 1 initialization, Hiperface: Encoder, impossible COMMAND in response	0x7305
(25)	(25) EncCH1Init_	Encoder channel 1	0x7305

Error No.	Error location	Error handling	Emergency code CiA402
	Hiperface_EStatResp_Crc	initialization, Hiperface: CRC error in error status response	
(26)	(26) EncCH1Init_Hiperface_EStatResp_Com	Encoder channel 1 initialization, Hiperface: Error status response returns communication error	0x7305
(27)	(27) EncCH1Init_Hiperface_EStatResp_Tec	Encoder channel 1 initialization, Hiperface: Error status response returns technology or process error	0x7305
(28)	(28) EncCH1Init_Hiperface_EStatResp_None	Encoder channel 1 initialization, Hiperface: Error status response returns no error(!)	0x7305
(29)	(29) EncCH1Init_Hiperface_Response_Crc	Encoder channel 1 initialization, Hiperface: CRC error in response	0x7305
(30)	(30) EncCH1Init_Hiperface_Response_Com	Encoder channel 1 initialization, Hiperface: Response with error bit: Status returns communication error	0x7305
(31)	(31) EncCH1Init_Hiperface_Response_Tec	Encoder channel 1 initialization, Hiperface: Response with error bit: Status returns technology or	0x7305

Error No.	Error location	Error handling	Emergency code CiA402
		process error	
(32)	(32) EncCH1Init_Hiperface_Response_None	Encoder channel 1 initialization, Hiperface: Response with error bit: Status returns no error	0x7305
(33)	(33) EncCH1Init_Hiperface_Status_Com	Encoder channel 1 initialization, Hiperface: Status telegram reports communication error	0x7305
(34)	(34) EncCH1Init_Hiperface_Status_Tec	Encoder channel 1 initialization, Hiperface: Status telegram returns technology or process error	0x7305
(35)	(35) EncCH1Init_Hiperface_TypeKey	Encoder channel 1 initialization, Hiperface: Type identification of encoder unknown	0x7305
(36)	(36) EncCH1Init_Hiperface_WriteToProt	Encoder channel 1 initialization, Hiperface: An attempt was made to write to the protection cells in the encoder!	0x7305
(37)	(37) EncCH1Init_TTL_IncompatibleHardware	Encoder channel 1 initialization, TTL: Control pcb does not support TTL evaluation	0x7305

Error No.	Error location	Error handling	Emergency code CiA402
(38)	(38) EncCH1Init_EnDat2.1_PositionBits	Encoder channel 1 initialization, EnDat2.1: Plausibility check 'Position Bits' from encoder	0x7305
(39)	(39) EncCH1Init_EnDat2.1_TransferBits	Encoder channel 1 initialization, EnDat2.1: Plausibility check 'Transfer Bits' of transfer	0x7305
(40)	(40) EncCH1Init_Np_NominalIncrement	Encoder channel 1 initialization, NP: Plausibility check 'Lines' and 'Nominal-Increment'	0x7305
(41)	(41) EncCh1Init_Endat21_Common	Encoder channel 1 initialization, Endat2.1: Interface general error	0x7305
(42)	(42) EncCh1Init_SSI_Common	Encoder channel 1 initialization, SSI: Interface general error	0x7305
(43)	(43) EncCh1Init_Sincos_Common	Encoder channel 1 initialization, Sincos: Interface general error	0x7305
23	Initialization Encoder channel 2		
(1)	(1) EncCH2Init_Res_Lines	Encoder channel 2 initialization, Res: Plausibility	0x7306

Error No.	Error location	Error handling	Emergency code CiA402
		check 'Lines' from PRam_ENC_CH2_Lines	
(2)	(2) EncCH2Init_Res_ABSquareSum_TimeOut	Encoder channel 2 initialization, Res: Getting ABSquareSum, Timeout	0x7306
(3)	(3) EncCH2Init_Res_EncObs	Encoder channel 2 initialization, Res: Encoder monitoring resolver	0x7306
24	Encoder channel 3 initialization		
(1)	(1) EncCH3Init_ModuleIdentificationFailed	Encoder channel 3 initialization: No module inserted or wrong module	0x7307
(2)	(2) EncCH3Init_Common_EO_Error	Encoder channel 3 initialization: General EO error (encoder option)	0x7307
(3)	(3) EncCH3Init_SSI_EncObs_20c	Encoder channel 3 initialization: Encoder monitoring	0x7307
(4)	(4) EncCH3Init_EnDat2.1_NoEnDat2.1	Encoder channel 3 initialization, EnDat2.1: No EnDat2.1 encoder (encoder may be SSI)	0x7307
(5)	(5) EncCH3Init_EnDat2.1_Lines	Encoder channel 3 initialization, EnDat2.1:	0x7307

Error No.	Error location	Error handling	Emergency code CiA402
		Plausibility check 'Lines' from encoder	
(6)	(6) EncCH3Init_EnDat2.1_Multiturn	Encoder channel 3 initialization, EnDat2.1: Plausibility check 'Multiturn' from encoder	0x7307
(7)	(7) EncCH3Init_EnDat2.1_Singleturn	Encoder channel 3 initialization, EnDat2.1: Plausibility check 'Singleturn' from encoder	0x7307
(8)	(8) EncCH3Init_EnDat2.1_CrcPos	Encoder channel 3 initialization, EnDat2.1: CRC error position transfer	0x7307
(9)	(9) EncCH3Init_EnDat2.1_CrcData	Encoder channel 3 initialization, EnDat2.1: CRC error data transfer	0x7307
(10)	(10) EncCH3Init_EnDat2.1_WriteToProt	Encoder channel 3 initialization, EnDat2.1: An attempt was made to write to the protection cells in the encoder!	0x7307
(11)	(11) EncCH3Init_EnDat2.1_SscTimeout	Encoder channel 3 initialization, EnDat2.1: Timeout on SSC transfer	0x7307
(12)	(12) EncCH3Init_	Encoder channel 3	0x7307

Error No.	Error location	Error handling	Emergency code CiA402
	EnDat2.1_StartbitTimeout	initialization, EnDat2.1: Timeout, no start bit from encoder	
(13)	(13) EncCH3Init_EnDat2.1_PosConvert	Encoder channel 3 initialization, EnDat2.1: Position data not consistent	0x7307
(14)	(14) EncCH3Init_SSI_Lines	Encoder channel 3 initialization, SSI: Error initializing SSI interface	0x7307
(14)	(15) EncCH3Init_SSI_Multiturn	Encoder channel 3 initialization, SSI: Plausibility check 'Multiturn' from encoder	0x7307
(16)	(16) EncCH3Init_SSI_Singleturn	Encoder channel 3 initialization, SSI: Plausibility check, Singleturn from encoder	0x7307
(17)	(17) EncCH3Init_SSI_ParityPos	Encoder channel 3 initialization, SSI: Parity error position transfer	0x7307
(18)	(18) EncCH3Init_SSI_SscTimeout	Encoder channel 3 initialization, SSI: Timeout on SSC transfer	0x7307
(19)	(19) EncCH3Init_SSI_PosConvert	Encoder channel 3 initialization, SSI: Position data not consistent	0x7307

Error No.	Error location	Error handling	Emergency code CiA402
(20)	(20) EncCH3Init_SSI_ EncObs	Encoder channel 3 initialization, SSI: Encoder monitoring bit	0x7307
(38)	(38) EncCH3Init_ EnDat2.1_PositionBits	Encoder channel 3 initialization, EnDat2.1: Plausibility check 'Position Bits' from encoder	0x7307
(39)	(39) EncCH3Init_ EnDat2.1_TransferBits	Encoder channel 3 initialization, EnDat2.1: Plausibility check 'Transfer Bits' of transfer	0x7307
(40)	(40) EncCH3Init_Np_NominalIncrement	Encoder channel 3 initialization, NP: Plausibility check "Lines" and 'Nominal-Increment'	0x7307
(41)	(41) EncCH3Init_ Endat21_Common	Encoder channel 3 initialization, EnDat2.1: Interface, general error	0x7307
(42)	(42) EncCH3Init_SSI_Common	Encoder channel 3 initialization, SSI: Interface, general error	0x7307
(43)	(43) EncCH3Init_Sincos_Common	Encoder channel 3 initialization, Sincos: Interface, general error	0x7307
(50)	(50) EncCH3Init_TOPT_	Encoder channel 3	0x7307

Error No.	Error location	Error handling	Emergency code CiA402
	cfg	initialization, interface, general error	
25	EncoderCycl	Autocommutation	
(1)	(1) EncoderCycl_CON_ICOM_Epsdelta	Autocommutation: excessive motion	0xFF00
(2)	(2) EncoderCycl_CON_ICOM_Tolerance	Autocommutation: Excessive tolerance (P 394)	0xFF00
26	EncCh1Cycl	Plausibility check CH1	
(1)	(1) EncCH1Cycl_Np_Distance	Encoder channel 1 cyclic, NP: Plausibility check 'CounterDistance';	0x7305
(2)	(2) EncCH1Cycl_Np_DeltaCorrection	Encoder channel 1 cyclic, NP: Delta correction not possible	0x7305
(3)	(3) EncCH1Cycl_Np_Delta	Encoder channel 1 cyclic, NP: Plausibility check 'CounterDelta';	0x7305
27	EncCh2Cycl	Plausibility check CH2	
(1)	(1) EncCH2Cycl_NoLocation	Not used	0x7306
28	EncCh3Cycl	Plausibility check CH3	
(1)	(1) EncCH3Cycl_NoLocation	Not used	0x7307

Error No.	Error location	Error handling	Emergency code CiA402
29	TC (TriCore)		
(1)	(1) TC_ASC	TriCore ASC	0x5300
(2)	(2) TC_ASC2	TriCore ASC2	0x5300
(3)	(3) TC_FPU	TriCore floating point error	0x5300
(4)	(4) TC_FPU_NO_RET_ADDR	TriCore floating point error, no return address available	0x5300
30	InitCon	Initialization error	
(1)	(1) InitCon_AnaInput	Initialization error analog input	0x5300
(2)	(2) InitCon_FM_GetKM	Initialization error calculating motor torque constant	0x5300
(3)	(3) InitCon_FM_ASM	Initialization error asynchronous motor	0x5300
(4)	(4) InitCon_FM_ASM_FW	TriCore floating point error, no return address available	0x5300
31	PLC		
(1)	(1) PLC_Location 0...65536	User-specific: Errors generated in PLC program	0xFF00
32	Profibus		
(1)	(1) ComOptDp_Timeout	PROFIBUS DP: Process data Timeout	0xFF00

Error No.	Error location	Error handling	Emergency code CiA402
33	Timing	Task overflow	
(1)	1) Timing_ADCTask_ReEntry	ADC task automatically interrupted	0x5300
(2)	(2) Timin_ControlTask	Control task exceeded scan time	0x5300
34	PowerFail	Power failure detection	
(1)	PowerFail	Power failure detection; supply voltage error	0x3220
35	EncObs	Encoder wire break	
(1)	(1) EncObs_CH1_Sincos	Wire break: Encoder channel 1	0xFF00
(2)	(2) EncObs_CH2_Resolver	Wire break: Encoder channel 2	0xFF00
(3)	(3) EncObs_CH3_Sincos	Wire break: Encoder channel 3	0xFF00
(4)	(4) EncObs_CH1_SSI	Wire break: Encoder channel 1	0xFF00
36	VARAN		
(1)	(1) ComOptVARAN_InitHwError	Error in hardware initialization: VARAN option	0x5300
(2)	(2) ComOptVARAN_BusOffError	"Bus off" error; no bus communication: VARAN	0x5300

Error No.	Error location	Error handling	Emergency code CiA402
		option	
37	Synchronization controller		
(1)	(1) RatioError	The ratios between interpolation, synchronization and/or speed control time do not match	0x6100
38	Brake chopper monitoring		
(1)	(1) BC_Overload	Brake chopper overloaded	0x4210
39	TwinWindow	Monitoring of speed and torque	
(1)	(1) TwinWindow_Speed	Speed deviation between Master and Slave	
(2)	(2) TwinWindow_Torque	Torque deviation between Master and Slave	
40	Twin-Sync-Module	Communication error TECH option	
(1)	(1) TOPT_TWING_CommLost	Error in "TwinSync" technology option	0x7300
(2)	(2) TOPT_TWING_SwitchFreq	Error in "TwinSync" technology option	0x7300
(3)	(3) TOPT_TWING_	Error in "TwinSync"	0x7300

Error No.	Error location	Error handling	Emergency code CiA402
	ModeConflict	technology option	
(4)	(4) TOPT_TWING_RemoteError	Error in "TwinSync" technology option	0x7300
41	DC link fast discharge	Maximum period for fast discharge	
(1)	(1) FastDischarge_Timeout	Maximum period for fast discharge exceeded (35 s)	0x7300
42	EtherCAT Master Implementation	Error EtherCat Master	
(1)	(1) Location can not specified CommError	Communication error EtherCat Master, cannot be localized.	0x6100
43	Ethernet port	Error in Ethernet configuration	
(1)	(1) Ethernet_Init	Initialization error TCP/IP communication	0x6100
44	Wire break detected		
(1)	(1) WireBreak_MotorBrake	No consumer on output X13 (motor holding brake)	0x6100
45	LERR_LockViolate		
(1)	(1)LERR_LockViolate	Movement requested which was limited by reversing lock, limit switch or reference value	0x8612

Error No.	Error location	Error handling	Emergency code CiA402
		limitation	
(2)	(2)LERR_LockViolate	Movement requested which was limited by reversing lock, limit switch or reference value limitation. Lock active in both directions	0x8612
46	LERR_positionLimit		
(1)	(1) Position Limit_neg.	Negative software limit switch approached	0x8612
(2)	(2) Position Limit_pos	Positive software limit switch approached	0x8612
(3)	(3) Position Limit_Overtravel	Reference value outside software limit switches	0x8612
47	FSAFE functional safety		
(1)	(1) Communication TC SMC	Communication between Tricore processor (TC) and SMC module	
(2)	(2)TC-command-interface to SMC	Command interface to SMC module	
(3)	PLC-application file (download)	Download error	
(4)	PLC-application file (upload)	Upload error	

Error No.	Error location	Error handling	Emergency code CiA402
(5)	Generating alarm- or errormessages from Safety-System	Error message from safety system	
(6)	messages from safety-system	Warning message from safety system	
(7)	Mismatch between power-stage-data on TC and Safety-System	Power stage parameters of Tricore processor do not match safety system	
48	FSAFE Safety-System	Safety system	
(1)	Alarm on SMC (MCO , System_A)	Alarm_MCO_A	
(2)	Alarm on SMC (MCO , System_B)	Alarm_MCO_B	
(3)	Alarm on SMC (SCO_1, System_A)	Alarm_SCO1_A	
(4)	Alarm on SMC (SCO_1, System_B)	Alarm_SCO1_B	
(5)	Alarm on SMC (SCO_2, System_B)	Alarm_SCO2_A	
(6)	Alarm on SMC (SCO_2, System_B)	Alarm_SCO2_B	
(7)	Alarm on SMC (SCO_3, System_A)	Alarm_SCO3_A	

Error No.	Error location	Error handling	Emergency code CiA402
(8)	Alarm on SMC (SCO_3, System_B)	Alarm_SCO3_B	
(9)	Alarm on SMC (SCO_4, System_A)	Alarm_SCO4_A	
(10)	Alarm on SMC (SCO_4, System_B)	Alarm_SCO4_B	
(11)	Alarm on SMC (SCO_5, System_A)	Alarm_SCO5_A	
(12)	Alarm on SMC (SCO_5, System_B)	Alarm_SCO5_B	
(13)	Error on SMC (System_A)	Error_A	
(14)	Error on SMC (System_B)	Error_B	
49	LERR_NmtStateChange	NMT state change while drive in closed-loop control.	
(1)	NMT: Operational state lost while control is running		
50	TimeOut detected;	Timeout	
(1)	Allowed duration of negative speed in control exceeded	Permitted duration for closed-loop control exceeded	

Error No.	Error location	Error handling	Emergency code CiA402
51	LERR_EncStatus	Warning or error bits in digital encoder log	
(1)	EncStatus_CH1	Status scan CH1	
(2)	EncStatus_CH3	Status scan CH2	
52	LERR_ANA: Analog inputs	Wire break detection, analog inputs	
(1)	Wire break detection	Wire break on analog inputs	
53	LERR_MotorFailure	Motor phase error	
(1)	loss of motor phase detected	At least one motor phase missing	
54	power grid failure	Mains phase error	
(1)	loss of power grid phase detected	Missing mains phase	
55	speed guarding error	Speed monitoring	
(1)	maximum speed deviation detected	Maximum speed deviation detected.	

Tabelle 9.2.1 Error messages

9.3 Error reactions

9.3.1 Assignment of error reactions

Each of the errors listed in parameter **P 0030 Error Reaction** (index 0-47) can be assigned one of the error reactions listed below.

Parameters

P. no.	Parameter name/ Settings	Function
P 0030	ErrorReactions	Programmable error reaction
(0)	Ignore	Ignore error: Exception: In the case of the HW limit switch a warning is generated (P 0034 bit 29 or bit 30)
(1)	Specific1	Report error: Reaction is executed by external controller. Error reaction is terminated by iPLC function block. Exception: In the case of the HW limit switch a warning is generated (P-0034 bit 29 or bit 30) and a HALT request (brake with ramp dependent on HALT option code, without changing DRIVECOM system state). At standstill the relevant direction is blocked as long as the limit switch is active.
(2)	Specific 2	Report error: Reaction is executed by iPLC Error reaction is executed according to

P. no.	Parameter name/ Settings	Function
		the preset "Specific2 error option code" (P 0038). Settings: <ul style="list-style-type: none"> • DisableDriveFunction 0: disable drive, motor is free to rotate • ExtDisableStandstill -1: external reaction disable drive at standstill or timeout (P 0154) • ExtDisableTimeout -2: external reaction disable drive at timeout (P 0154) • PlcDisableTimeout -3: iPLC reaction, disable drive at timeout (P 0154) • PlcDisable -4: iPLC reaction
(3)	FaultReactionOptionCode	Report error: Reaction dependent on "Fault reaction codes"
(4)	ServoStop	Report error: Execute quick-stop and wait for control to restart.
(5)	ServoStopAndLock	Report error: Execute quick-stop, switch off power stage. Protection against restart.
(6)	ServoHalt	Report error: Switch off power stage
(7)	ServoHaltAndLock	Report error: Switch off power stage, protection against restart

P. no.	Parameter name/ Settings	Function
(8)	WaitERSAndReset	Report error: Switch off power stage, reset error (only by 24 V control voltage Off/On)

Tabelle 9.3.1 Error reactions

[Error list.htm](#)

Siehe "Error list" auf Seite 216

9.4 Warning thresholds

9.4.1 Defining thresholds

To avoid false alarms, you can define warning thresholds. Each warning is assigned on and off thresholds. This enables parameterization of a hysteresis meeting the requirement of the application. When a warning is triggered, the corresponding bit is entered in parameter **P 0034 ERR_WRN_State**. The binary value enables a status interrogation. Warnings can also be programmed onto digital outputs.

Before an error is triggered, warning thresholds can be defined with **P 0730 MON_WarningLevel**.

Device warning

P 0034 Bit no.	Device warning status word
(0)	I ² xt integrator (motor) warning threshold exceeded
(1)	Heat sink temperature

P 0034 Bit no.	Device warning status word
(2)	Motor temperature
(3)	Interior temperature
(4)	Reserved for SERCOS
(5)	Overspeed
(6)	Reserved for SERCOS
(7)	Reserved for SERCOS
(8)	Reserved for SERCOS
(9)	Undervoltage
(10)	Reserved for SERCOS
(11)	Reserved for SERCOS
(12)	Reserved for SERCOS
(13)	Reserved for SERCOS
(14)	Reserved for SERCOS
(15)	Reserved for SERCOS
(16)	I ² xt integrator (device) exceeded
(17)	Monitoring of apparent current
(18)	Overvoltage
(19)	Protection of brake chopper, warning threshold exceeded
(20)	Overtorque

P 0034 Bit no.	Device warning status word
(21)	Reserve
(22)	Reserve
(23)	Reserve
(24)	Speed reference limitation active
(25)	Current reference limitation
(26)	Right limit switch active
(27)	Left limit switch active
(28)	External warning via input
(29)	Reserve
(30)	Reserve
(31)	Reserve

Tabelle 9.4.1 Device warning status word

Adaptation of switching hysteresis (warning thresholds):

No message is issued in the hysteresis range. So when a warning is parameterized the hysteresis window must be adapted for the corresponding warning. The upper and lower limits of the window must be programmed.

P. no. P 0730	Parameter name	Threshold name	Status
(0)	UnderVoltage_ON	Undervoltage	It is

P. no. P 0730	Parameter name	Threshold name	Status
(1)	UnderVoltage_OFF	Undervoltage	Off
(2)	OverVoltage_ON	Overvoltage	It is
(3)	OverVoltage_OFF	Overvoltage	Off
(4)	Current_ON	Motor current	It is
(5)	Current_OFF	Motor current	Off
(6)	Device I ² xt_ON	I ² xt device protection	It is
(7)	Device I ² xt_OFF	I ² xt device protection	Off
(8)	Motor I ² xt_ON	I ² xt motor protection	It is
(9)	Motor I ² xt_OFF	I ² xt motor protection	Off
(10)	Torque ON	Torque limit reached	It is
(11)	Torque OFF	Torque limit reached	Off
(12)	Speed ON	Speed limit reached	It is
(13)	Speed OFF	Speed limit reached	Off
(14)	TC ON	Heat sink temperature reached	It is
(15)	TC OFF	Heat sink temperature reached	Off
(16)	T_int ON	Housing internal temperature reached	It is
(17)	T_int OFF	Housing internal temperature reached	Off
(18)	MotorTemp_ON	Motor temperature reached (temperature sensor on X5)	It is

P. no. P 0730	Parameter name	Threshold name	Status
(19)	MotorTemp_OFF	Motor temperature reached (temperature sensor on X5)	Off
(20)	MotorTemp_ON X6	Motor temperature reached (temperature sensor on X6)	It is
(21)	MotorTemp_OFF X6	Motor temperature reached (temperature sensor on X6)	Off

Tabelle 9.4.2 Warning thresholds overview

[Error reactions.htm](#)

9.5 Warning status window

9.5.1 Warnings

The "Warning status" window is opened by clicking the "Warnings" pictogram on the quick-launch toolbar. As soon as a warning occurs, it is displayed in the "Warning status" dialog box. The trigger threshold is set in parameter **P 0730 MON_WarningLevel**.



Bild 9.5.1 Warning status window

10 Field buses

Information	
Navigation	Project tree < Device setup < Field buses
Pictograms	No pictogram available
Contents	<ul style="list-style-type: none"> • Profibus.htm • CANopen.htm • SERCOS.htm
	For more information refer to the user manuals for the individual bus systems.

Tabelle 10.0.1 Field buses subject area

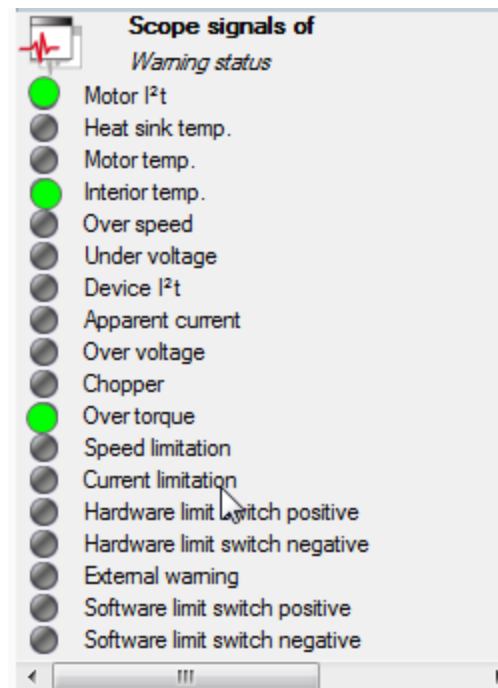
10.1 Profibus

10.1.1 Short description of PROFIBUS DP interface

The implementation in the controller is based on the PROFIdrive profile version 4.0.

- Data transmission using two-wire twisted pair cable (EIA 485)
- Transmission as differential signal
- Transfer rate: max. 12 MBaud
- Device definition via GSD file (device master file)
- Automatic baud rate detection
- PROFIBUS address can be set using the rotary coding switches or alternatively using the addressing parameters
- Cyclic data exchange reference and actual values using DPV0
- Acyclic data exchange using DPV1
- Synchronization of all connected drives using freeze mode and sync mode
- Reading and writing drive parameters using the PKW channel or DPV1
- Termination with terminating resistor (220 Ohm) at bus-end
- Master/slave system



NOTE:

For a detailed description of the PROFIBUS field bus system refer to the separate "Profibus User Manual".

10.2 PROFINET

The "PROFINET" field bus system permits enhanced system-wide connectivity, adding to tried and proven PROFIBUS technology for applications specifying fast data communication in combination with industrial IT functionality. Thanks to its Ethernet-based communication, PROFINET meets a wide range of requirements, from data-intensive parameter assignments to synchronised data transfer. Communication for all applications is routed through just one cable. Whether for a simple control task or for highly dynamic motion control of drive axes. TCP/IP-based communication in the PROFINET network enabling extensive system diagnostics in a control station or over the Internet is implemented in parallel with real-time communication.

For more information refer to the user manual.S08_PROFIBUS_PROFINET_BenHB_11_2012_DE

10.3 CANopen, EtherCAT

The CANopen communication profile is documented in CiA301. It differentiates between Process Data Objects (PDOs) and Service Data Objects (SDOs). The Communication Profile additionally defines a simplified network management system. Based on the communication services of CiA 301 (Rev. 4.01) the device profile for variable-speed drives CiA 402 was created. It describes the operation modes and device parameters supported.

- Master/slave system
- Assignment of device addresses (NodeID)
- Differential signals for transmission

- 120 Ohm bus termination on both ends
- 24V external bus supply
- Transfer rate up to 1 MBaud
- DS301 specification
- Unconfirmed and confirmed transfer services (PDO & SDO)
- Network management service (NMT)
- Error handling service (EMCY)
- Device description via EDS file

For EtherCAT communication CoE (CAN over EtherCAT) is used. In this, the EtherCAT real-time protocol is used as the transport system for another protocol. Other commonly used variants alongside CoE are SoE (Servodrive-Profile over EtherCAT), EoE (Ethernet over EtherCAT) and FoE (File Access over EtherCAT). EtherCAT features real-time capability, fast sampling times and exact synchronization based on the principle of distributed clocks in the slave devices.

**NOTE:**

For a detailed description of the CANopen field bus system refer to the separate "CANopen User Manual" and "CANopen EtherCAT User Manual".

**Attention:**

EtherCAT®

"EtherCAT® is a registered trademark and patented technology licensed by Beckhoff Automation GmbH, Germany."

10.4 SERCOS

We support SERCOS II and SERCOS III. This is a real-time capable master/slave communications system. The bus system is characterized by high sampling times and low jitter. The SERCOS II bus is implemented as a ring topology via fibre-optic cable. Fibre-optic technology minimizes electromagnetic disturbance over the bus. Reference input is entered cyclically on the servocontrollers. A torque, position or speed can be specified as a reference value.

In SERCOS III the physical transfer is executed over the Ethernet, and so is compatible with existing systems. The synchronization process has been enhanced over SERCOS II, and it offers extended device profiles. It also offers direct device-to-device cross-communication.

10.4.1 Features

General:

- Automatic baud rate detection
- Programmable SERCOS address via parameters!
- Use of device profiles with defined parameters
- Master/slave mode
- Free configuration of telegram content
- Master synchronization of all drives in the ring
- No bus termination required

SERCOS II:

- Fibre-optic transfer
- Ring topology
- Time slot method
- 254 stations per ring
- 2,4,8 or 16 Mbit/s

SERCOS III:

- Ethernet-based communication channel
- Collision-free real-time communication based on time slot method
- Hot-plug functionality
- Cross-communication among slaves or with PLC



NOTE:

For a detailed description of the SERCOS field bus system refer to the separate "SERCOS User Manual".

11 Technology option X8

Information	
Navigation	Project tree < Device setup < Technology options X8
Pictograms	
Contents	<ul style="list-style-type: none"> • Selection of modules.htm

Tabelle 11.0.1 Technology Option subject area

[Technology option X8](#)

11.1 Selection of modules

The option slot supports the following options:

- SinCos module
- TTL encoder/simulation
- TTL encoder with commutation signals
- SSI module
- TwinSync module

[Evaluatable encoder types.htm](#)

12 Index

A

Absolute value sender 57
ABSPOS 98
Acceleration weighting 134
Actual position 76
adaptation 94
Adaptation of mass inertia 88
Adaptation of torque control 93
Adaptation to the rigidity of the drive train 89
Advanced speed control (observer) 110
Alarm and warning 215
Analog channel 176
Analog input function selector 201
Analog outputs 204
Analysis of speed control 105

Anti-reverse mode 165, 168
AS motor 33
ASM characteristic 37
ASM field-weakening 116
Autocommutation for synchronous machines 122
Automatic tests 20
Autostart 195
Axis correction 76

C

Cam plate 173
CANopen, EtherCAT 237
Channel 1 Interface X7 46
channel 2 43
Channel 2 Resolver X6 43
Channel 3 X8 52
Characteristic setting 37
Closed-loop control 85
Commissioning wizard 17
Configuration of TTL encoder simulation and repeater mode 66
Control basic setting 86

Control location selector 191
Current controller optimization 90
Current/torque controller settings 90
Cyclic evaluation of digital encoders 51

D

Detent torque compensation 97
Determining mass inertia 89
Determining the direction of movement 78
Device and firmware variants 1
Device warning 233
Digital filters 107
Digital interface 53
Digital output function selectors 196
disable Operation 146
Disengagement variants 167
Display 216

E

Electronic gearing settings 163
encoder 42

Encoder channel X8 74
Encoder gearing 79
Encoder signal oversampling 81
Engagement and disengagement 166
EPMS 99
EPSRS 98
Error display 216
Error reactions 232
Evaluatable encoder types 53
Expanded 110

F

Fault 147
FaultReaction 147
Features of the TTL module 63
FFT signal analysis 109
Field-weakening of ASM voltage controller 117
Field buses 236
Filter coefficients 109
Filter combinations 107
Filters 113

Force/torque weighting 134
Friction torque compensation 114
Function of process controller 125
Function selector - digital inputs 192

G

General definition of interpolation 187
GPOC correction method 45, 50, 56

H

Halt 147
Halt Operation 147
Hardware enable 194
Hardware requirements 14, 17
Hexagon modulation 95
Hiperface 49
Homing 148
Homing method (-12) 149
Homing method 35 161
Homing methods (-10) and (-11) 150
Homing methods (-7) to (0) 152

Homing methods (-8) and (-9) 151
Homing methods 1 and 2 153
Homing methods 11-14 157
Homing methods 15 and 16 159
Homing methods 17-30 159
Homing methods 3 and 4 153
Homing methods 31 and 32 160
Homing methods 33 and 34 160
Homing methods 5 and 6 155
Homing methods 7 to 10 155

IECON(4) method 122

IENCC(1) method 122

Increment-coded reference marks 80

Index 242

Indexing table function "Infinite driving job" 142

Indexing table function "Relative driving job" 142

Indexing table function direction of rotation setting 140

Indexing table function path-optimized 141

Indexing table function setting "as linear" 139

Initial commissioning 13-14, 17

Initial commissioning – Linear system 17

Initial commissioning – Rotary system 14

Inputs/outputs 190

Interface configuration of encoder for closed-loop control 73

Interpolated mode (IP) and Profile Generator mode (PG) 202

Interpolation types 187

J

Jerk limitation 185

Jerk limitation and speed offset 185

Jog mode 161

Jog speed 162

K

K-T characteristic 94

L

LHMES(2) method 123

Limit switch and zero pulse 153

Limit value settings 210

Limitation by software limit switch 213

Limits and thresholds 209

Linear motor 31

Linear weighting 137

M

Master configuration 164

master encoder 164

Modulo weighting 137

Motion profile 130

Motion profile basic settings 142

Motion profile setting 131

Motor 27

Motor brake 205

Motor brake output 205

Motor calculation 29

Motor contactor 200

Motor control basic setting 88

Motor control setup 87

Motor identification 34

Motor protection 38

Motor, general 28

Multi-turn encoder as single-turn encoder 80

Multi-turn range 82

N

Negative reference cam and zero pulse 155

O

Observer 94

Optimizing the speed controller 104-105

Options 241

Overflow in multi-turn range 82

Overmodulation 95

Oversampling 82

P

Parameterization of SSI encoder simulation 60

Parameterization of the TTL encoder 65

Parameterization of the TTL encoder channel 68

Parameterization of TTL encoder channel with autocommutation 73

Parameterization of TTL encoder with commutation signals 73

PG mode 182

Phase shift of resolver signals 46

Pin assignment 44

Pin assignment for SSI encoder simulation 60

Pin assignment of TTL with commutation signals 71

Pin assignment X8 55

Pin assignment_TTL encoder 64

Polarity and phase 61

Position control in IP mode 185

Position control in PG mode 184

Position controller setup 112

Position limitation 212

Position polarity 136

Positioning jobs 174

Positive reference cam and zero pulse 153

Power-up sequence 195

Power failure 213

Power failure bridging 24

Power failure reaction 213-214

Power stage 22

Power stage setting 23

PRBS signal 100

Pre-control 113
Process controller setup 126
Profibus 237
Profile Generator 182, 184
PROFINET 237
PS linear motor 31
PS motor 29
PSM characteristic 35
PSM characteristic setting 35

Q

Quick-stop 145, 147

R

Ramps 174
Rate limiter 127
Reduktion 110
Reduktion der Geschwindigkeitsverstärkung 110
Redundant encoder 76
Reference cam 159
Reference cam, zero pulse and negative limit switch 157

Reference limitation LIMIT (14) 200
Reference reached REF(6) 199
Reference table 173
Resolver cables 46
Restart 78
RunTimeError 217

S

Saturation characteristic 93
Scaling 113, 174
Scaling / Units 132
Scan cycle SSI information 62
Schematic of expanded torque control 92
Selecting inputs and outputs 191
Selection of modules 241
Sense 49
Sensorless quick-stop 111
SERCOS 238
Settings for the analog input 201
shutdown 146
Simulation 63

SinCo 51

SinCos encoder 46

SinCos module 52

SM voltage controller field-weakening 121

Software limit switch 213

Speed 174

Speed control 78

Speed control in IP mode 183

Speed control in PG mode 182

Speed limitation 211

Speed weighting 135

Speedr 165

SSI 59

SSI encoder simulation 60

SSI features 59

State machine 179

State machine schematic 180

States display 179

Status and control word 171

Status word 233

STO 194

Stop ramps 144

Stop ramps in torque control 145

Switching frequency 23

Switching frequency setting 23

Switching with motor contactor 200

Synchronization 62

Synchronization mode 169

Synchronized movement 163

Synchronous machine field-weakening 118

T

Table of contents 4

Technical data 57, 70

Technology option X8 240

Temperature sensors 38

Terminal assignment 44

Test signal generator (TG) 100

Testing the STO function 195

third-party motor 28

Torque control with defined bandwidth 96

Torque factor 163
Torque limitation 210
Torque weighting 204
Touchprobe 180
Track signal correction 45, 50, 56
Track signal correction (GPOC) 45, 50, 56
transfer function 91, 106
TTL 63
TTL encoder 70
TTL encoder simulation 63
TTL encoder simulation / TTL master encoder 52
TTL encoder zero pulse test 70
TTL signal evaluation 57
TTL signal types 74

U

User-defined scaling 137

V

V/f mode 125
Valid versions 52

Velocity factor 163
Virtual inputs 208
Virtual Master 172
Voltage ratio settings 23
Voltage supply to external encoder 64

W

Warning status window 235
Warning thresholds 233
Warnings 235
Weighting of position data 136
Weighting via the SERCOS profile 133
Wire break 111
Wire break monitoring 202
With zero pulse 160

X

X6 44
X6 Pin assignment 44
X7 51
X7 Pin assignment 48

Z

Zero pulse 58

Zero pulse test 58, 75, 83



LTi DRIVES GmbH
Gewerbestraße 5-9
35633 Lahnau
Germany
Fon +49 (0) 6441/96 6-0

www.lt-i.com
info@lt-i.com

Technische Änderungen vorbehalten.

Die Inhalte unserer Dokumentation wurden mit größter Sorgfalt zusammengestellt und entsprechen unserem derzeitigen Informationsstand.

Dennoch weisen wir darauf hin, dass die Aktualisierung dieses Dokuments nicht immer zeitgleich mit der technischen Weiterentwicklung unserer Produkte durchgeführt werden kann.

Informationen und Spezifikationen können jederzeit geändert werden. Bitte informieren Sie sich über die aktuelle Version unter

www.lt-i.com

ID-Nr.: 0842.26B.1-00 DE

Stand: Januar 2013