

Servomotoren

Bestellkatalog

Baureihe ASM
Asynchronservomotor

Nennmoment von
23 bis 70 Nm

Servomotors

Order Catalogue

Series ASM
asynchronous servomotors

Rated torque from
23 to 70 Nm



 G-line DRIVES

LUST

Kapitel 1: deutsche Version

Chapter 1: German version

Kapitel 2: englische Version

Chapter 2: English version

Bestellkatalog ASM-Servomotoren

Order Catalogue ASM Servomotors

Id.-Nr.: 0814.04 B.1-00

Stand: Oktober 2004

ID No.: 0814.04 B.1-00

Date October 2004

Technische Änderungen vorbehalten.

We reserve the right to make technical changes.

Synchron- oder Asynchronmotor?

Die richtige Motorauswahl

Konstruktiv unterscheiden sich die Servomotoren in erster Linie durch das Aufbauprinzip des Läufers:

- Kurzschlußkäfig-Läufer bei Asynchronservomotoren (ASM)
- Dauermagnet-Läufer bei Synchronservomotoren (LSH)

Ob nun der Synchron- oder doch der Asynchronmotor besser geeignet ist, entscheidet Ihre Anwendung.

Erlaubt Ihre Anwendung ein etwas größeres Bauvolumen, ist im allgemeinen der Asynchronmotor die wirtschaftlichste Lösung; zusätzlich besteht der ASM-Motor durch sehr hohe Maximaldrehzahlen bei konstanter Maximalleistungsabgabe.

Ist jedoch eine extrem kleine Baugröße bei hoher Leistungsdichte gefragt, oder ist für hohe dynamische Ansprüche ein niedriges Rotor-Trägheits-Moment gefordert, dann ist der permanentmagneterregte Synchronservomotor der Baureihe LSH der richtige für Ihre Anwendung.

Eigenschaften der Servomotoren

Die Synchron- und Asynchronservomotoren sind optimal auf die c-line Servoregler abgestimmt. Sie besitzen eine hohe Leistungsdichte und sind auf lange Lebensdauer ausgelegt. Geringe Rastmomente sorgen für exzellente Rundlaufeigenschaften.

Synchron-Servomotoren Baureihe LSH:

- hochenergetische Neodym-Eisen-Bor-Magnete
- geringe Rotorträgheitsmomente
- hohe Leistungsdichte
- exzellente Dynamik
- integrierter PTC
- Resolver
- Schwingstärkestufe R nach DIN ISO 2373 (optional Schwingstärkestufe S möglich)



Nähere Informationen finden sie im Bestellkatalog LSH-Motoren.

Asynchronservomotoren Baureihe ASM:

- robuster Käfigläufer
- Feldschwäcbereich bis 8000 1/min. mit konstanter Leistung
- Welle mit Paßfeder
- integrierter PTC
- Klemmkasten
- Schwingstärkestufe N nach DIN ISO 2373 (optional Schwingstärkestufe R möglich)
- sehr gutes Preis-/ Leistungsverhältnis



Grundausrüstung der ASM-Servomotoren

Merkmal	ASM
Maschinenart	Asynchronservomotor Baureihe ASM
Bauform (DIN 42948)	IM B35, IM B5, V1, V3
Schutzart (DIN 40050)	IP65, Wellendichtung IP64 (Option IP65)
Isolierstoff-Klasse	Isolierstoff-Klasse F nach VDE0530 Wicklungsüber Temperatur $\Delta t = 100^\circ\text{C}$, Umgebungstemperatur $t_u = +40^\circ\text{C}$
Kühlung	Selbstkühlung (IC 0041) IP65
Anstrich	RAL 9005 (matt schwarz)
Wellenende auf A (D) Seite	Paßfeder und Paßfedernut DIN 6885, Toleranzfeld k6
Flanschabmessung	DIN 42948 und IEC 72
Rundlaufgenauigkeit, Koaxialität und Planlauf nach DIN 42955	Toleranz N (normal), R (reduziert) auf Anfrage
Schwingstärke nach ISO 2373	Stufe R, als Option S
Thermische Motorüberwachung	Kaltleiter PTC in der Ständerwicklung

Um eine thermische Überlastung des Motors auszuschließen, darf das effektive Belastungsmoment bei mittlerer Drehzahl nicht oberhalb der S1-Kennlinie liegen.

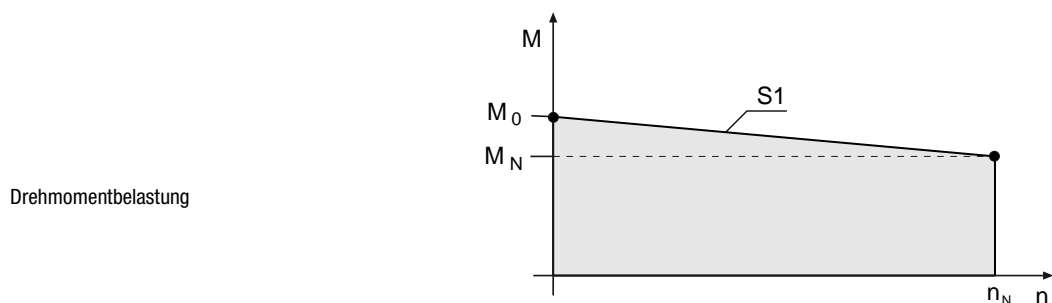

$$M_{eff} = \sqrt{\frac{\sum(M_n^2 \times t_n)}{t_{ges}}} \quad \bar{n} = \frac{\sum(n_n \cdot t_n)}{t_{ges}}$$

Maximales Impulsdrehmoment	Typisch 2- bis 5faches Nennmoment, je nach Reglerzuordnung. Das 3- bis 5fache Nennmoment ist max. für 0,2 s zulässig.
Anschlußart von Motor, Kaltleiter und Haltebremse	Anschluß über Klemmkasten
Anschlußart des Gebersystems	Signalstecker (Gegenstecker nicht im Lieferumfang)

Bestellschlüssel Asynchronservomotoren ASM

Bestellschlüssel Asynchronservomotoren ASM		AS	M	3	4	-	2	0	R2	1	-	0
Asynchronservomotor												
Motortyp												
Bauform Flansch, Selbstkühlung Bauform Flansch, Fremdkühlung Bauform Flansch und Fuß, Selbstkühlung Bauform Flansch und Fuß, Fremdkühlung												
Bauform / Kühlart												
Flansch 110 x 110 mm Flansch 140 x 140 mm Flansch 190 x 190 mm Flansch 260 x 260 mm												
Baugröße Flansch												
Baulänge 1 Baulänge 2 Baulänge 3 Baulänge 4 Baulänge 5												
Baulänge												
3 x 190 V 3 x 330 V 3 x 480 V												
Anschlußspannung												
mit Haltebremse permanent erregt ohne Haltebremse												
Haltebremse												
Resolver 4-polig ECN 1313 ohne Geber												
Drehgebersystem												
1500 1/min 2000 1/min 3000 1/min												
Bemessungsdrehzahl												
Leistungsanschluß Klemmkasten, Drehgeber gerade steckbar												
Anschlußtechnik												
rot = Vorzugstyp												

Motor-Baugrößen	ASM33	ASM34	ASM41	ASM42	ASM43
Stilstands- moment	27,5 Nm	42 Nm	47 Nm	70 Nm	85 Nm
Nennmoment	23 Nm	35 Nm	40 Nm	60 Nm	70 Nm
Netzspannung	3 x 400 V				
Einbaufenster	190 mm		260 mm		

Typische Momentenkennlinie der ASM-Servomotoren

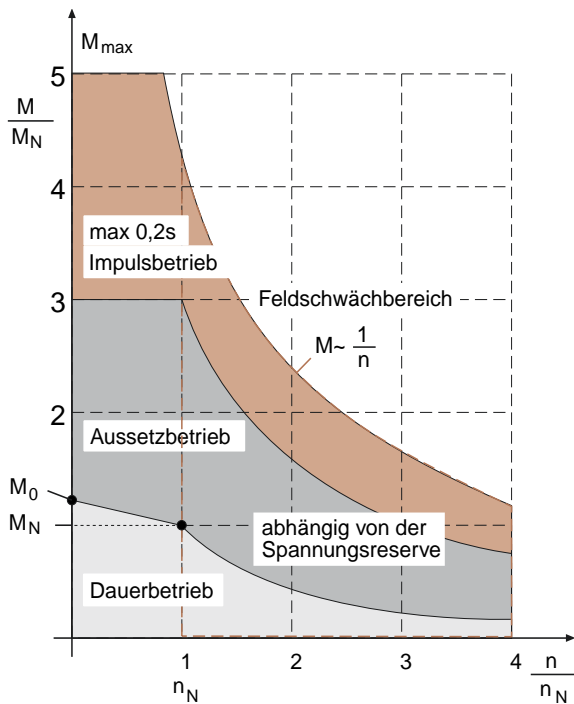

Begriff	Erklärung
M_0 Stillstandsmoment	Thermisches Grenzdrehmoment des Motors bei Stillstand. Dieses Moment kann der Motor über unbegrenzte Dauer abgeben.
I_0 Stillstandsstrom	Effektivwert des Motorstromes, der benötigt wird, um das Stillstandsmoment zu erzeugen.
M_N Nenndrehmoment	Thermisches Grenzdrehmoment des Motors bei Nenndrehzahl n_N .
I_N Nennstrom	Effektivwert des Motorstromes, der benötigt wird, um das Nenndrehmoment zu erzeugen.
P_N Nennleistung	Dauerleistung des Motors am Nennarbeitspunkt (M_N, n_N) bei Nennstrom I_N und Nennspannung U_N .
M_{max}, I_{max} Grenzkennlinie	Die Motoren dürfen max. mit dem 5fachen des Nennstromes beaufschlagt werden.
Feldschwächbereich	Die max. Spitzenmomentabgabe im Feldschwächbereich ist von der Spannungsreserve abhängig. Der typische Verlauf des Drehmoments ist proportional der Funktion $1/f$ bzw. $1/n$.

Kühlung

Die angegebenen Nenndaten beziehen sich auf eine max. Umgebungstemperatur von 40°C und Anbau des Motors an eine Aluminiumplatte mit einer max. Temperatur von 40°C und einer Aufstellhöhe von max. 1000 m ü.NN.

Minimale Befestigungsfläche:
2,5 x Fläche des Motorflansches







Dicke der Befestigungsfläche:
mind. 10 mm

Wenn der Motor isoliert montiert wird (keine Wärmeabgabe über den Flansch), muß eine Reduzierung des Nennmomentes vorgenommen werden.

Ab einer Aufstellhöhe > 1000 m ü.NN muß eine Leistungsreduzierung von 1 % pro 100 m vorgenommen werden. Die maximale Aufstellhöhe beträgt 4000 m.

Bei Umgebungstemperaturen > 40°C muß eine Leistungsreduzierung von 1 % pro 1°C vorgenommen werden. Die maximale Umgebungstemperatur beträgt 50°C.

Auswahlliste Vorzugstyp Servomotor - Servoregler

Einbaufenster [mm]	Motortyp	Stillstands- moment M_0 [Nm]	Nenn- moment M_N [Nm]	Nenn- drehzahl n_N [1/min]	Servoregler ¹⁾		Ü ²⁾
						Nenn- strom	
 190 x 190	ASM33-20R21-0	27,5	23,0	1500	CDD/CDE 34.010	10	2,1
 190 x 190	ASM34-20R21-0	42,0	35,0	1500	CDD/CDE 34.014	14	2,0
 260 x 260	ASM41-20R21-0	47,0	40,0	1500	CDD/CDE 34.024	24	2,4
 260 x 260	ASM42-20R21-0	70,0	60,0	1500	CDD/CDE 34.032	32	2,3
 260 x 260	ASM43-20R21-0	85,0	70,0	1500	CDD/CDE 34.032	32	1,9

1) zugeordneter Servoregler bei Auslegung 1:1 (Nennstrom Motor ≤ Nennstrom Servoregler) 2) Ü = Überlastfähigkeit des Systems

Technische Daten ASM-Servomotoren für 400 V

 Bezeichnung	Stillstandsmoment	Nennmoment	Nennleistung	Stillstandsstrom	Nennstrom	Nenn-drehzahl	max. zul. Drehzahl	Trägheitsmoment des Läu-fers	Gesamtlänge	Masse
	M_0 [Nm]	M_N [Nm]	P_N [kW]	I_0 [A]	I_N [A]	n_N [min ⁻¹]	n_{max} [min ⁻¹]	J_L [kgcm ²]	l [mm]	m [kg]
ASM33-20R21-0	27,5	23	3,6	10,3	8,7	1500	8000	130	387	41,5
ASM34-20R21-0	42,0	35	5,5	15,1	12,6	1500	8000	209	482	56,6
ASM41-20R21-0	47,0	40	6,3	21,0*	17,9*	1500	8000	450	408	87
ASM42-20R21-0	70,0	60	9,4	30,0	25,5	1500	8000	740	498	113
ASM43-20R21-0	85,0	70	11,0	37,0	30,4	1500	8000	960	568	135

* $U_N = 310$ V



Weitere Motortypen auf Anfrage.

Anschlußtechnik



Abbildung	Leistungsanschluß	Geberanschluß
	<p>Leistungsanschluß über Klemmkasten</p> <p>Ringösegröße: 1/2 - Thermistorschutz PRC ASM = M6 BR - Haltebremse (Option) PTC/Bremse = M3 U,V,W - Motoranschluß</p> <p>⊖ - Erde</p>	<p>Resolver</p> <p>Kontaktstifte für 12pol. Anschlußdose: \varnothing 1 mm</p> <ul style="list-style-type: none"> 1 - COS+ (S1) 2 - COS- (S3) 3 - SIN+ (S2) 4 - SIN- (S4) 6 - REF+ (R1) 7 - REF- (R2) 11 - PTC+ 12 - PTC- 5,8,9,10 - nicht belegt

Konfektionierte Geberleitungen



	K	RY	- KS	005
Geberleitung				
Konfektionierte Leitung				
Resolverleitung		RY		
Geberleitung SSI (G3, G5)		GS		
Gebersystem				
Kettenschleppfähig			KS	
Ausführung				
Länge 2 m				002
Länge 3 m				003
Länge 5 m				005
Länge 8 m				008
Länge 10 m				010
Länge 15 m				015
Länge 20 m				020
Leitungslänge				

Geberleitung KRY-KS-005

Bestellschlüssel

Technische Daten:

		KRY-KSxxx	KGS-KSxxx
Reglertyp		CDD/CDE3000	
Motoren mit Gebersystem		Resolver	G5 (Singleturn-Geber mit SSI-Schnittstelle)
Kettenschleppfähig		ja	
Mindestbiegeradius:	bei fester Verlegung	-	40 mm
	bei flexiblem Einsatz	90 mm	100 mm
Temperaturbereich:	bei fester Verlegung		-35 ... +80 °C
	bei flexiblem Einsatz	-40 ... +85 °C	-35 ... +80 °C
Kabeldurchmesser ca.		8,8 mm	8,0 mm
Material des Außenmantels		PUR	PUR
Beständigkeit		öl-, hydrolyse- u. mikrobenebeständig (VDE0472)	öl-, hydrolyse- u. mikrobenebeständig (VDE0472)
Zulassungen		UL-Style 20233, 80 °C - 300 V, CSA-C22.2N.210 -M90, 75 °C - 300 V FT1	-

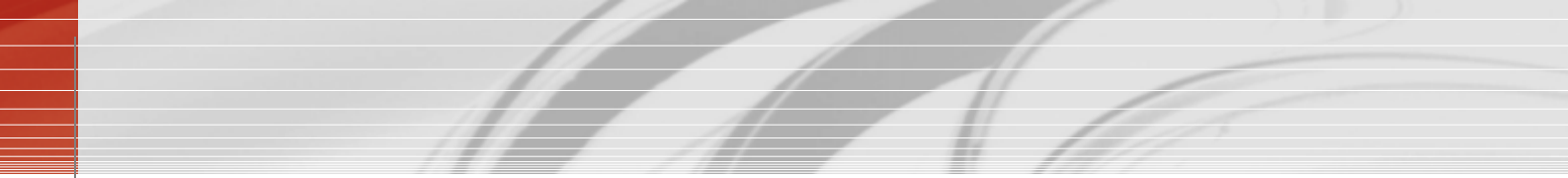

1

Synchronous or asynchronous motor?

Selecting the right motor

The servomotors differ primarily in terms of rotor design:

- Squirrel-cage rotors in asynchronous servomotors (ASM)
- Permanent magnet rotors in synchronous servomotors (LSH)

The question of whether synchronous or asynchronous is more suitable will be determined by your application.

If your application allows a little more space, the asynchronous motor is generally the most cost-effective solution. Another key feature of the ASM motor is its very high maximum speeds at constant maximum output.

If you need very compact design combined with high power density, or a low rotor moment of inertia for high dynamic demands, the permanent-field synchronous servomotor LSH is the right choice for your application.

Servomotor features

The synchronous and asynchronous servomotors are optimally attuned to the c-line servo-controller. They offer high power density and are designed for long life. Low cogging torques ensure outstanding smoothness of running.

LSH series synchronous servomotors:

- High-energy neodymium-iron-boron magnets
- Low rotor moments of inertia
- High power density
- Excellent dynamic properties
- integrated PTC
- Resolver
- Vibration severity grade R to DIN ISO 2373 (optionally grade S possible)



For more information see Order Catalogue LSH Servomotors.

ASM series asynchronous servomotors:

- robust squirrel-cage rotor
- field weakening range to 8000 rpm with constant output
- integrated PTC
- terminal box
- shaft with feather key
- vibration severity grade N to DIN ISO 2373 (optionally grade R possible)
- outstanding value for money



Basic configuration of asynchronous servomotors ASM

Characteristic	ASM
Machine type	Asynchronous servomotor Series ASM
Design (DIN 42948)	IM B35, IM B5, V1, V3
Protection (DIN 40050)	IP65, shaft seal IP64 (option IP65)
Insulating material class	Insulating material class F to VDE0530 Winding overtemperature $\Delta t = 100^\circ\text{C}$, Ambient temperature $t_u = +40^\circ\text{C}$
Cooling	Self-cooling (IC 0041) IP65
Coating	RAL 9005 (mat black)
Shaft end on A (D) side	Featherkey and featherkey way to DIN 6885, tolerance field k6
Flange dimension	DIN 42948 and IEC 72
Smooth-running accuracy, coaxiality and concentricity to DIN 42955	Tolerance N (normal), R (reduced) on request
Vibration severity to ISO 2373	Grade R, option S
Thermal motor monitoring	PTC thermistor in stator winding

In order to avoid a thermal overload of the motor, the effective load torque at medium speed shall not be higher than the S1-characteristic line.

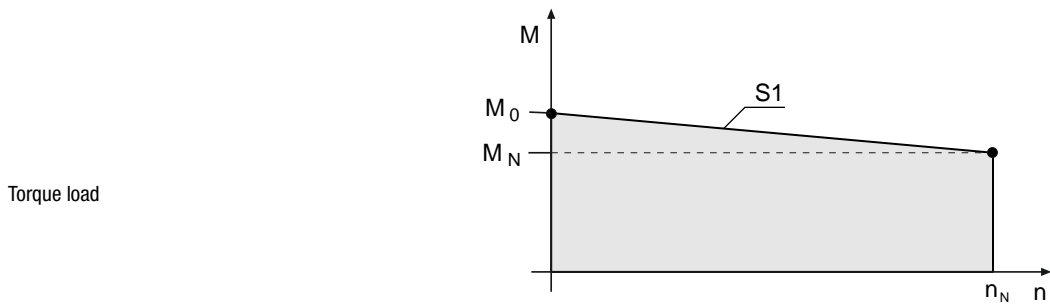

$$M_{eff} = \sqrt{\frac{\sum(M_n^2 \times t_n)}{t_{ges}}} \quad \bar{n} = \frac{\sum(n_n \cdot t_n)}{t_{ges}}$$

Maximum pulse torque	Typically 2 to 5 times nominal torque, depending on controller assignment. 3 to 5 times nominal torque is permissible for max. 0.2 s
Termination mode of motor, thermistor and holding	Termination via terminal box
Termination mode of encoder system	Signal plug (mating plug not supplied)

Order code for asynchronous servomotors ASM

	AS	M	3	4	-	2	0	R2	1	-	0
Asynchronous servomotor											
Motor type											
Design: flange, self-cooling		M									
Design: flange, forced cooling		F									
Design: flange and foot, self-cooling		H									
Design: flange and foot, forced cooling		V									
Design / Cooling type											
Flange 110 x 110 mm			1								
Flange 140 x 140 mm			2								
Flange 190 x 190 mm			3								
Flange 260 x 260 mm			4								
Flange size											
Length 1				1							
Length 2				2							
Length 3				3							
Length 4				4							
Length 5				5							
Length											
3 x 190 V							1				
3 x 330 V							2				
3 x 480 V							4				
System voltage											
with holding brake permanent-field								1			
Without holding brake								0			
Holding brake											
Resolver 4-pole								R2			
ECN 1313								G5			
Without encoder								00			
Encoder system											
1500 rpm									1		
2000 rpm									2		
3000 rpm									3		
Rated speed											
Power connection terminal box, encoder straight plug-in											0
Termination technique											
Red = preferred type											

Motor sizes	ASM33	ASM34	ASM41	ASM42	ASM43
Standstill torque	27,5 Nm	42 Nm	47 Nm	70 Nm	85 Nm
Nominal torque	23 Nm	35 Nm	40 Nm	60 Nm	70 Nm
Mains voltage	3 x 400 V				
Fitting window	190 mm		260 mm		

Typical torque characteristic of asynchronous servomotors ASM

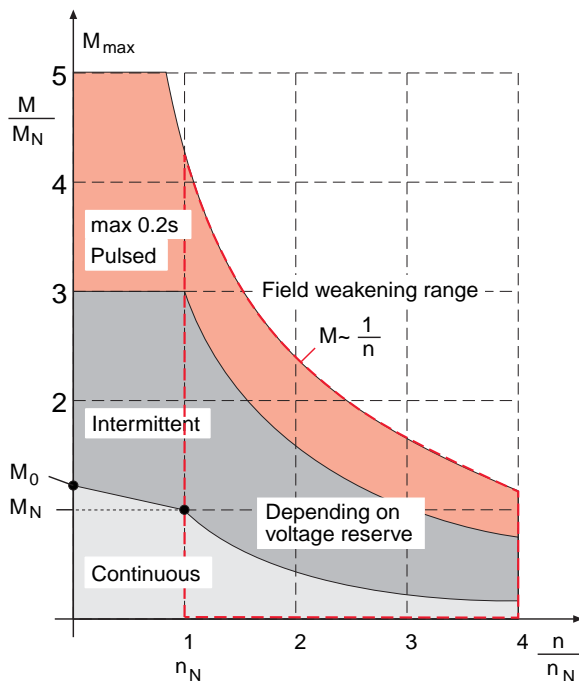

Term	Explanation
M_0 Standstill torque	Thermal limit torque of the motor at standstill. The motor can deliver this torque for an unlimited length of time.
I_0 Standstill current	Effective value of the motor phase current required to generate the standstill torque.
M_N Rated torque	Thermal limit torque of the motor at rated speed n_N .
I_N Rated current	Effective value of the motor phase current required to generate the nominal torque.
P_N Rated power	Continuous power output of the motor at the nominal operation point (M_N, n_N) at rated current I_N and rated voltage U_N .
M_{max}, I_{max} Limit characteristic	A maximum of five times the rated current may be applied to the motors.
Field weakening range	The maximum peak torque output in the field weakening range depends on the voltage reserve. The typical torque characteristic is proportional to the function $1/f$ or $1/n$ respectively.

Cooling

The specified nominal data relate to a max. ambient temperature of 40 °C and mounting of the motor on an aluminium plate with a max. temperature of 40 °C and installed at an altitude of max. 1000 m above MSL.







Minimum mounting area:
2.5 x area of motor flange

Thickness of mounting area:
min. 10 mm

If the motor is mounted with insulation (no heat discharge via the flange) the nominal torque must be reduced.

For installations above an altitude of > 1000 m above MSL the power output must be reduced by 1 % per 100 metres. The maximum installation altitude is 4000 metres. At ambient temperatures > 40 °C the power output must be reduced by 1 % per 1 °C. The maximum ambient temperature is 50 °C.

Selection list for preferred servomotor - servocontroller

Fitting window [mm]	Motor type	Standstill torque M_0 [Nm]	Rated torque M_N [Nm]	Rated speed n_N [rpm]	Servo-controller ¹⁾ 	Rated current	O ²⁾
 190 x 190	ASM33-20R21-0	27,5	23,0	1500	CDD/CDE 34.010	10	2,1
 190 x 190	ASM34-20R21-0	42,0	35,0	1500	CDD/CDE 34.014	14	2,0
 260 x 260	ASM41-20R21-0	47,0	40,0	1500	CDD/CDE 34.024	24	2,4
 260 x 260	ASM42-20R21-0	70,0	60,0	1500	CDD/CDE 34.032	32	2,3
 260 x 260	ASM43-20R21-0	85,0	70,0	1500	CDD/CDE 34.032	32	1,9

1) Assigned servocontroller with rating 1:1 (motor rated current ≤ servocontroller rated current)

2) O = Overload capacity of system

Technical Data asynchronous servomotors ASM for 400 V

 Designation	Standstill torque	Nominal torque	Rated power	Standstill current	Rated current	Nominal speed	Max. perm. speed	Moments of inertia of rotor	Overall length	Mass
	M_0 [Nm]	M_N [Nm]	P_N [kW]	I_0 [A]	I_N [A]	n_N [min ⁻¹]	n_{max} [min ⁻¹]	J_L [kgcm ²]	l [mm]	m [kg]
ASM33-20R21-0	27,5	23	3,6	10,3	8,7	1500	8000	130	387	41,5
ASM34-20R21-0	42,0	35	5,5	15,1	12,6	1500	8000	209	482	56,6
ASM41-20R21-0	47,0	40	6,3	21,0*	17,9*	1500	8000	450	408	87
ASM42-20R21-0	70,0	60	9,4	30,0	25,5	1500	8000	740	498	113
ASM43-20R21-0	85,0	70	11,0	37,0	30,4	1500	8000	960	568	135

* $U_N = 310$ V



Other motor types on request.

Termination technique



Diagram	Power connection	Encoder connection
	<p>Power connection via terminal box</p> <p>Ring size: 1/2 - Thermal protection PTC ASM = M6 BR - Holding brake (option) PTC/Brake = M3 U,V,W - Motor</p> <p>⊖ - Ground</p>	<p>Resolver</p> <p>Contact pins for 12-pole junction box: \varnothing 1 mm</p> <ul style="list-style-type: none"> 1 - COS+ (S1) 2 - COS- (S3) 3 - SIN+ (S2) 4 - SIN- (S4) 6 - REF+ (R1) 7 - REF- (R2) 11 - PTC+ 12 - PTC- 5,8,9,10 - vacant

Ready made-up encoder cables



	K	RY	-	KS	005
Encoder cable					
Ready made-up cable					
Resolver		RY			
Encoder cable SSI or ECN1313		GS			
Encoder system					
Festoon-compatible				KS	
Version					
Length 2 m					002
Length 3 m					003
Length 5 m					005
Length 8 m					008
Length 10 m					010
Length 15 m					015
Length 20 m					020
Cable length					

Encoder cable KRY-KS-005

Technical Data:

	KRY-KSxxx	KGS-KSxxx
Servocontroller type	CDD/CDE3000	
Motors with encoder system	Resolver	G5 (single- or multi-turn encoder with SSI interface)
Festoon-compatible	ja	
Minimum bending radius:		
in fixed installation	-	40 mm
in flexible use	90 mm	100 mm
Temperature range:		
in fixed installation		-35 ... +80 °C
in flexible use	-40 ... +85 °C	-35 ... +80 °C
Cable diameter approx.	8.8 mm	8.0 mm
Material of outer sheath	PUR	PUR
Resistance	Resistant to oil, hydrolysis and microbic attack (VDE0472)	Resistant to oil, hydrolysis and microbic attack (VDE0472)
Approvals	UL-Style 20233, 80 °C - 300 V, CSA-C22.2N.210 -M90, 75 °C - 300 V FT1	-

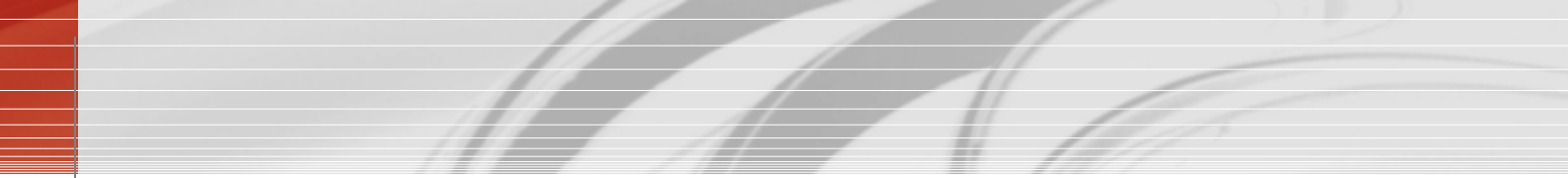

1



Alles für Ihren Erfolg

Everything for your success



www.lust-tec.de
Servo- und Umrichtertriebssysteme
für die Automation

www.lust-tec.de
Servo and inverter drive systems for
automation



www.lust-drivetrronics.de
Servoantriebssysteme für die
Automation

www.lust-drivetrronics.de
Servo drive systems for
automation



www.levitec.com
Motor- und Magnetlagerkomponenten für
hohtourige Antriebe

www.levitec.com
Motor and magnetic bearing components
for high-speed drives



www.sensitec.com
Magneto-resistive sensor-Chips und
Mikrosysteme für die Messung
physikalischer Größen

www.sensitec.com
Magneto-resistive sensor chips
and microsystems for measuring
physical variables



www.naomi-mainz.de
State-of-the-Art Chip-Großserienproduktion
für AMR- und GMR-Sensoren

www.naomi-mainz.de
State-of-the-art large-scale
chip production for AMR
and GMR sensors



www.lust-hybrid.de
Aufbau- und Verbindungstechnik für
Mikrosysteme

www.lust-hybrid.de
Assembly and interconnection
technology for microsystems



Lust Antriebstechnik GmbH

Gewerbestr. 5-9
D-35633 Lahnau
Tel. 0 64 41 / 9 66-0
Fax 0 64 41 / 9 66-137
info@lust-tec.de
www.lust-tec.de



Lust DriveTronics GmbH

Hansastraße 120
D-59425 Unna
Tel. 0 23 03 / 77 9-0
Fax 0 23 03 / 77 9-3 97
info@lust-drivetrronics.de
www.lust-drivetrronics.de

Technische Änderungen vorbehalten. 

We reserve the right to make technical changes.